

innovation in irrigation™

NELSON

SR100 BIG GUN®

SR100 BIG GUN® OPERATION AND MAINTENANCE INSTRUCTIONS

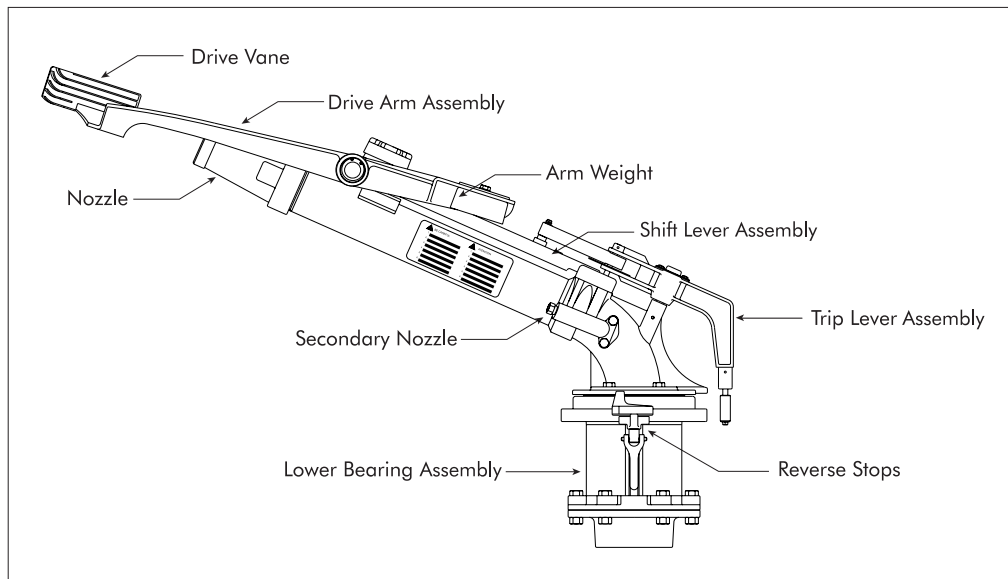

SET UP FOR OPERATION:

1. Install nozzle. If using ring nozzle set, install desired ring size in ring nozzle cap. The ring nozzle cap can be sufficiently tightened by hand.

If using the **100 DN** ring nozzle, **correct orientation** is important. For reliable sprinkler operation, be sure to orient the ring with the correct side out and the "up" at the top of the nozzle. Incorrect orientation can result in failure of sprinkler to drive.

2. Adjust location of reverse stops to give desired arc of coverage. Stops must be mounted so that arrows point toward each other and the trip lever is located between arrows. If the stops are set incorrectly on the wrong end of the arc, the sprinkler will fail to reverse.
3. The SR100 is factory set for normal rotation speed. If a faster or slower speed is desired, move arm weight backward for faster operation or forward for slower operation.

NOTE ON LUBRICATION: The Big Gun® sprinkler is lifetime lubricated and does not require periodic lubrication. The ball bearings in the H.D. lower bearing operate in a water resistant lubricant that is packed in the housing cavities and retained by seals. If repair of the lower bearing is done, it is recommended to use Nelson #6143 lubricant or a good grade of water resistant lubricant such as Lubriplate 130-AA.

BE CAREFUL: Read operating instructions before operating sprinkler or making any adjustments. Never make adjustments or perform service while sprinkler is in operation. Stand clear of operating sprinkler. Stand clear of high velocity water stream. Never direct water stream onto roadway or electrical transmission lines.

WARRANTY AND DISCLAIMER

Nelson Big Gun® Sprinklers are warranted for one year from date of original sale to be free of defective materials and workmanship when used within the working specifications for which the product was designed and under normal use and service. The manufacturer assumes no responsibility for installation, is limited solely to replacement or repair of defective parts, and the manufacturer will not be liable for any crop or other consequential damages resulting from any defects or breach of warranty. THIS WARRANTY IS EXPRESSLY IN LIEU OF ALL OTHER WARRANTIES, EXPRESS OR IMPLIED, INCLUDING THE WARRANTIES OF MERCHANTABILITY AND FITNESS FOR PARTICULAR PURPOSES AND OF ALL OTHER OBLIGATIONS OR LIABILITIES OF MANUFACTURER. No agent, employee or representative of the manufacturer has authority to waive, alter or add to the provision of the warranty, nor to make any representations or warranty not contained herein.

SEE SR100 PARTS LISTS FOR COMPLETE PARTS LIST AND DESCRIPTION

DISASSEMBLY

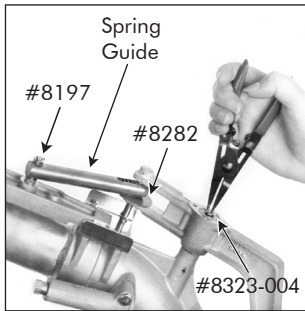

STEP 1 (Trip Lever)

Remove #6714 Cotter Pin from #8197 Pin. Remove two #8311 Screws and #8263 Cap. Using small retaining ring pliers, remove #8323-004 Retaining Ring. Pull entire trip lever assembly and spring guide from gun. At this time inspect wear on #8282 Follower. Replace if worn.

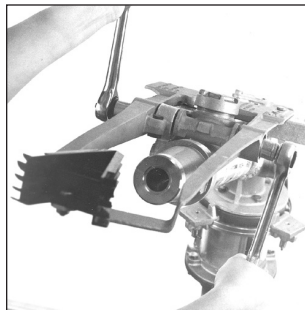

STEP 2 (Drive Arm)

Using internal retaining ring pliers, remove #6565 Retaining Ring from both arm hubs. Remove two #10067-001 Arm Caps. Using two 11/16" sockets, loosen and remove one #6603 Nut from left side of arm. Holding the opposite #6603 Nut, pull shaft free from hub.

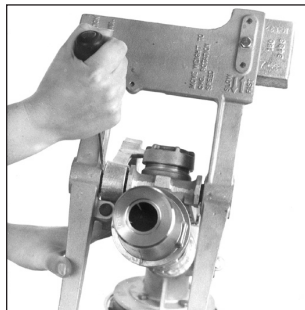

STEP 3

Using a thin-bladed screwdriver, push #8327-001 Spacer back into arm hub. Holding onto counterweight, remove drive arm and counterweight. Be careful not to damage seals.



STEP 4 (Counterweight)

Inspect seal spacer and counterweight spacer for wear. If spacers show excessive wear, replace both spacers and #6600 Seals. To remove seals, drive thin-bladed screwdriver under lip of seal and pry seal out. To replace seals, use block of wood over seal making sure lip is to the outside, and secure by lightly tapping on wooden block until seal lip is flush with hub. Apply a light coating of #9673 Silicone Grease to #6600 Seal Lips.



STEP 5 (Shift Lever)

Remove #10070-001 Cap Assembly. Using external retaining ring pliers, remove #8323-017 Retaining Ring. Pull Shift lever from mount. A gear puller will help in removing the lever. Inspect all parts for wear and replace as required.

REASSEMBLY



STEP 6

At the upper portion of the gun, inspect the mount shaft for wear. Press the #8325 Shift Lever assembly onto the mount. With external retaining ring pliers, snap the #8323-017 Retaining Ring on. Screw on #10070-001 Cap Assembly.

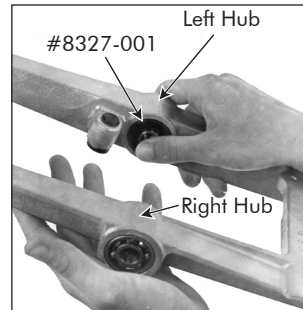

STEP 7 (Drive Arm)

Lubricate #6600 Seal lips with #9673 Silicone Grease. Install #8327-001 Spacer flush with #6600 Seal in left arm hub. Insert two #6607-001 conical Spacers into seals on inside of counterweight and right drive arm hub. Start #8297 Shaft into right arm hub.

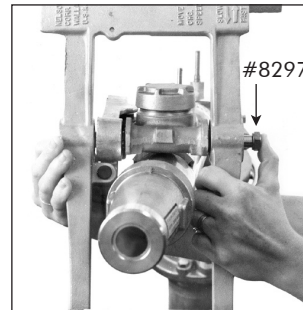

STEP 8

Holding counterweight in place on the left side of shift lever, roll drive arm into position shown by pushing on the left arm bearing. Work #8327-001 Spacer into seal on counterweight. Be sure spacer is correctly positioned in counterweight to prevent cutting of the seal lip. Push shaft through the bearings and spacers and assemble #6603 Nut. Torque to 25 ft. lbs. using two 11/16" sockets. (Metric Torque = 34 NM or 3.5 MKG.)

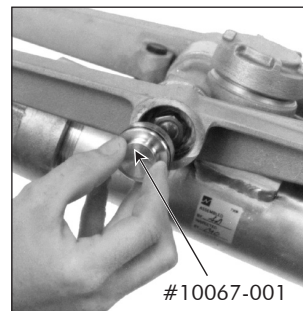

STEP 9

Fill two #10067-001 Arm Cap Assemblies with #6143 Grease and snap into place. Install two #6565 Retaining Rings. Arm must have free movement at this point. If arm feels sticky, assure that lip seals at counterweight and right arm hub are not rubbing on each other.



STEP 10 (Trip Lever)

Mount trip lever assembly along with spring guide onto their respective pins. Install #8323-004 Retaining Ring. Install #8263 Cap using two #8311 Screws. Install #8409 Washer and #6714 Cotter Pin onto spring guide.

SEE BACK PAGE FOR PARTS LIST

DISASSEMBLY (LOWER UNIT)

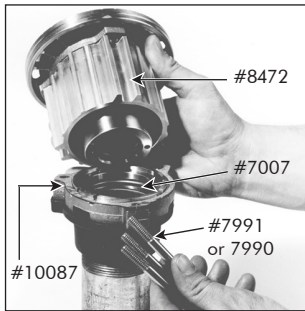

STEP 11
 Remove three #7990 or #7991 bolts from flange. Separate #8472 housing from #10087 Spacer Assembly. Remove #7007 O-Ring from #10087 Spacer Assembly.

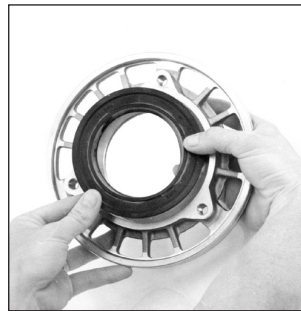

STEP 16
 Place #6997 Lip Seal into #6858 cover as shown with Nelson name toward ball bearing. Pack #6559 Bearing with #6143 lubricant or equivalent. (See "Notes on Lubrication" on the front cover.) Press bearing into #6858 Cover. Slide cover assembly onto bearing shaft. **CAUTION:** Do not get grease on brake surfaces. To clean plastic brake, use soap and water (solvents may damage plastic). Clean #6858 cover with acetone.

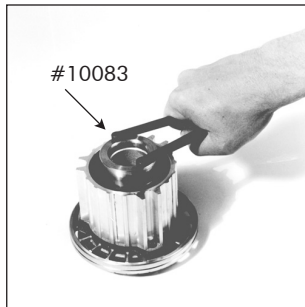

STEP 12
 The #10083 Retainer Assembly is removed by using spanner wrench. To hold the #7031 Shaft Assembly from rotating insert two 5/16-18 bolts (#6635) into shaft top. Clamp bolt heads into a vise securely. Remove retainer and #8472 Housing from bearing shaft.

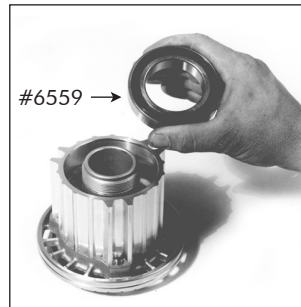

STEP 17
 Assemble #6566 Gasket. Press on #8472 Housing. Fully pack housing with #6143 Lubricant. Assemble #6559 Bearing into housing.



STEP 13
 Remove the #6998 Seal. To remove the two #6559 Bearings use a hammer and three blocks of wood. Lightly tap uniformly around inner race of bearing until removed. Bearings are removed from opposite sides of the #8472 Housing.



STEP 18
 Install #6999 O-Ring in #7003 Retainer and assemble retainer on shaft. Using method described in disassembly (Lower Unit) instructions Step 12, secure bearing shaft from rotating. Torque Retainer to 95-110 ft. lbs. Apply a light coating of #9673 Silicone Grease to O.D. of Retainer. Assemble #6998 Lip Seal. Orient with lip side out. Metric Torque = 129-149 NM or 13-15 MKG.

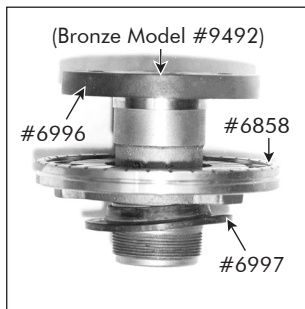

STEP 14
 Remove #6585 Cover from shaft. Remove #6997 Seal from cover. Remove #6996 Brake Ring and #7009 Dust Seal from shaft.

Inspect all parts for wear and replace as required.

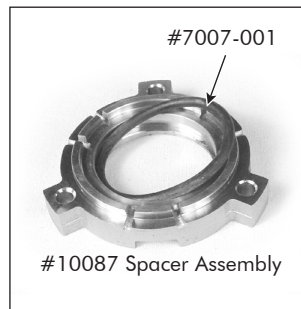

STEP 19
 Install 7007-001 O-Ring into Spacer and mount onto assembly.



REASSEMBLY (LOWER UNIT)

STEP 15
 Assemble #7009 Dust Seal onto #7031 Shaft Assembly. Slide #6996 Brake Ring onto shaft. Locate the four studs of the brake ring in the center holes between the smaller threaded holes.



STEP 20
 Assemble #8967 O-Ring into the Flange Adapter. Mount Flange Adapter using required Bolts. Torque Bolts to 130-150 inch pounds.

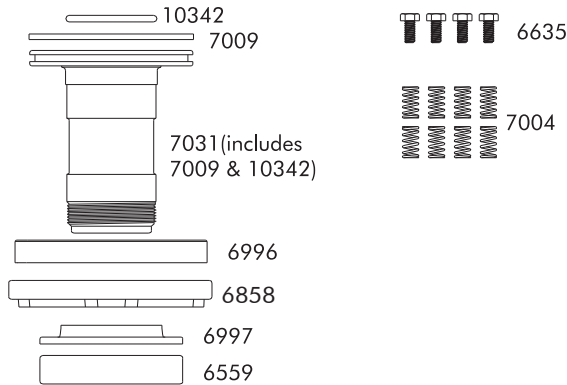

BEARING ASSEMBLY NOS.

7273	2" FNPT
7277	2.5" FNPT
7292	2" FBSP
7753	NELSON FLANGE
9814	ANSI/DIN/EURO FLANGE

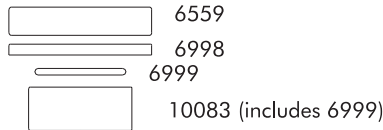
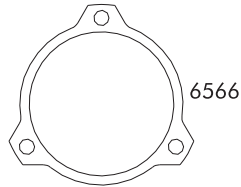
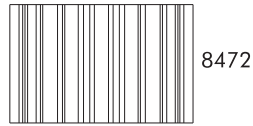

10087 SPACER ASSY 2-PIECE SPACER (2002+)

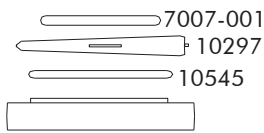

10087-003 SPACER ASSY 1-PIECE SPACER (PRE-2002)

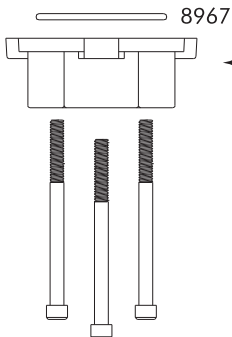
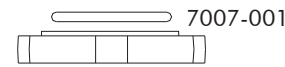

Flg. Assy.**	Connection	(3) Screws
10086	Nelson Flg.	7006
10088-001	2" FNPT	7990
10088-002	2.5" FNPT	7991
10088-003	2" FBSP	7990
10137-001	ANSI/DIN/EURO Flg.	7006

** The Flange Assemblies include O-Ring 8967.

BEARING ASSEMBLY, SR100

part number	description	qty.
6559	Bearing, Ball, 50 x 80 x 16mm	2
6566	Gasket, Housing - HD100	2
6635	Screw, .3125-18 x 688" Hex Hd. Cap	4
6858	Cover, Part Circle - HD100	1
6996	Ring, Brake - HD100	1
6997	Seal, Upper - HD100	1
6998	Seal, Center - HD100	1
6999	O-Ring, -224	1
7004	Spring, Brake - HD100	8
7006	Screw, .3125-18 x 3.50" Hex Skt Hd Cap	3
7007-001	O-Ring, -331, Special, Externally Lubed	1
7009	Seal, Dust - HD100	1
7031	Shaft Assembly - HD100	1
7990	Screw, .3125-18 x 4.25" Hex Hd Cap	3
7991	Screw, .3125-18 x 4" Hex Skt Hd Cap	3
8472	Housing - HD100	1
8967	O-Ring -231, Special	1
10083	Retainer Assembly - HD100	1
10086	Flange Assembly, Nelson	1
10087	Spacer Assy, Alum. - HD100	1
10087-003	Spacer Assy, Brass - HD100	1
10088-001	Flange Assembly, 2" FNPT	1
10088-002	Flange Assembly, 2.5" FNPT	1
10088-003	Flange Assembly, 2" FBSP	1
10137-001	Flange Assembly, 2" ANSI/DIN/EURO	1
10297	Retainer, O-Ring - HD100	1
10342	O-Ring, -225	1
10545	O-Ring, -149	1

MOUNTING HARDWARE

part number	description	qty.
7000	Gasket, Nelson Flange	1
7039	Screw, .3125-18 x .75" Hex Skt Hd Cap	6
10149	Gasket, Euro Flange	1

FLANGE GASKET AND FASTENERS FOR MOUNTING GUN

NELSON FLG. CONN.

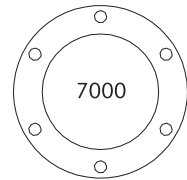

EURO FLG. CONN.

