

800 SERIES CONTROL VALVES

CONTROL VALVE APPLICATION GUIDE

By Tom Young, P.E., M.S.



 **NELSON IRRIGATION CORPORATION**

1.0 TYPES OF CONTROLS ON 800 SERIES VALVES	2
2.0 SELECTING THE RIGHT VALVE	2
2.1 UNDERSTANDING THE CONTROL FUNCTIONS	2
2.1.1 SIMPLE ON/OFF	2
2.1.2 PRESSURE CONTROL VALVES	2
2.1.3 RATE-OF-FLOW CONTROL VALVES	2
2.1.4 COMBINATION VALVES	2
2.1.5 SPECIAL PURPOSE VALVES	2
2.2 TYPICAL VALVE APPLICATIONS	3
2.3 800 SERIES SLEEVE VALVE PARTS TERMINOLOGY	3
2.4 THE ABC'S OF USING THE 800 SERIES VALVE SELECTION GUIDE	5
2.4.1 PRESSURE LIMITS SHOWN IN THE SELECTION GUIDE	5
2.4.2 DESCRIPTION OF FUNCTIONS LISTED IN THE SELECTION GUIDE	6
2.4.3 PRESSURE CONTROL ACCURACY (SENSITIVITY BUSHING)	7
3.0 PROPER VALVE SIZING	7
3.1 SIZING SIMPLE ON/OFF VALVES	7
3.1.1 PRESSURE REQUIRED TO OPEN THE VALVES	7
3.1.2 VALVE PRESSURE LOSS	8
3.2 SIZING PRESSURE CONTROL VALVES	9
4.0 UNDERSTANDING HOW THE PRESSURE CONTROL REGULATOR WORKS	9
4.1 DIFFERENCES BETWEEN 3-WAY AND 2-WAY REGULATORS	9
4.2 HOW THE VALVE RESPONDS TO THE CONTROLS	10
4.3 PRESSURE CONTROL SENSITIVITY AND ADJUSTMENT	11
4.4 FILTRATION OF THE CONTROL CIRCUIT WATER	11
4.5 VALVES USED IN LOW TEMPERATURE	12
5.0 ATTENTION TO THE DANGER OF WATER HAMMER AND SURGE	12
5.1 WATER HAMMER REDUCED BY SMOOTH OPERATION OF THE 800 SERIES	12
5.2 USE AIR VENTS TO PREVENT AIR ACCUMULATION	12
5.3 SOME THINGS WHICH HELP REDUCE THE DANGER OF WATER HAMMER	12
5.4 PRESSURE CYCLE INDUCED BY THE ELASTICITY OF HOSE AND TUBING	13
6.0 ELECTRICAL APPLICATIONS	13
6.1 VALVE WIRING (FROM THE CONTROLLER TO THE VALVE)	13
6.2 METHODS OF WIRE SIZING	13
6.2.1 WIRE SIZING WITH TABLES	13
6.2.2 WIRE SIZING WITH FORMULAS	15
6.3 WHEN YOU NEED TO USE DC POWER	16
SAFETY FIRST	16
APPENDIX A PRESSURE CONTROL REPLACEABLE SENSITIVITY BUSHING	17
APPENDIX B FILTER SELECTION FOR THE 800 SERIES VALVE	18
APPENDIX C FLOW PATHS AND PORTS FOR CONTROL COMPONENTS	19
APPENDIX D SPECIAL FUNCTION LOOKUP TABLE	20
APPENDIX E MATERIALS LIST FOR THE 800 SERIES VALVE	21
APPENDIX F PARTS & DIMENSIONS	22

1.0 TYPES OF CONTROLS ON 800 SERIES VALVES

NELSON 800 Series Control Valves are available in several configurations. Understanding these basic valves puts a designer in a better position to understand all of the combined types, functions and design requirements. Valves are best categorized by operating control function.

These are the operating control functions presently available:

- **Simple ON/OFF Control (manual or automatic) Valves**
- **Pressure Control Valves** (these valves work using a pressure control regulator)
 - Pressure Reducing
 - Pressure Sustaining
 - Pressure Relief
- **Rate-Of-Flow Control Valves** (used to maintain a desired flow rate)
- **Combination Valves**
 - More than one control function. EXAMPLE: pressure reducing with automatic on/off.
- **Special Purpose**
 - Check Valves
 - Sleeve Exhaust
 - Special on/off mode or special function.

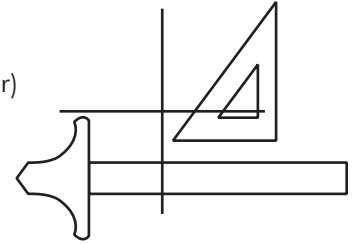

2.0 SELECTING THE RIGHT VALVE

Selecting the right valve for the job consists of understanding, then selecting the proper control function and proper valve sizing. The best sequence is 1) Choose the control function to serve the purpose, 2) Select the valve size and pressure rating, and 3) Verify that the operating range for the selected valve is correct. This document is to be used as a guideline and is not a complete strategy for design.

2.1 UNDERSTANDING THE CONTROL FUNCTIONS

2.1.1 SIMPLE ON/OFF

MANUAL CONTROL: The MANUAL ON/OFF control is used to open or close the valve. The flow through the valve is controlled by a rubber sleeve which is actuated by hydraulic pressure. The valve is either in the fully opened or the closed (shut off) position. The "AUTO" position on the selector has no effect on valve control but is used when the valve is equipped with automatic controls.

AUTOMATIC CONTROL: If the valve is equipped with an electric solenoid, the on/off function can be automatic by using an electric controller. When the selector is pointed to the "AUTO" position then the electric solenoid is used to automatically open or close the valve. The 3-way electric solenoid must be energized to open the valve and de-energized to close the valve. Pointing the manual selector handle to "OPEN" or "CLOSE" will override the "AUTO" control.

2.1.2 PRESSURE CONTROL VALVES

Pressure control valves react or respond through a pressure control regulator. The pressure control regulator directs water flow which positions the sleeve during operation. If the control function is pressure reducing, the sleeve position (or flow through the valve) is controlled by downstream pressure. If the control function is pressure sustaining or relief, the sleeve position is controlled by upstream pressure.

2.1.3 RATE-OF-FLOW CONTROL VALVES

The Rate-Of-Flow control valves operate by a flow sensing probe in the pipe. A calibrated adjustment screw is used to set the desired flow. The flow velocity moves the probe to maintain the desired rate-of-flow.

2.1.4 COMBINATION VALVES

Combining functions of more than one control is possible with the NELSON 800 Series Control Valve. The most common combination is the automatic on/off combined with a reactive pressure control.

2.1.5 SPECIAL PURPOSE VALVES

The check valve feature is used to prevent flow reversal. The check option is available separately or with most on/off and reactive control functions.

The sleeve exhaust is a special valve used to exhaust water from the sleeve chamber and allow fast opening response on the valve. The sleeve exhaust is most often used with turbine well pumps. During start-up a column of water begins moving at high velocity. When the water contacts the valve, quick opening is required to prevent damage.

Special on/off mode valves are used where standard valves don't work due to system requirements. An example of this is the hydraulic remote control which eliminates the need for wires in the field. See section 2.4.2 for more information on the hydraulic remote function. Contact the factory for specific details on the special function valve control. See Appendix D for a quick lookup table.

2.2 TYPICAL VALVE APPLICATIONS

Typical valve applications in agriculture are shown in Figure 2 on the following page labeled TYPICAL CONTROL APPLICATION. The sketch indicates where the different valves could be applied. Not every valve control type is required on most systems. The sketch is for demonstration purposes only.

2.3 800 SERIES SLEEVE VALVE PARTS TERMINOLOGY

It is necessary to know the name of the parts of the basic sleeve valve to understand how the valve functions. The cross section drawing (Figure 1) shows the general parts of the Nelson 800 series valve.

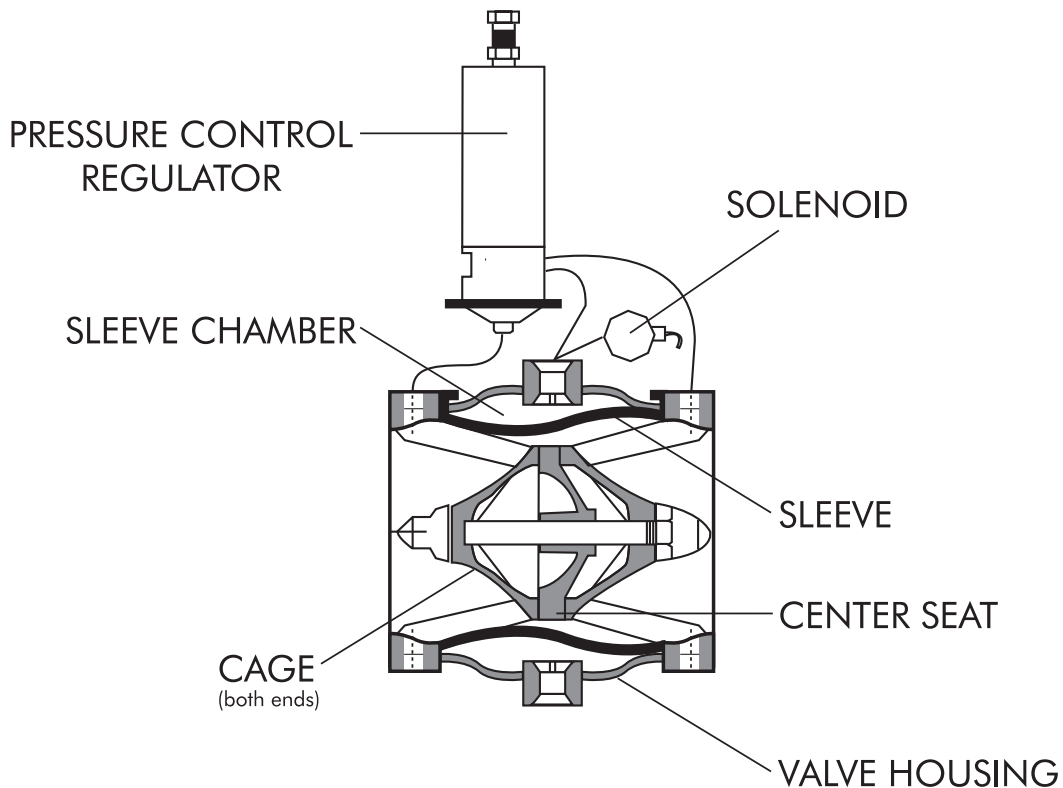

Figure 1

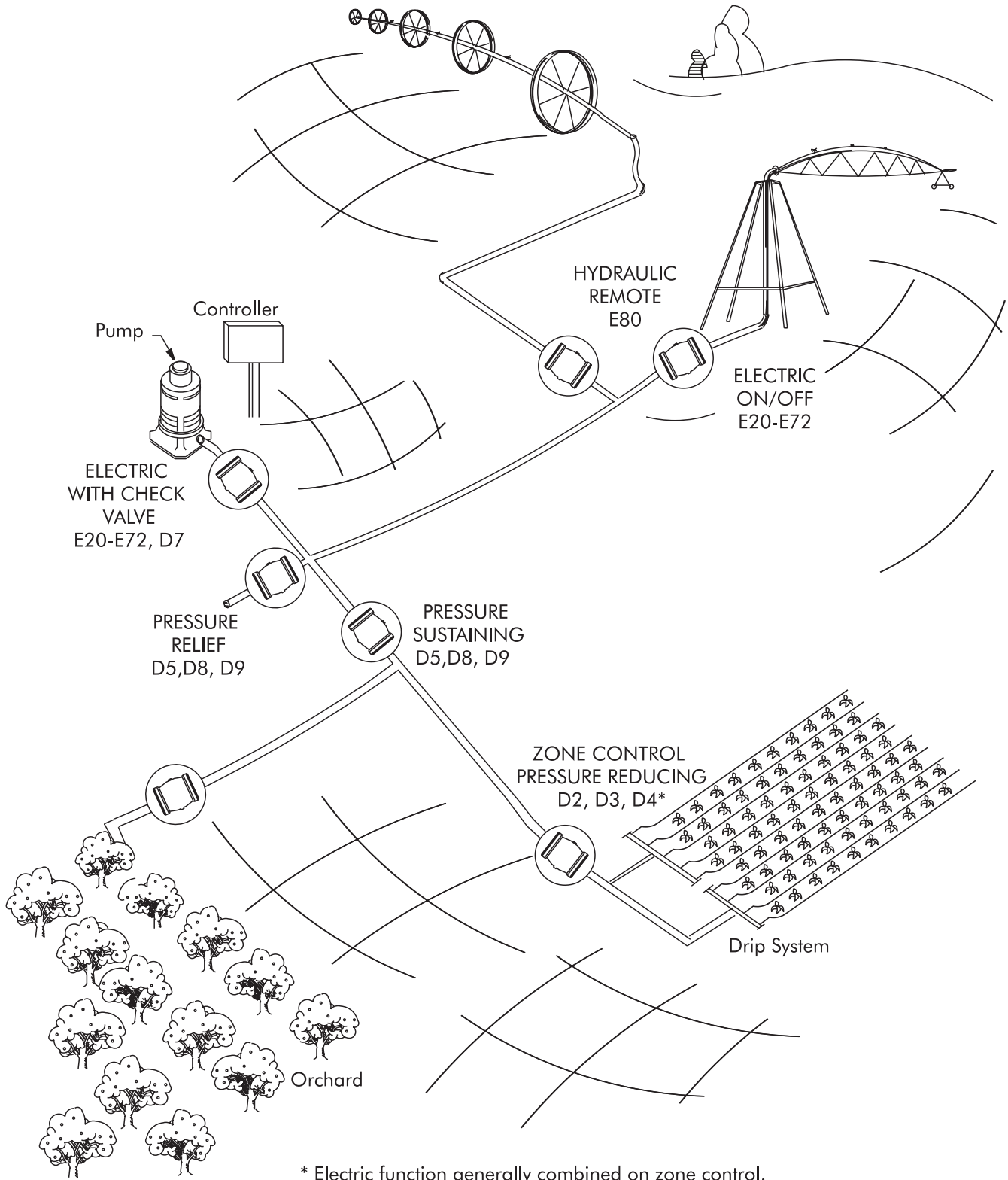

Figure 2

2.4 THE ABC'S OF USING THE 800 SERIES VALVE SELECTION GUIDE

This simple guide will help a designer select the best valve for the job. The VALVE SELECTION GUIDE shown in Figure 3 on this page. Column A, B and C refer to the VALVE. Columns D through H refer to the CONTROL FUNCTION package. All valves are shipped with the manual selector valve. In Column D a combination of control functions can be selected. Assistance is available from the factory for answering questions about the combinations of Column D functions. **NOTE:** If the connection is thread then provide a union or coupling nearby to make it possible to easily remove the valve if necessary!



A		B	C	D		E	H
VALVE SIZE	VALVE CONNECTION STYLE	VALVE OPERATING PRESSURE	CONTROL FUNCTION (PSI in this column indicates range of adjustment.)	ON/OFF MODE	FILTER OPTIONS		
A2"	B3 THREAD	C1 10-50 PSI	D1 MANUAL ON/OFF CTRL.	E1 NO SOLENOID	H1 NONE		
	B4 WAFER WITHOUT BOLTS	C2 30-200 PSI	D6 SLEEVE EXHAUST	E23 9/12VDC LATCHING <small>(Use with Solorain Valve Controllers)</small>	H2 EXTERNAL		
	B5 WAFER WITH BOLTS INCLUDED 2"/3" Valve	C3 18-80 PSI	D7 SHUTTLE CHECK VALVE <small>(Must accompany solenoid or sustaining ctrl.)</small>	E43 24VAC (.13 AMP)	H3 INTERNAL		
	B6 VICTAULIC		D12 REDUCING 5 - 50 PSI	E44 24VAC LDOS <small>(Long Distance Operating Solenoid)</small>			
	B7 WAFER FOR BIG GUN ANSI — WITH BOLTS 2"/3" Valve		D13 REDUCING 10 - 120 PSI	E53 120VAC			
			D15 SUSTAINING 5 - 50 PSI	<div style="border: 1px solid black; padding: 5px;"> <p>2.4.1 PRESSURE LIMITS SHOWN IN THE SELECTION GUIDE The VALVE SELECTION GUIDE shows two pressure ratings. In column 'C' the maximum pressure rating shown is for the valve. In column 'D' the pressure adjustment range shown is for the pressure control pilot function. The lower limit of the range of 'C' is the amount of pressure required to overcome the sleeve resilience to fully open the valve. (See Table 2.) The upper pressure limit of the control function is the limit of the spring enclosed in the pressure control pilot.</p> </div>			
			D16 SUSTAINING 10 - 120				
		D18 RATE OF FLOW					
			D19 SURGE 2-WAY PILOT				
A4"	B4 WAFER WITHOUT BOLTS	C1 10-50 PSI	D1 MANUAL ON/OFF CTRL.	E1 NO SOLENOID	H1 NONE		
	B5 WAFER WITH BOLTS INCLUDED 4"/6"/8" Valve	C2 30-200 PSI	D2 REDUCING 5 - 50 PSI	E20 12-24VDC 1/16" LATCHING <small>(.5 AMP MAX)</small>	H2 EXTERNAL		
	B7 WAFER FOR BIG GUN ANSI — WITH BOLTS 4" Valve	C3 18-80 PSI	D3 REDUCING 10 - 120 PSI	E21 12VDC 1/16" (.6 AMP MAX)	H3 INTERNAL		
			D4 REDUCING 25 - 200 PSI	E24 9/12VDC LATCHING <small>(Use with Solorain Valve Controllers. See Page 14)</small>			
			D5 SUSTAINING 25 - 200 PSI	E30 24VDC 1/16" (.3 AMP MAX)			
			D6 SLEEVE EXHAUST	E40 24VAC 1/16" (.15 AMP Inrush)			
			D7 SHUTTLE CHECK VALVE <small>(Must accompany solenoid or sustaining ctrl.)</small>	E41 24VAC 1/16" (1.1 AMP Inrush) <small>(Heavy Duty)</small>			
			D8 SUSTAINING 10 - 120 PSI	E42 24VAC 1/8" (3.6 AMP)			
			D9 SUSTAINING 5 - 50 PSI	E50 120VAC 1/16" <small>Higher voltage solenoid kits available. Call for details.</small>			
			D18 RATE OF FLOW	E80 Hydraulic Remote Ctrl.			
		D19 SURGE 2-WAY PILOT					

2.4.2 DESCRIPTION OF FUNCTIONS LISTED IN THE SELECTION GUIDE

MANUAL ON-OFF

VALVE CONTROL FUNCTION (items D1, E1 on the VALVE SELECTION GUIDE):

The **MANUAL ON-OFF** model of the 800 Series Control Valve is a hydraulically operated sleeve type valve with a manual control. The **MANUAL ON-OFF** control is used to open or close the valve. The valve is normally either in the fully opened or the closed (shut off) position but pointing the selector handle mid-way between ports can hold the sleeve in a partly open position. The "AUTO" position on the selector has no effect on valve control but is used when the valve is equipped with automatic controls.

ELECTRIC ON-OFF

VALVE CONTROL FUNCTION (items D1, E20 through E72 on the VALVE SELECTION GUIDE):

The **ELECTRIC ON-OFF** model of the 800 Series Control Valve is a hydraulically operated sleeve type valve with an electric solenoid control. The valve is either in the fully opened or the closed (shut off) position. When the selector is pointed to the "AUTO" position then the electric solenoid is used to automatically open or close the valve. The 3-way electric solenoid must be energized to open the valve and de-energized to close the valve. Pointing the manual selector handle to "OPEN" or "CLOSE" will override the "AUTO" control except when the selector is pointed to "OPEN" the pressure reducing control still functions but the solenoid has no effect.

PRESSURE REDUCING MANUAL ON-OFF

VALVE CONTROL FUNCTION (items D2 through D4, E1 on the VALVE SELECTION GUIDE):

The **PRESSURE REDUCING MANUAL ON-OFF** model of the 800 Series Control Valve is a hydraulically operated sleeve type valve with a pressure reducing pressure control kit and a manual on-off. When the selector is pointed to the "AUTO" position then the valve will automatically reduce a higher inlet pressure to a constant lower downstream pressure. The pressure reducing control is adjustable to give a constant down stream pressure even with fluctuating upstream pressure. The manual selector is used to manually open or close the valve. Pointing the manual selector handle to "OPEN" or "CLOSE" will override the "AUTO" control except, when the selector is pointed to "OPEN", a safety plug installed at the factory must first be removed to open the valve.

PRESSURE REDUCING ELECTRIC ON-OFF

VALVE CONTROL FUNCTION (items D2 through D4, E20 through E72, on the VALVE SELECTION GUIDE):

The **PRESSURE REDUCING ELECTRIC ON-OFF** model of the 800 Series Control Valve is a hydraulically operated sleeve type valve with a pressure reducing pressure control kit and an electric solenoid. When the selector is pointed to the "AUTO" position then the valve will automatically reduce a higher inlet pressure to a constant lower downstream pressure. The pressure reducing control is adjustable to give a constant downstream pressure even with fluctuating upstream pressure. The electric solenoid is used to automatically open or close the valve remotely. When in the "AUTO" position the 3-way electric solenoid must be energized for the pressure control to work and de-energized to close the valve. Pointing the manual selector handle to "OPEN" or "CLOSE" will override the "AUTO" control except, when the selector is pointed to "OPEN", the pressure reducing control still functions but the solenoid has no effect.

PRESSURE SUSTAINING/RELIEF

VALVE CONTROL FUNCTION (items D5, D8, D9, with E1 on the VALVE SELECTION GUIDE):

The **PRESSURE SUSTAINING/RELIEF** model of the 800 Series Control Valve is a hydraulically operated sleeve type valve with a pressure sustaining/relief pressure control kit and a manual on-off. When the selector is pointed to the "AUTO" position, then the pressure control kit will automatically sustain the upstream pressure on the valve. If the valve is **installed in-line of the main flow**, it will maintain the desired upstream pressure by controlling the amount of water that is allowed to flow through the valve. If the valve is **installed on a tee or bypass which allows free discharge**, then it will maintain the desired upstream pressure by relieving flow through the discharge tee. The pressure sustaining/relief control is adjustable to sustain or relieve at a desired upstream pressure. The manual selector is used to manually open or close the valve. Pointing the manual selector handle to "OPEN" or "CLOSE" will override the "AUTO" control, a safety plug installed at the factory must first be removed to open the valve. Several variations of this control are available to accomplish the desired result. See Appendix D for a quick lookup table of options.

RATE-OF-FLOW CONTROL

Valve Control Function (items D18 on the VALVE SELECTION GUIDE):

The **RATE-OF-FLOW CONTROL** model of the 800 Series Control Valve is an add on control that maintains a preset flow rate by means of a velocity sensing probe in the pipe. An adjustment screw is used to set the desired flow rate. This control can be combined with most other controls.

SPECIAL ON/OFF MODES

Special on/off modes are available on many of the control functions. For a list of the available modes contact the Nelson factory. Note in Figure 3 the option E80. The hydraulic remote is operated via hydraulic tubing which is run from the controller to the valve instead of electric wire. The electric solenoid is located near the controller. Wires in the field are minimized. This is used in areas which have a high potential for lightning damage to the electric system. A special function S10 can also be used to accomplish the same purpose if infield elevation is minimal (See Appendix D).

2.4.3 PRESSURE CONTROL ACCURACY (SENSITIVITY BUSHING)

The accuracy of the regulating control is a combination of valve friction loss, the slight hysteresis within the regulator and the sensitivity bushing used in the pressure control. The valve friction loss is dependent upon flow rate. It can be determined from the loss plot in Graph 1. The overall accuracy of regulation is shown in Table 1 below.

**Table
1**

CONTROL RANGE SELECTED	ACCURACY OF SENSITIVITY BUSHING OPTION SELECTED		
	RED	BLUE	BLACK
5-50PSI (.3-3.4Bar)	± 1PSI (.07Bar)	± 1.5PSI (.1Bar)	± 2PSI (.13Bar)
10-120PSI (.7-8.3Bar)	± 3PSI (.21Bar)	± 4.5PSI (.31Bar)	± 6PSI (.41Bar)
10-200 PSI (.7-13.8Bar)	± 4PSI (.28Bar)	± 7PSI (.48Bar)	± 9PSI (.62Bar)

For more detail on the sensitivity bushing feature see Section 4.3 and Appendix A.

INSTALLATION HINT: To improve regulator accuracy, avoid installing a pressure tap in a turbulent flow area. An impeller type flow meter immediately upstream may create turbulence that can cause reduced pressure control accuracy. For pressure reducing control, a down stream pressure tap at the end of a 24 inch (60 cm) long straight pipe will help. Also, use of a straight pipe on the upstream end of the valve will help. To be effective the upstream pipe should be a minimum five pipe diameters long.

3.0 PROPER VALVE SIZING

Proper valve sizing is critical in designing control valve systems. The valves must be sized correctly for the reactive control functions to work (reducing or sustaining). A high percentage of control valve problems can be directly traced to the initial selection of the wrong size valve. Be aware of these two common problems:

POTENTIAL PROBLEM #1: The most common error occurs in over-sizing a pressure control valve. The error occurs by ignoring the operation and specifying that the size be the same diameter as the pipe. While this simplifies installation, it may result in the use of a valve that is too large. At lower flow rates this over sizing leads to severe problems such as cavitation, water hammer and pressure cycling.

POTENTIAL PROBLEM #2: Almost as common as the above is selecting the control valve from flow graphs. Such graphs set the limits of minimum and maximum flow rates for each size but the graphs do not account for the pressure drop across the valve. Since both factors, flow rate and pressure drop, combine to determine the sleeve position both must be taken into account for the proper sizing of reactive control valves.

Information in the application guide is to aid in avoiding the common problems.

3.1 SIZING SIMPLE ON/OFF VALVES

To size simple on/off valves a designer must look at the valve pressure rating and then the friction loss. Doing this will assure a valve with adequate pressure rating is used and also that pressure loss through the valve will be allowed for in the design.

3.1.1 PRESSURE REQUIRED TO OPEN THE VALVES

The minimum necessary pressure to open the valves is shown in Table 2, to the right.

Table 2

VALVE RATING	
50 PSI — C1 MODEL	begin opening = 2 PSI fully open = 10 PSI
200 PSI — C2 MODEL	begin opening = 6 PSI fully open = 28 PSI
80 PSI — C3 MODEL	begin opening = 6 PSI fully open = 18 PSI

3.1.2 VALVE PRESSURE LOSS

The reason to consider pressure loss through the valve is to assure adequate pressure will be available to the irrigation system. Pressure loss is defined by the following basic equation:

$$\Delta P = (Q/C_v)^2$$

- P_1 = Pressure on the upstream side of the valve
- P_2 = Pressure on the downstream side of the valve
- ΔP = Pressure loss across the valve in PSI
- Q = Flow through the valve in GPM
- C_v = Valve sizing coefficient (flow rate at which one psi DP occurs.)

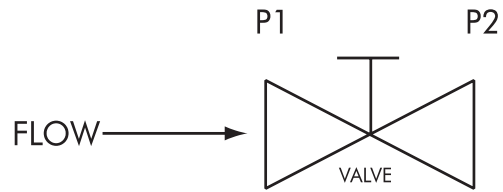

NOTE: C_v provides an index for comparing the capacities of different size valves. The C_v coefficient is defined as the flow (GPM) which will pass through the valve with a pressure loss of 1 PSI (the larger the coefficient the greater the valve capacity).

The C_v for the Nelson 800 Series control valve is:

- 8" size C_v = 2000 GPM
- 6" size C_v = 1100 GPM
- 4" size C_v = 310 GPM
- 3" size C_v = 240 GPM
- 2" size C_v = 115 GPM

The following graph can be used to determine pressure loss for a simple ON/OFF valve. GRAPH 1 applies to a fully open valve. The valves were tested with adequate pressure to be fully open as listed in Table 2. Pressure control valves typically operate in a partially closed condition. See the section 3.2 on sizing other reducing and sustaining valves for more information.

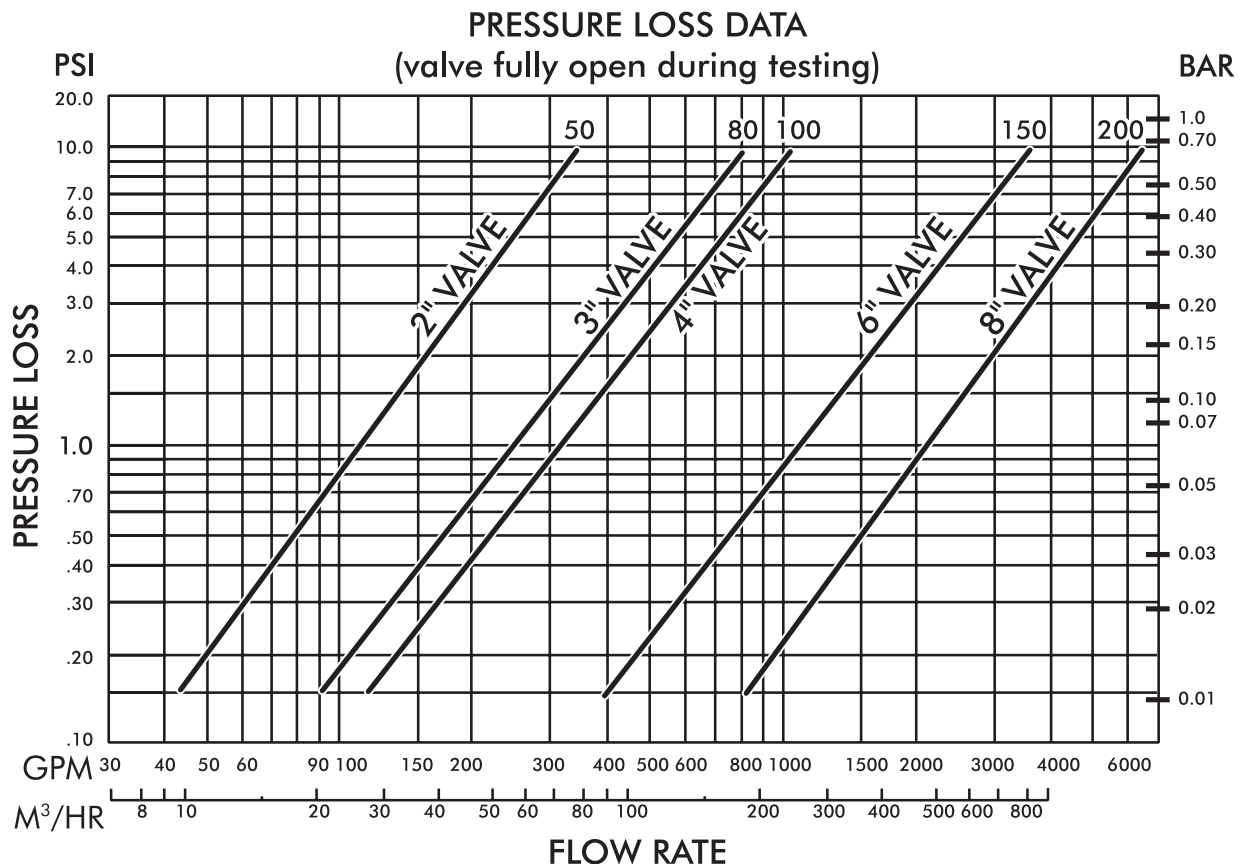

Graph 1

3.2 SIZING PRESSURE CONTROL VALVES

To size pressure control valves, both the pressure loss and the operating conditions must be considered. Generally the pressure control valve is only partially open. The sleeve reacts to the pressure regulator which responds to the changes in the irrigation system pressure. To correctly size the 800 Series valve size, three things must be considered: 1) the pressure differential, 2) the flow through the valve and 3) the expected downstream pressure.

When doing a design, determine the worst case pressure differential operation point. A large pressure differential and a low flow condition will position the sleeve very near the center seat. This condition should be avoided. It is generally best to select the smallest valve which will work.

If cavitation occurs it could cause wear and deterioration of the valve parts. Nelson Irrigation can make no guarantee that the valve will work under all conditions because of the many variables which can be encountered. Ongoing tests are being conducted at this time to exactly identify the areas of operation that are safe. Each valve style has unique performance. Contact the Nelson Irrigation factory for the latest test results and information on the valves.

A NOTE OF CAUTION: Significant fluctuation of pressure can be a problem in some hydraulic systems if a cyclic pressure wave develops. Abrupt pressure change or flow change is a potential cause which could upset the valve. It is also possible that extra long pipe, either upstream or downstream, or valves in series can create a condition where the regulator "hunts" and is not stable. This condition is difficult to predict. Many times the problem can be avoided by using a RATE-OF-FLOW control slowly filling the line or slowly changing flow rate. If the unstable situation is due to pressure control responsiveness, then see Section 4.3 or contact the Nelson factory for assistance regarding the pressure control sensitivity options available which have been designed to solve such problems. Impeller type flowmeters cause turbulence that can affect the valve sleeve. Do not locate flowmeter immediately upstream of the valve. If a flowmeter is to be used then it is best to locate it downstream of the valve.

4.0 UNDERSTANDING HOW THE PRESSURE CONTROL REGULATOR WORKS

The regulator used on the NELSON 800 Series Control Valve is a three-way (3-way) regulator. The regulator adjustment screw is used to establish the pressure set point. If the pressure is higher than the internal spring then water is directed through the regulator to change the sleeve position.

Other two-way (2-way) regulators function differently from the Nelson 3-way regulator. See the discussion on differences in section 4.1. The following page (Section 4.2) shows in Figure 4 how the Nelson 3-way control regulator functions and the resulting affect on the 800 Series valve under different situations.

4.1 DIFFERENCES BETWEEN 3-WAY AND 2-WAY REGULATORS

The 800 Series pressure control is a 3-way, spool-type pilot designed to serve pressure regulating purposes. The pressure control is a self contained regulator with no external accessories needed. It works very well for both pressure reducing and pressure sustaining or relief. While many other manufacturers use 2-way pressure control pilots that depend upon continuous water flow through them, the 3-way pilot on the NELSON 800 Series Control Valve operates by directing very small amounts of water in and out of the sleeve chamber.

The 3-way pilot on the NELSON 800 Series Control Valve has the following benefits:

- **LOWER PRESSURE LOSS:** The 3-way pilot reduces pressure loss across the valve because when turned to open; the valve completely opens.
- **LESS FILTRATION:** Water moves through the controls only when there is a change in line pressure. At steady pressure conditions, there is no water flow through the control pilot.
- **SIMPLE ADJUSTMENT:** Setting of the desired pressure is simple with the Nelson 3-way regulator. Only a single adjusting screw is used and no flow control auxiliary devices are required. See Appendix A for pressure adjustment control instructions. Due to the features of the 3-way pilot, maintenance of the NELSON 800 series pressure control pilot is minimum and many times troubleshooting of the controls is simple and can be done with little training.
- **MORE ACCURATE:** The 3-way pilot on the NELSON 800 Series Control Valve has a pressure control regulator which is extremely reliable and sensitive to slight pressure changes.
- **LESS COMPLICATED:** The Nelson 3-way pilot eliminates the need for flow regulating needle valves reducing maintenance requirements. The 3-way regulator filter may never need cleaning because of the low quantity of water flow required for the control pilot. This helps in the reliability of the entire control package!

4.2 HOW THE VALVE RESPONDS TO THE CONTROLS — Figure 4

SOLENOID CONTROL

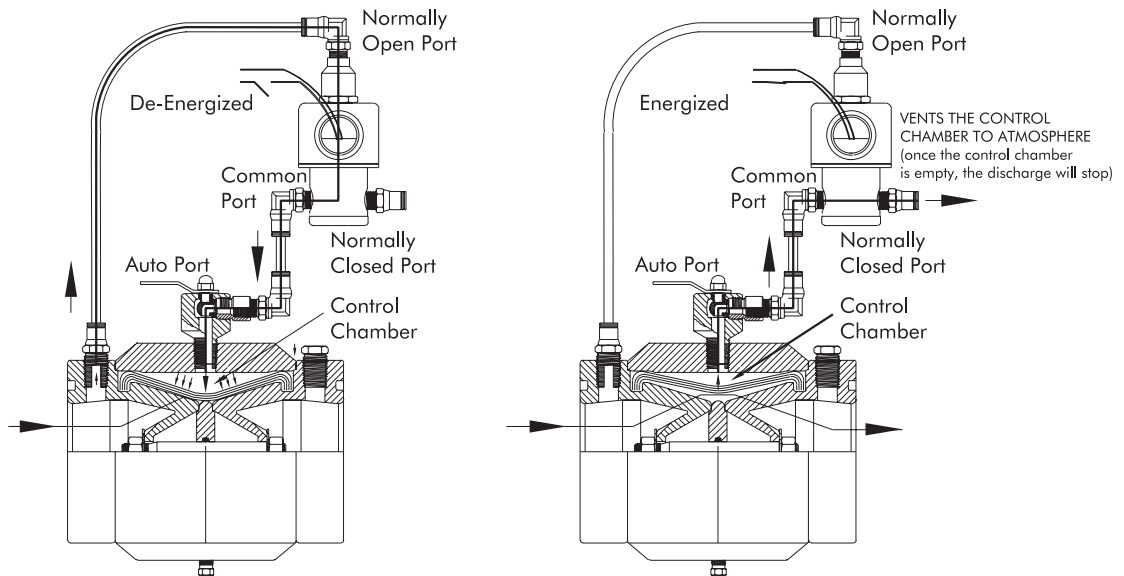

Solenoid de-energized
The upstream water is applied to the sleeve chamber. The flow is closed off by the sleeve against the center seat.

Solenoid energized
The upstream water is blocked. The sleeve chamber is vented to the atmosphere, the flow of the valve is open.

PRESSURE REDUCING CONTROL

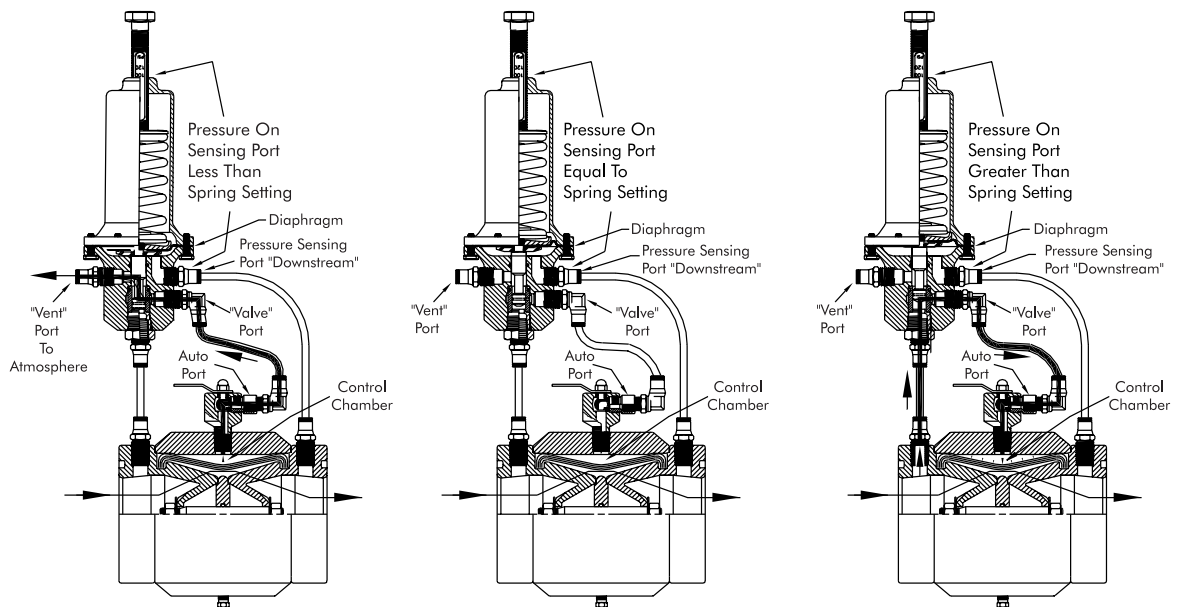

Pressure lower than control set point
The pressure regulating control is temporarily out of balance. The sleeve chamber pressure is opened to vent to the atmosphere.

Pressure same as control set point
The pressure control is in balance.

Pressure higher than control set point
The pressure regulating control is temporarily out of balance. The sleeve chamber pressure is opened to upstream pressure until the set point is reached.

PRESSURE SUSTAINING/RELIEF CONTROL

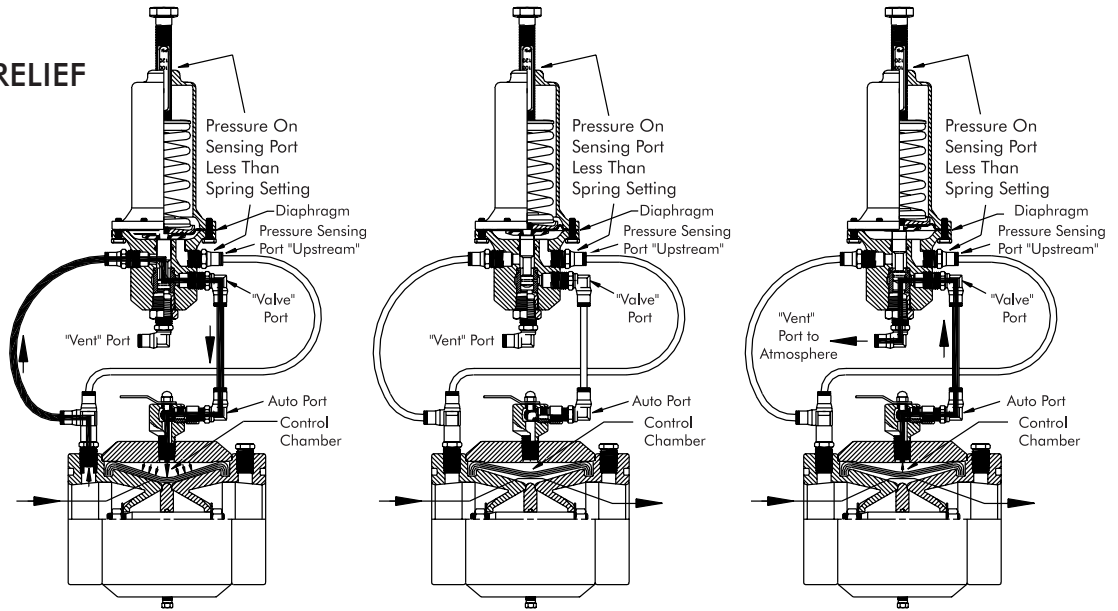

Pressure lower than control set point

The pressure sustaining control is temporarily out of balance. The sleeve chamber pressure is opened to upstream pressure until the set point is reached.

Pressure same as control set point

The pressure control is in balance.

Pressure higher than control set point

The pressure sustaining control is temporarily out of balance. The sleeve chamber pressure is opened to vent to the atmosphere valve opens more.

4.3 PRESSURE CONTROL SENSITIVITY AND ADJUSTMENT

The Nelson 800 Series pressure control is designed with a sensitivity response bushing which can be easily changed to give the valve different sensitivity. A change in sensitivity is useful in solving pressure cycling problems. The drawing in Figure 5 shows the location and options of these bushings. A convenient calibrated scale is provided on the adjustment stem. The scale is useful for approximate pressure setting. It is always recommended that an accurate pressure gauge be used on the valve to set the exact pressure needed. The RED bushing can be used for very accurate pressure control on drip systems. See Section 2.4.3 and also Appendix A for details on the Nelson pressure control accuracy.

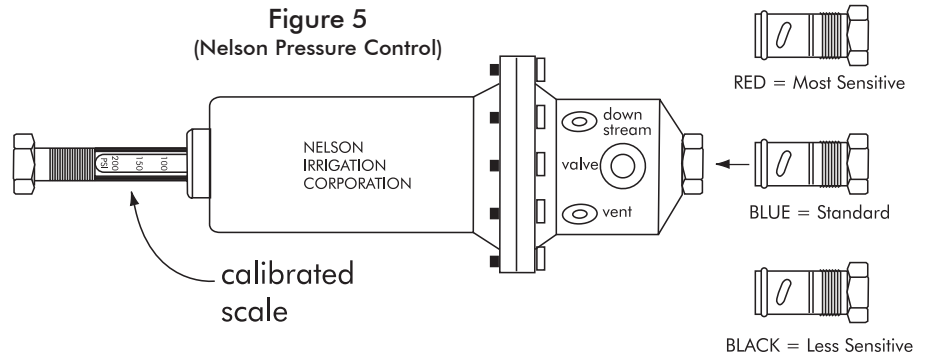

4.4 FILTRATION OF THE CONTROL CIRCUIT WATER

Filtering the water for the pressure control, solenoid and other control components is needed for reliable operation. The internal filter provides some self cleaning and the external filter has the advantage of being cleaned while the system is operating. See Appendix B for a comparison and discussion of the internal and external filter options. See Table 3 for the water volume required to fully open or close valve.

CAUTION! Water sources containing excessive debris should have some filtration.

Table 3

WATER VOLUME REQUIRED TO FULLY OPEN OR CLOSE VALVE	
8"	4 quarts
6"	2 quarts
4"	1 pint
3"	1 cup
2"	5 oz. (145ml)

Large pieces of trash and debris (1/2 inch or bigger) can get caught in the upstream side of the valve cage. The result is partial blockage and extra pressure loss through the valve. If this condition happens then the material can be easily removed by taking the valve out of the line and cleaning out the debris.

4.5 VALVES USED IN LOW TEMPERATURE

If the valve is to be used during low temperature (frost control for example) then the controls need to be covered. The surrounding temperature must be high enough to keep ice from freezing in the control tube. Remember there is very little water flow in the 800 Series controls. The result of ice forming in the control tube is that the valve can not operate correctly. See Appendix B for information on draining external filters.

5.0 ATTENTION TO THE DANGER OF WATER HAMMER AND SURGE

5.1 WATER HAMMER REDUCED BY SMOOTH OPERATION OF THE 800 SERIES

Water hammer is the shock caused by suddenly arresting the flow of water in a pipe. This could happen by rapidly filling a long pipe or in the case of pump shut down where water begins moving back toward a pump before a check valve can close. The most likely time for water hammer to occur is the period of time during start-up and shut down of a system. The valve ON/OFF speed has a great affect on water hammer. Entrapped air rapidly moving within a system can also be a cause of water hammer. The rapid start up of a pump can cause water hammer in the case where no valve is used.

Severe water hammer can cause damage to pipes, pump, pressure regulators and seals. The water hammer shock waves move at the speed of sound in water (4660 ft./sec.). The time to control the wave is during the design. General rules of thumb are: (1) control the start-up so that in filling a long pipe system, no more than 1 1/2 times operating capacity (flow) is used; The Nelson RATE-OF-FLOW can be used to automatically fill the pipe at a rate 10%-15% above operating flow. (2) limit flow velocity in the pipe to 6 ft./sec. or lower. (3) Select the Nelson 800 Series valve that has been designed for smooth operation on opening and closing (See Figure 6 showing closing speed of Nelson compared with other brands).

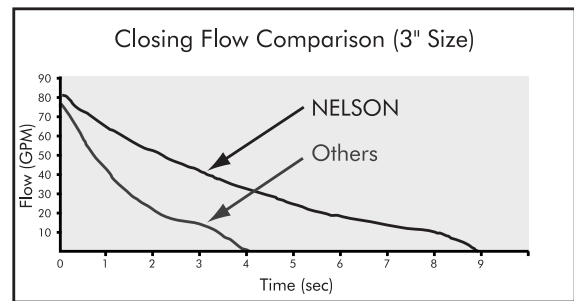
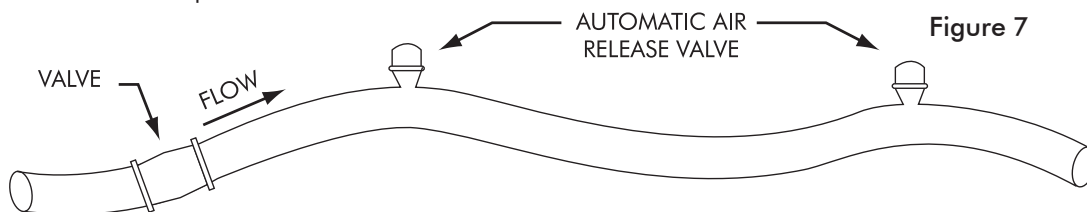

Figure 6

5.2 USE AIR VENTS TO PREVENT AIR ACCUMULATION

The sudden release of air in a system can cause pipe failure. Air control valves are necessary to allow air to escape and to prevent a vacuum pressure which can collapse plastic pipe. The Nelson ACV200 air control valve should be at high points in the piping, at extreme increases in pipe grade, downstream of valves which could possibly slam shut, and downstream of pipe where the flow could trap air. The ACV200 is a combination air relief and air release valve design to solve both air entrapment and vacuum problems.



5.3 SOME THINGS WHICH CAN HELP REDUCE THE DANGER OF WATER HAMMER

- Select a slow opening/closing control on the valve or manually throttle the valve during opening.
- Use a two stage opening electric timer to fill the system. See SPECIAL ON/OFF modes (section 2.4.2)
- Use check valves to keep water in the bulk of the pipe system in order to minimize filling time.
- Use combination air controls which both release air and act as a vacuum breaker. Place vents at all needed locations.

5.4 PRESSURE CYCLE INDUCED BY THE ELASTICITY OF HOSE AND TUBING

Micro-irrigation zone pressure control valves can experience pressure cycling due to the elastic nature of the tubing. In the event a large zone of micro/drip tubing is empty, the valve will fill the tube using full flow. When the tubes are full the pressure expands the tubes much like a balloon. The valve will respond late to over pressure situation. Due to the elasticity of the tube the valve may even shut-off until the pressure in the tube drops below the set point at which time the cycle again starts.

- The problem is best handled by slow filling of the zone. (Many times slow filling is not an option because of the need to have frequent irrigation.)
- Use a design which keeps the zones small to help reduce the problem.
- An excellent way to optimize the filling time and reduce the pressure cycle potential is by use of a RATE-OF-FLOW control option.

6.0 ELECTRICAL APPLICATIONS

Valves can be equipped with optional electric solenoids for remote operation. Controllers and electric remote control valves must be properly wired together, otherwise operation of the system will be affected and become unreliable. Controllers are furnished standard with a nominal input voltage rating of 115 volts AC, 60 Hz (Hertz or cycles) and an output of 24 volts AC on the secondary side for powering electric valve solenoids. There are many optional input voltages in both 50 and 60 Hz. Most solenoids will work with both 50 and 60 Hz. Start by understanding the needs for the controller. Some controllers will only operate one valve per station. Select a controller which not only has the number of zones required but also can operate the number of valves required per station.

The current draw will vary with make and model, depending on the amount of current required to operate the controller itself and the number of valves that the controller is designed to operate per station. A qualified licensed electrician should be employed to install and connect the controller to an adequate power source in compliance with local codes. For the average system, wire size for the controller power supply is governed by local codes. The proper wire size must be calculated for the controllers at remote distances from the power source. This application guide will not address the controller input wire size requirement but will restrict the discussion for sizing of wire to the wire size required from the controller to the valve solenoids.

6.1 VALVE WIRING (FROM THE CONTROLLER TO THE VALVE)

The most common NELSON 800 Series solenoid used on a zone control valve is the 24 VAC (part #7510-015). Two wires are required to provide the secondary low voltage power supply for these valve solenoids. The "common wire" serves all solenoids. A "power" or "hot" wire from the controller to each solenoid completes the circuit. A typical wiring schematic for one valve operating is shown in Figure 8.

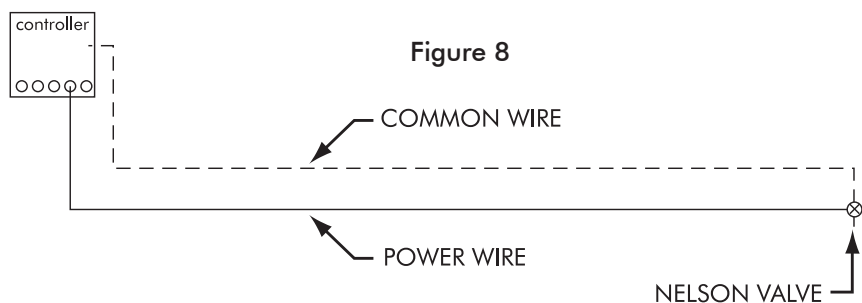

6.2 METHODS OF WIRE SIZING

The following gives two methods of wire sizing which will result in minimum wire size and therefore selection of the wire size of least cost. Tables can be used to select wire size for simple systems. When the wire run distances exceed those given in the tables or for more complicated systems, the wire sizing must be calculated using formulas. Formula usage will be explained later.

6.2.1 WIRE SIZING WITH TABLES

Table 4 has been prepared for the Nelson 24 VAC solenoid (part #7510-015). This table makes selection of wire size simple. The calculations for Table 4 are made to assure that adequate voltage (20.4 VAC) and inrush current (~0.3 amps) will be available to the solenoid. Note other assumptions listed at the bottom of the table.

EXAMPLE: Find the maximum length of run for a system with 150 PSI maximum line pressure using 12 AWG size wire.
 SOLUTION: Enter the 150 PSI chart of Table 3, follow the 12 AWG row to the 12 AWG column and read the answer for maximum length of run of 3497 feet.

Table 4 — GUIDE FOR MAXIMUM LENGTH OF WIRE RUN
NELSON 800 SERIES SOLENOID

Option E40 and E41 (one valve operating)

MAXIMUM LENGTH (FEET) OF RUN (distance from controller to valve) **FOR VARIOUS WIRE SIZES** (for 24VAC solenoid -- OPTION E40 Inrush 0.3A)

Common Wire AWG	Power Wire *AWG						
	18	16	14	12	10	8	6
18	1093	1342	1566	1751	1893	1993	2059
16	1342	1736	2132	2490	2786	3009	3163
50 PSI							
maximum	14	1566	2132	2760	3392	3966	4434
line pressure	12	1751	2490	3392	4399	5416	6328
	10	1893	2786	3966	5416	7047	8672
	8	1993	3009	4434	6328	8672	11270
	6	2059	3163	4775	7047	10081	13772

**LOW POWER
SOLENOID**

* AWG = American
Wire Gage size

Common Wire AWG	Power Wire *AWG						
	18	16	14	12	10	8	6
18	869	1066	1245	1392	1504	1584	1637
16	1066	1380	1694	1979	2215	2392	2514
14	1245	1694	2194	2696	3153	3524	3796
150 PSI							
maximum	12	1392	1979	2696	3497	4305	5030
line pressure	10	1504	2215	3153	4305	5601	6893
	8	1584	2392	3524	5030	6893	8958
	6	1637	2514	3796	5601	8013	10947

MAXIMUM LENGTH (FEET) OF RUN (distance from controller to valve) **FOR VARIOUS WIRE SIZES** (for 24VAC solenoid -- OPTION E41 Inrush 1.1A)

Common Wire AWG	Power Wire *AWG						
	18	16	14	12	10	8	6
18	246	302	353	395	427	449	464
16	302	391	481	561	628	678	713
14	353	481	622	765	894	1000	1077
150 PSI							
maximum	12	395	561	765	992	1221	1427
line pressure	10	427	628	894	1221	1589	1955
	8	449	678	1000	1427	1955	2541
	6	464	713	1077	1589	2273	3105

**HIGH POWER
SOLENOID**

ASSUMPTIONS MADE IN CALCULATIONS: Controller minimum output 24VAC. The allowable minimum voltage required at the solenoid is 20.4 VAC. The table gives the maximum distance in feet from the controller to the valve even though calculations for this table include total wire length from the controller to the valve and return. Common and power wire are assumed to be the same length and one solenoid operating. Specific wire resistance is for solid copper wire at 85 deg. F. (29 deg. C). This table is based upon inrush current required for Nelson #7510-015 solenoid.

EXAMPLE OF USING TABLE 4: Enter the table for 50 PSI maximum line pressure. Find the maximum length of wire run (distance from controller to valve) using 14 AWG power wire and 16 AWG common wire is 2132 feet.

In the event that the controller has a higher voltage output than 24 VAC, longer wire runs can be made. See Table 5 for the multiplier which can be used in conjunction with Table 4 to give the maximum length of run for controllers with higher voltage output.

EXAMPLE: If the controller voltage output is 27 VAC, the lengths in Table 4 can all be increased by a multiplier factor of 1.8.

In the event that there are two valves which must turn on per station; and they are both at approximately the same location, a multiplier factor of 0.46 applied to lengths shown in Table 4 will find the maximum length of run for the wires. The controller current output must be at least 1 amp for both valves per station to work.

Multiplier Factors for Various Controller output Voltages and Optional Solenoids:

Table 5

Controller Output Voltage	24VAC (low power)	24VDC
28	2.1	2.1
27	1.8	1.8
26	1.5	1.5
25	1.28	1.28
24	1.0	1.0
23	0.7	0.7
22	0.44	0.44

Table 6

Maximum Line Pressure	24VAC & DC I _{inrush} current
50 PSI	.248 amps
100 PSI	.278 amps
150 PSI	.312 amps

Table 7

Wire Size AWG	Specific Resistance* Ohms/1000ft
18	6.64
16	4.18
14	2.63
12	1.65
10	1.03
8	0.64
6	0.41

*85° F

6.2.2 WIRE SIZING WITH FORMULAS

When the wire run distances exceed those given in the tables or for more complicated systems, the wire sizing must be calculated using formulas.

Data needed to size wire is:

- (1) the maximum current draw of the valve in amps (I_{inrush}).
- (2) distance in feet (one way) to the valve from the controller (L).
- (3) maximum expected line pressure on the valve solenoid.
- (4) the allowable voltage loss (AVL) in the wire without affecting function of the solenoid .
- (5) controller output voltage (obtained from manufacturer)

The formula for resistance is:

$$R_w = \frac{AVL * 1000}{L * 2 * I_{inrush}} \quad \text{Eq. 1}$$

in which R_w is resistance of the wire (ohms). The "2" in the formula is used to double the length to include the common and power wire of equal length.

EXAMPLE FOR SELECTING WIRE SIZE WITH FORMULAS (ONE VALVE):

STEP 1. Find AVL by subtracting the valve operating voltage (20.4 VAC) from the controller output voltage.
24 VAC - 20.4 VAC = 3.6 VAC.

STEP 2. Determine the inrush current from Table 6. At 100 PSI line pressure it is 0.278 amps.

STEP 3. As an example for 3000 feet wire run calculate $R_w = \frac{(3.6 * 1000)}{3000 * 2 * .278} = 2.16$

STEP 4. The wire resistance must not exceed 2.16 ohms per 1000 feet. Select the proper wire size from Table 7. Since #14 has resistance of 2.63 and this exceeds the 2.16 ohms allowable, select the #12 wire size which is only 1.65.

EXAMPLE FOR SELECTING WIRE SIZE WITH FORMULAS (TWO VALVES):

In the event that there are two valves to turn on per station, the formula procedure is as follows:

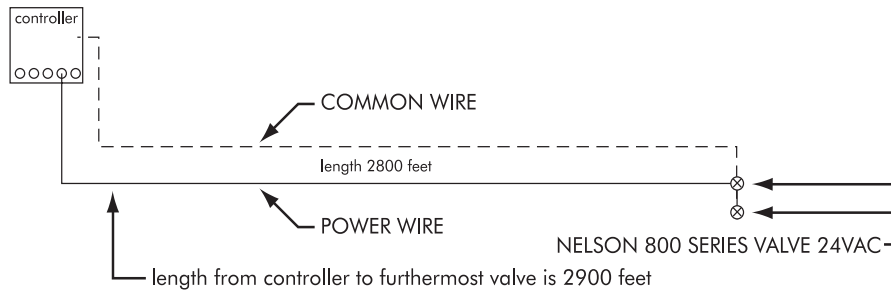

Figure 9

STEP 1 and STEP 2 the same as for one valve shown on the preceding page.

STEP 3. Calculate the allowable wire resistance for the valve furthest from the controller. See the distances shown in Figure 9 schematic. Use the inrush for two valves of $2 * .278 = 0.556$

$$R_w = \frac{3.6 * 1000}{2900 * 2 * 0.556} = 1.12 \text{ ohms/1000 ft}$$

STEP 4. The wire resistance must not exceed 1.12 ohms per 1000 feet. Use Table 6. Select the #10 wire size which is only 1.03 ohms per 1000 feet. Be sure to check the controller output specification for two valves and make any needed adjustment to the AVL.

6.3 WHEN YOU NEED TO USE DC POWER

Certain systems may need to be operated without an AC power source. These may be remote systems where generated power is used, only solar power is available or where DC batteries are used. Option E20, E21, E23, E24 and E30 can be selected for DC power. The power requirements for the E30 option are shown in Table 4. See Table 4 right hand column for multiplier factors. The E23 and E24 are two wire and the most common latching solenoids. Latching means that the holding power is much less than the inrush power required to move the solenoid plunger. Very low holding power is desired to reduce draw down of the batteries or storage units. Two wire controls are more common and easier to purchase worldwide.

THREE WIRE LATCHING OPERATING PRINCIPLE: Option E20 is a three wire latching solenoid. The solenoid is a bi-stable plunger type solenoid with two coil windings. The following applies to the E20 solenoid.

- A pulse applied to terminals 2 and 3 of the operating coil connects port A (which goes to the AUTO port on the manual selector) and R (which goes to the upstream). The valve remains in the operated position.
- A pulse applied to terminals 1 and 3 of the operating coil connects port A (which goes to the AUTO port on the manual selector) and P (which goes to the VALVE port on the pressure regulator). The valve remains in the non-operated position.
- Simultaneous voltage to both coil windings (1 and 2) must be avoided. Nelson Irrigation Corporation has on going evaluation of latching solenoids to find the best for your application. Contact the factory for more details on the power requirements of the E20 option.

SAFETY FIRST!

Always exercise good safety procedures. Persons operating the system, should be warned that personal injury may result from the high pressure water and potential electrical shock.

- Read all warning labels and cautions!
- Never remove or modify the valve under pressure.
- Be sure water flow through the valve has stopped before doing any work on the system downstream.
- Electrical components near water always creates a special danger! Use good electrical safety practices!
- Respect local code requirements.

PRESSURE CONTROL REPLACEABLE SENSITIVITY BUSHING

This sensitivity bushing is designed to be easily replaced and is used to change the pressure control response in order to solve pressure cycling problems or to make the valve more accurately control pressure.

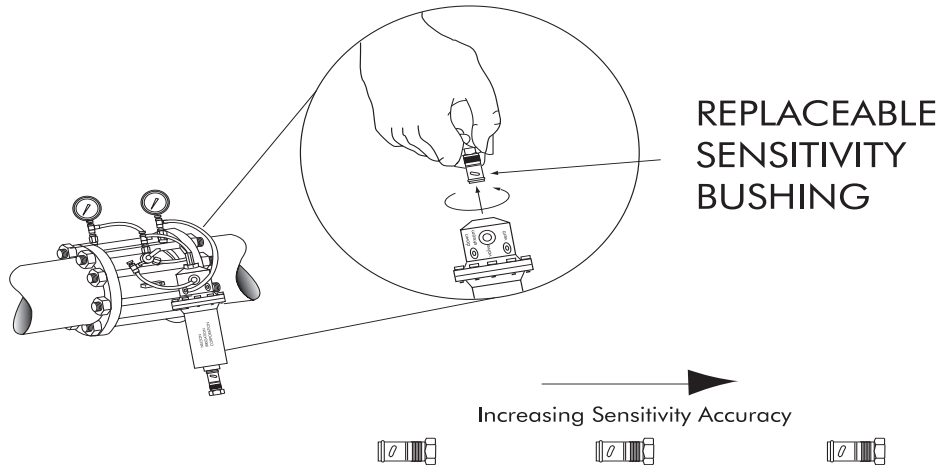

PRESSURE CONTROL OPTION	BLACK least accurate, dampens oscillations	BLUE standard accuracy, good all around	RED maintains the most accurate pressure (use if fastest response is desired)
5 - 50 PSI (0.3 - 3.4 BAR)	± 2 PSI (± 0.13 BAR)	± 1.5 PSI (± 0.10 BAR)	± 1 PSI (± 0.07 BAR)
10 - 120 PSI (0.7 - 8.3 BAR)	± 6 PSI (± 0.41 BAR)	± 4.5 PSI (± 0.31 BAR)	± 3 PSI (± 0.21 BAR)
10 - 200 PSI (0.7 - 13.8 BAR)	± 9 PSI (±0.62 BAR)	± 7 PSI (±0.48 BAR)	± 4 PSI (±0.28 BAR)

EXAMPLE:

A DRIP IRRIGATION SYSTEM REQUIRING 10 PSI: THE UPSTREAM PRESSURE DOES NOT CHANGE DRAMATICALLY WITH CHANGES IN FLOW RATE. THE VALVE IS CLOSE TO THE DRIP TAPE. CHOOSE THE 5-50 PSI PRESSURE CONTROL BECAUSE IT WILL MAINTAIN 10 PSI MORE ACCURATELY THAN THE HIGHER PRESSURE CONTROLS. CHOOSE THE RED SENSITIVITY INSERT TO FURTHER INCREASE THE ACCURACY OF DOWNSTREAM PRESSURE.

A DEEP WELL TURBINE FEEDING SOME WHEEL LINES AND A PIVOT: THE UPSTREAM PRESSURE VARIES SIGNIFICANTLY WITH CHANGING FLOW RATE AND LONG MAINLINES ARE USED. CHOOSE THE 25-200 PSI PRESSURE CONTROL BECAUSE IT WILL NOT TRY AND MAKE SMALL CHANGES TO THIS VERY DYNAMIC SYSTEM. USE THE BLACK SENSITIVITY INSERT TO FURTHER DAMPEN THE PRESSURE CONTROLS RESPONSE. THIS SYSTEM IS LIKE A LONG FREIGHT TRAIN ... IT IS NOT ALWAYS CONSTRUCTIVE TO MICRO MANAGE THE PRESSURE.

EXAMPLE 1: A drip irrigation system requiring 10 PSI: the upstream pressure does not change dramatically with changes in flow rate. The valve is close to the drip tape. Choose the 5-50 PSI pressure control because it will maintain 10 PSI more accurately than the higher pressure controls. Choose the red sensitivity insert to further increase the accuracy of downstream pressure.

EXAMPLE 2: A deep well turbine feeding some wheel lines and a pivot: the upstream pressure varies significantly with changing flow rate and long mainlines are used. Choose the 25-200 PSI pressure control because it will not try and make small changes to this very dynamic system. Use the black sensitivity insert to further dampen the pressure controls response. This system is like a long freight train ... it is not always constructive to micro manage the pressure.

FILTER SELECTION FOR THE 800 SERIES VALVE

The purpose of the filter on the valve control package is to protect the electric solenoid valve or pressure control regulator from debris which could clog the small flow passages. Debris stuck in the small ports of the valve or blockage of the flow in the control package could result in failure of the valve to function. Generally, the source of water for the control package is the upstream side of the pipe line in which the valve is installed. There are two styles of filters to select from, the INTERNAL and the EXTERNAL filter. One or both of these filters can be selected on any control function package. Combining the use of both the internal and external filters is possible to achieve additional filtration protection where excessive debris or solids are present in the water. A discussion of the operation of each filter style is shown here.

EXTERNAL FILTER (option H2)

FEATURES: The external style filter is equipped with a 100 mesh screen which gives much greater filter screen surface area than the internal filter. This could mean less frequent cleaning required. The screen can be cleaned by opening the flush valve on the end of the filter. An isolation valve is provided so there is no need to relieve pressure on the pipe line or drain the system to remove and thoroughly clean the screen.

LOW TEMPERATURE CAUTION!

The flush valve needs to be open so the external filter can drain for winter storage or if the system water is shut off in freezing temperatures. The internal freeze core is designed to reduce the danger of solid ice breaking the brass housing. Drainage is the best procedure to avoid damage. If the valve is to be used during low temperature frost control then the controls need to be covered. The result of ice forming in the control tube is that the valve can not operate correctly.

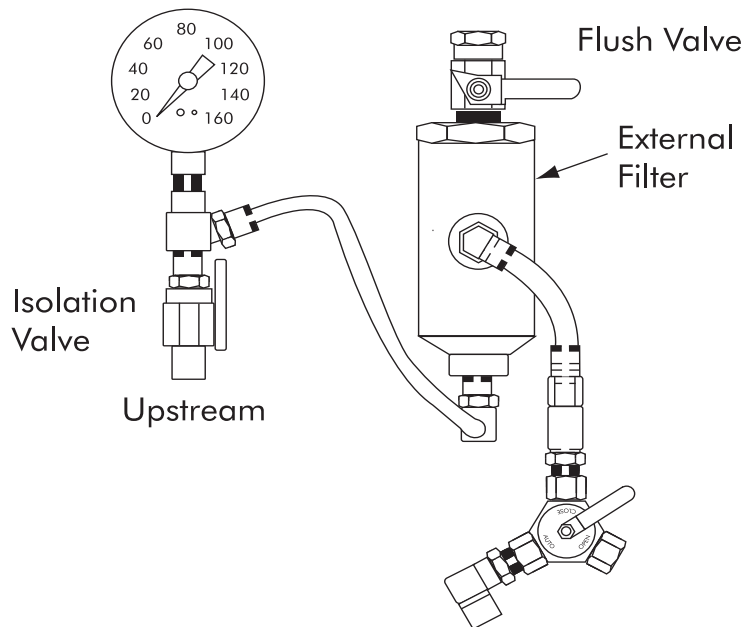

INTERNAL FILTER (option H3)

FEATURES: The internal filter is designed to self clean. The 100 mesh screen protrudes into the main flow of water. The flow-by of water in the pipe may wash off debris from the screen. If the water is fairly clean, the internal screen may never need cleaning.

NOTE: The pipe pressure must be shut off to remove and thoroughly clean the screen.

The internal filter (option H3) is shipped as standard.

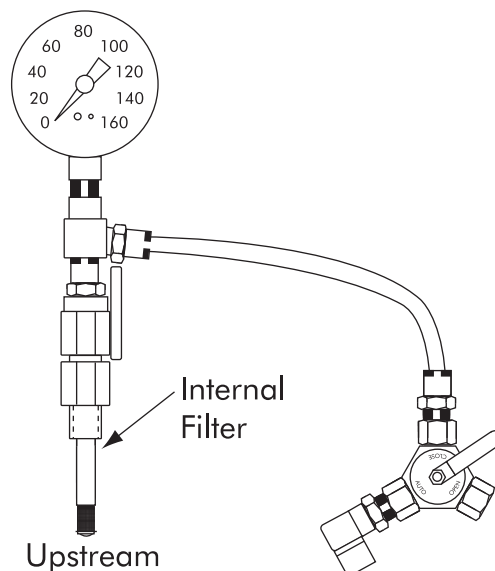

FLOW PATHS AND PORTS FOR CONTROL COMPONENTS

Solenoids — Solenoid valves control the automatic switching which, when electrically energized or de-energized, either shutoff or allow flow in the control tube.

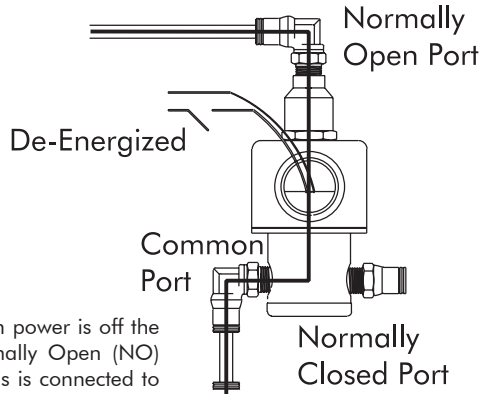

When power is off the Normally Open (NO) port is connected to common. The NO port is generally attached to upstream.

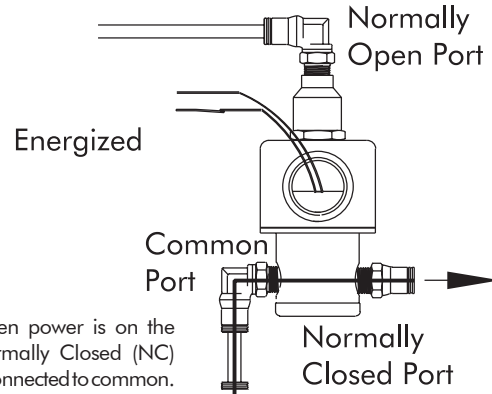

When power is on the Normally Closed (NC) is connected to common. The NC port is attached to the auto port of manual selector valve.

Reducing Pressure Control

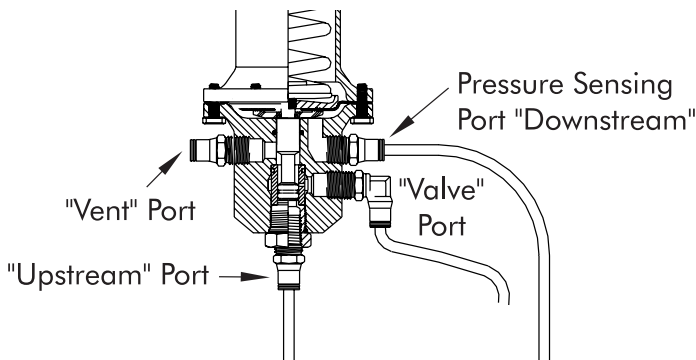

Sustaining Pressure Control

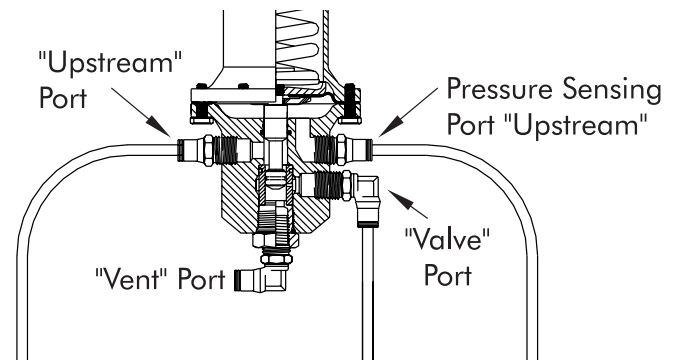

The same pressure control is used for both the reducing and sustaining. Only the port label and hook up of the tubing varies. Conversion from reducing to sustaining is made easy by using the #9519 label.

Manual selector valve

Pointing the selector to the port connects that port to the common port. Intermediate position holds the valve steady.

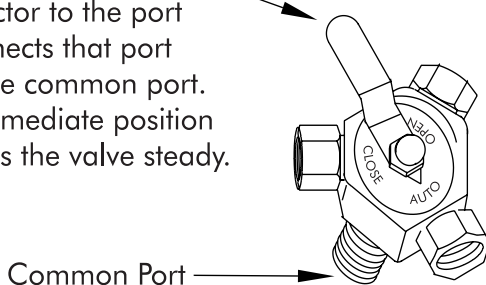

Remote hydraulic relay

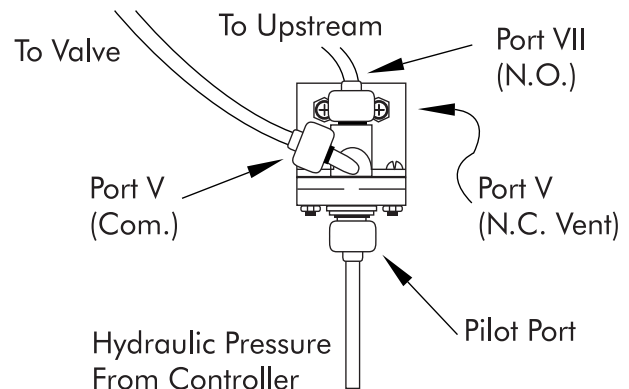

SPECIAL FUNCTION LOOKUP TABLE

This is the special function quick search table. It is helpful in finding the possible functions which are available. Contact the factory for any additional information needed on each setup.

"S" CODE	FUNCTION					FILTER	
	REDUCING CONTROL	SUSTAINING CONTROL	COMBO: REDUCING/ SUSTAINING	AUTOMATIC ON/OFF	CHECK VALVE	INT.	EXT.
S1				◆		◆	
S2				◆		◆	
S4		◆		◆		◆	
S5 ^A		◆				◆	
S6				◆		◆	
S7	◆◆					◆	
S8		◆		◆	◆	◆	
S9		◆		◆◆		◆	
S10	◆			◆ hydr. relay	◆	◆	
S12 ^B			◆	◆		◆	
S13	◆			◆◆		◆	
S14				◆		◆	
S15	◆◆			◆		◆	
S16		◆◆		◆		◆	
S17 ^B			◆	◆			◆
S18 ^A		◆					◆
S19 ^C		◆		◆		◆	
S20	◆			◆		◆	
S21 ^D		◆		◆		◆	
S22 ^E	◆			◆		◆	
S23 ^E	◆			◆			◆
S24 ^F	◆			◆		◆	
S25			◆	◆			
S26 ^F	◆			◆			◆
S27 ^C		◆		◆			◆
S28 ^G			◆	◆		◆	
S29 ^G			◆	◆			◆
S30			◆			◆	
S31				◆		◆	
S32 ^D		◆		◆			◆
S33		◆		◆		◆	
S34	◆				◆	◆	
S37				◆◆		◆	
S38	◆ surge anticipator			◆◆		◆	
S39	◆			◆◆		◆	
S40			◆	◆	◆	◆	
S41		◆		◆	◆		◆
S42		◆		◆	◆	◆	
S43			◆ backflush control	◆		◆	
S44				◆ normally open		◆	
S45				◆ normally open			◆
S46	◆			◆ normally open			◆
S47				◆ normally open rate of flow			◆
S48		◆		◆ normally open		◆	

Corresponding letters on the "S" Codes (example S5^A & S18^A) refers to similar controls. ◆◆ Indicates that there are dual pressure controls or dual solenoids.

MATERIALS LIST FOR THE 800 SERIES VALVE



PART	SIZE				
	2" VALVE	3" VALVE	4" VALVE	6" VALVE	8" VALVE
HOUSING JACKET	Anodized Aluminum	Anodized Aluminum	Anodized Aluminum	Galvanized Steel	Galvanized Steel
CAGE	Epoxy Coated Cast Iron	Epoxy Coated Cast Iron	Epoxy Coated Cast Iron	Epoxy Coated Cast Iron	Epoxy Coated Cast Iron
SLEEVE	Natural Rubber	Natural Rubber	Natural Rubber	Natural Rubber	Natural Rubber
CENTER BOLT	Stainless Steel	Stainless Steel	Stainless Steel	Stainless Steel	Stainless Steel
CENTER SEAT	Plastic (UHMW)	Plastic/ Brass	Plastic (UHMW)	Brass	Plastic (UHMW)
PRESSURE CONTROL	Brass, Stainless Steel, Teflon Nitrile Rubber	Brass, Stainless Steel, Teflon Nitrile Rubber	Brass, Stainless Steel, Teflon Nitrile Rubber	Brass, Stainless Steel, Teflon Nitrile Rubber	Brass, Stainless Steel, Teflon Nitrile Rubber
CONTROL TUBING	Nylon	Nylon	Nylon	Nylon	Nylon
TUBE FITTINGS	Nickel Plated Brass	Nickel Plated Brass	Nickel Plated Brass	Nickel Plated Brass	Nickel Plated Brass
ELECTRIC SOLENOIDS*	Brass, Stainless Steel, Nitrile Rubber	Brass, Stainless Steel, Nitrile Rubber	Brass, Stainless Steel, Nitrile Rubber	Brass, Stainless Steel, Nitrile Rubber	Brass, Stainless Steel, Nitrile Rubber

*Contact Factory for Enclosure Options

Selecting the right materials for the job has been a goal of Nelson Irrigation engineers from the start of the design clear through to the final production of the valve. The materials have been selected to give the best service in typical agricultural water. Nelson reserves the right to improve the performance and service life of the 800 Series valves by changing materials as new information becomes available.

PARTS & DIMENSIONS

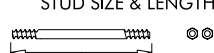
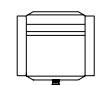
The following table illustrates the dimensions and parts needed for the Wafer, Victaulic and Thread style sleeve valves. The first two columns (BOLT LENGTHS and FLANGE TEMPLATES) refer only to the Wafer style valve. The BOLT LENGTHS column gives the diameters and lengths of the bolts required. The FLANGE TEMPLATES column shows the dimensions of the flange. The VALVE LENGTHS column gives the lengths of the Wafer style as well as the available Victaulic and Thread styles.

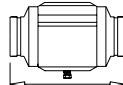
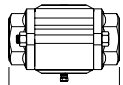
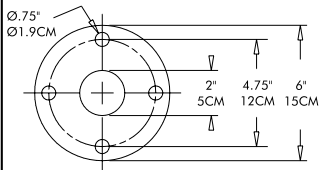
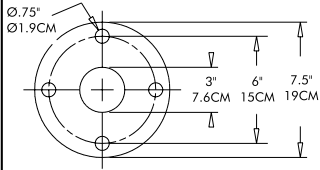
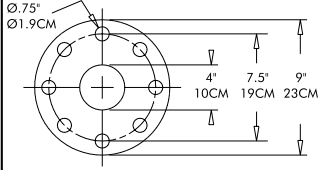
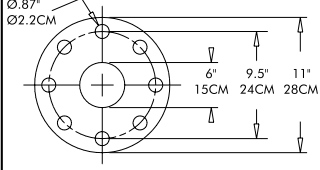
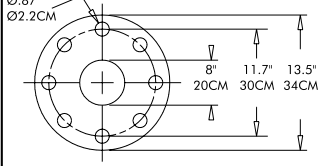
BOLT LENGTHS		FLANGE TEMPLATES	VALVE LENGTHS		
STUD SIZE & LENGTH  USE WASHERS ON PLASTIC FLANGES		FLANGE TEMPLATE FOR USE WITH WAFER STYLE VALVES 	WAFER STYLE VALVE LENGTH 	VICTAULIC STYLE VALVE LENGTH 	THREAD STYLE VALVE LENGTH 
2 INCH VALVE	4 STUDS 5/8" DIA. X 9.5" (1.5 CM X 24 CM) 8 NUTS REQUIRED FOR ANSI GUN ADAPTER USE 4 STUDS 1/2" DIA. X 8.25" 4 WASHERS & 4 NUTS REQUIRED	 Ø.75" Ø1.9CM 2" 5CM 4.75" 12CM 6" 15CM	6.1 INCHES 15.5 CM	8.75 INCHES 22.2 CM	9.1 INCHES 23.1 CM
3 INCH VALVE	4 STUDS 5/8" DIA. X 11" (1.5 CM X 28 CM) 8 NUTS REQUIRED FOR ANSI GUN ADAPTER USE 4 STUDS 1/2" DIA. X 9.75" 4 WASHERS & 4 NUTS REQUIRED	 Ø.75" Ø1.9CM 3" 7.6CM 6" 15CM 7.5" 19CM	7.3 INCHES 18.5 CM	10 INCHES 25.4 CM	9.8 INCHES 24.9 CM
4 INCH VALVE	8 STUDS 5/8" DIA. X 11" (1.5 CM X 28 CM) 16 NUTS REQUIRED GASKETS REQUIRED FOR ANSI GUN ADAPTER USE 4 STUDS 1/2" DIA. X 9.75" 4 WASHERS & 4 NUTS REQUIRED	 Ø.75" Ø1.9CM 4" 10CM 7.5" 19CM 9" 23CM	7 INCHES 17.8 CM	<p>INSTALLATION TIP: When installing the Wafer style valve, do not overtighten the bolt nuts. Overtightening can damage the sleeve. Also note that the 4" valves, (and 6" valves from 1995 and earlier), have gaskets while the other sizes have an o-ring seal. Flush all dirt and debris from the line before operating the valve control. It is suggested the MANUAL ON-OFF selector valve be in the OPEN position for this flushing operation. Failure to flush the line may cause the filter or tubing to clog so that the control function does not work.</p>	
6 INCH VALVE	8 STUDS 3/4" DIA. X 13.5" (1.9 CM X 34 CM) 16 NUTS REQUIRED NO GASKETS REQUIRED ON '96 AND LATER	 Ø.87" Ø2.2CM 6" 15CM 9.5" 24CM 11" 28CM	9.4 INCHES 23.9 CM		
8 INCH VALVE	8 STUDS 3/4" DIA. X 17" (1.9 CM X 43 CM) 16 NUTS REQUIRED	 Ø.87" Ø2.2CM 8" 20CM 11.7" 30CM 13.5" 34CM	12 INCHES 30.5 CM		

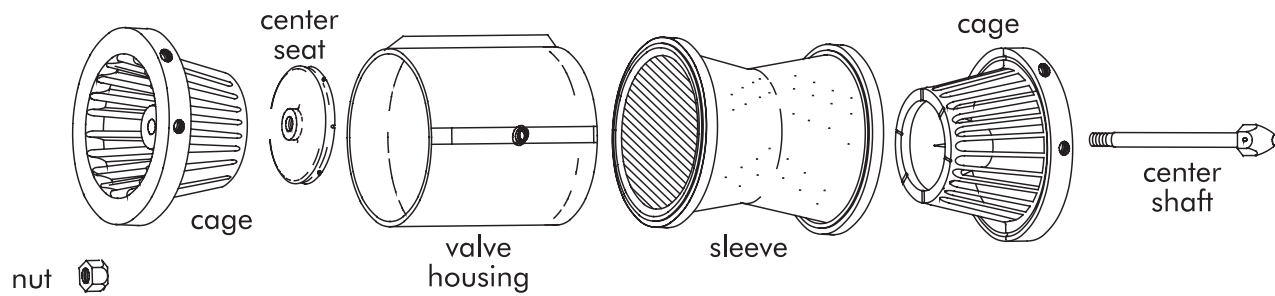

ADDITIONAL INFORMATION

Additional information is available from your irrigation dealer or from Nelson Irrigation Corporation. If you have any questions please call 509-525-7660.

A WORD OF THANKS

Thank you for designing with NELSON IRRIGATION CORPORATION 800 Series Control Valves. Our commitment at Nelson Irrigation Corporation is to provide you with the highest quality products. We work hard at manufacturing and quality assurance to satisfy your requirements. We would appreciate hearing from you. If you have any suggestions for ways to improve our products, this valve application guide, or our service please give us a call at 509-525-7660.

WARRANTY and DISCLAIMER

Nelson Irrigation Corporation 800 Series Control Valves are warranted for one year from date of original sale to be free of defective materials and workmanship when used within the working specifications for which the product was designed and under normal use and service. The manufacturer assumes no responsibility for installation, removal or unauthorized repair. The manufacturer's liability under this warranty is limited solely to replacement or repair of defective parts, and the manufacturer will not be liable for any crop or other consequential damages resulting from any defects in design or breach of warranty.

THIS WARRANTY IS EXPRESSLY IN LIEU OF ALL OTHER WARRANTIES, EXPRESS OR IMPLIED, INCLUDING THE WARRANTIES OF MERCHANTABILITY AND FITNESS FOR PARTICULAR PURPOSE AND OF ALL OTHER OBLIGATIONS OR LIABILITIES OF MANUFACTURER. No agent, employee or representative of the manufacturer has authority to waive, alter or add to the provisions of warranty, nor to make representations or warranty not contained herein.



Nelson Irrigation Corporation

848 Airport Road, Walla Walla, WA 99362-2271, U.S.A.

Tel: 509.525.7660 Fax: 509.525.7907 E-mail: info@nelsonirrigation.com

www.nelsonirrigation.com