

IDR/FOGLIA®

G2
75-300

3" OD x 985 ft
Komet Twin 101 Ultra
80-180 GPM



 Product Page

FEATURES:

- 985 ft – Impact resistant MPDE hose
- Galvanized Frame
- 3-wheel sprinkler cart with adjustable track
- High efficiency turbine drive
- 4-Speed gearbox
- Automatic retraction stop
- Auxiliary PTO powered retraction system
- Automatic retraction speed compensation
- Komet Twin 101 Ultra sprinkler
- 360 Degree rotating turn table
- Stabilizer legs and sprinkler cart
- Chain driven hose guide
- Optional IdroMop Computer control



WaterTec

watertecna.com



877-591-4790



888-695-7999

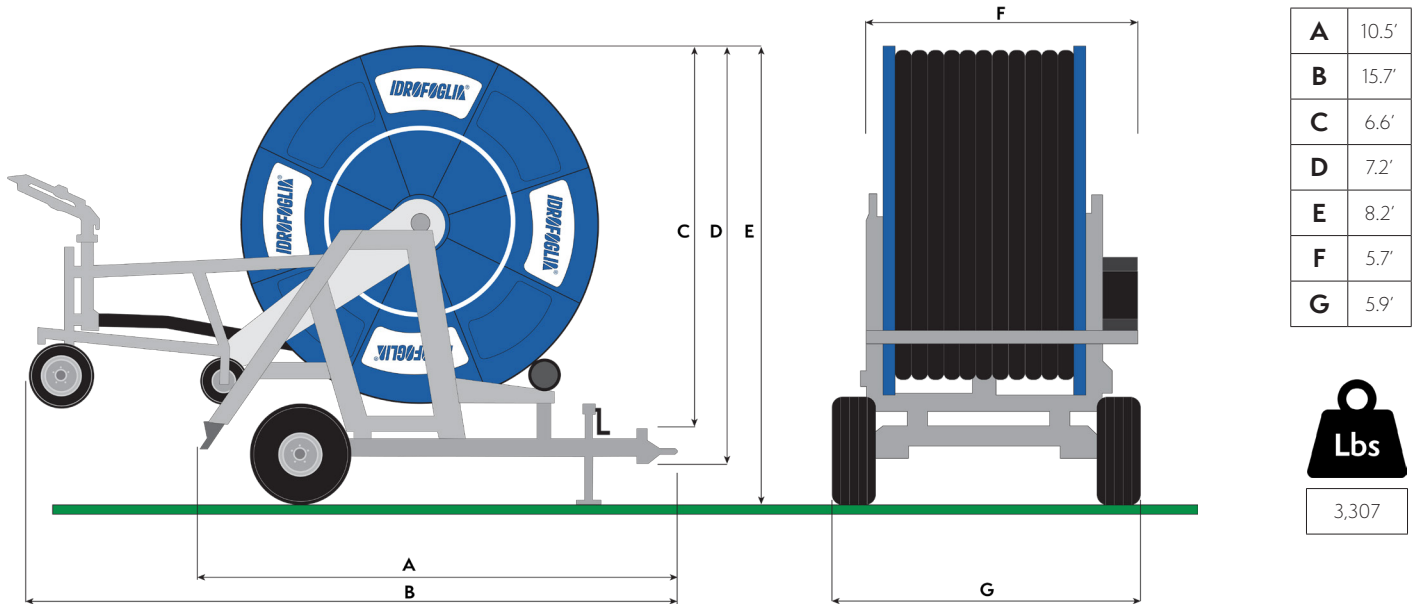

Nozzle Size	Inlet	Sprinkler	Flow	Radius	Diameter	Spacing (8.5%)	Speed (feet/hour)												
							16	33	49	66	82	98	131	164	197	230	262	295	328
							Rewind Time (hours)												
							18.3	9.1	6.1	4.6	3.7	3.0	2.3	1.8	1.5	1.3	1.1	1.0	0.9
mm/in	PSI	PSI	GPM	Feet	Feet	Feet	Precipitation rate in inches												
16 0.63	66	44	80	98	197	167	2.81	1.40	0.94	0.70	0.56	0.47	0.35	0.28	0.23	0.20	0.18	0.16	0.14
	84	59	93	112	223	190	2.87	1.43	0.96	0.72	0.57	0.48	0.36	0.29	0.24	0.20	0.18	0.16	0.14
	103	74	103	118	236	201	3.02	1.51	1.01	0.76	0.60	0.50	0.38	0.30	0.25	0.22	0.19	0.17	0.15
18 0.71	72	44	100	105	210	178	3.28	1.64	1.09	0.82	0.66	0.55	0.41	0.33	0.27	0.24	0.20	0.18	0.17
	91	59	111	115	230	195	3.33	1.67	1.11	0.83	0.67	0.56	0.42	0.33	0.28	0.24	0.21	0.19	0.17
	113	74	129	125	249	212	3.56	1.78	1.19	0.89	0.71	0.59	0.44	0.35	0.30	0.26	0.22	0.20	0.18
20 0.79	81	44	121	108	217	184	3.87	1.94	1.29	0.97	0.78	0.65	0.48	0.39	0.32	0.28	0.24	0.22	0.19
	104	59	140	121	243	206	4.00	2.00	1.33	1.00	0.80	0.67	0.50	0.40	0.33	0.28	0.25	0.22	0.20
	128	74	157	135	269	229	4.03	2.01	1.34	1.01	0.81	0.67	0.50	0.40	0.33	0.29	0.25	0.22	0.20
22 0.87	88	44	138	121	243	206	3.92	1.96	1.31	0.98	0.78	0.65	0.49	0.39	0.33	0.28	0.24	0.22	0.20
	115	59	159	135	269	229	4.09	2.05	1.37	1.02	0.82	0.68	0.51	0.41	0.34	0.29	0.26	0.23	0.20
	140	74	178	148	295	251	4.17	2.09	1.39	1.04	0.83	0.70	0.52	0.42	0.35	0.30	0.26	0.23	0.21