



Name: TURBOCAR

Models: IG1.1-IG1.1S-IG1-IG1S-IG2-IG3-IG4-IG5



IDROFOGLIA S.r.l.
Via Provinciale, 14
61026 Lunano PU - Italy
Tel: +39 0722 700311 - Fax: +39 0722 700309
Website: www.idrofoglia.com Email: staff@idrofoglia.com

eptagruppo.com



I	CONTENTS
----------	-----------------

PAR.	DESCRIPTION
-	Contents

Parts of the manual		Revision				
Contents		0.0				
Chapter	0	0.0				
	1	0.0				
	2	0.0				
	3	0.0				
	4	0.0				
	5	0.0				
	6	0.0				
	7	0.0				
	8	0.0				
	9	0.0				
Instruction Manual Revision		0.0				
Date		7/03/2017				

0 FOREWORD

1. Purpose of the instruction manual
2. How to read the instruction manual
3. Storage of the instruction manual
4. Update of the Instruction Manual
5. Recipients
6. Glossary and pictorials

1 GENERAL INFORMATION

1. Manufacturer's identification data
2. Machine identification data and plates
3. Declarations
4. Safety Regulations
5. Information on technical support

2 DESCRIPTION OF THE MACHINE

1. Operating principle
2. Main components
3. Dimensions
4. Environmental conditions
5. Sound emissions
6. Technical specifications
7. Tools
8. Panels and buttons
9. Standard supply
10. Accessories

3 SAFETY

1. General warnings
2. Intended use
3. Contraindications for use
4. Hazardous areas
5. Safety devices
6. Signs
7. Residual risks

4 INSTALLATION

1. Checking the material upon delivery
2. Storage and unpacking
3. Lifting, handling and unloading
4. Transport
5. Assembly
6. Connecting the battery
7. Topping up and filling the battery
8. Commissioning

5 USE OF THE MACHINE

1. Checks and preparation prior to start-up
2. Starting up
3. Adjustment instructions
4. Turning off

6 MAINTENANCE

1. General warnings
2. Maintenance

7 SPARE PARTS AND ACCESSORIES

1. Support

8 SUPPLEMENTARY INSTRUCTIONS

1. Waste disposal
2. Decommissioning and disposal
3. Safe work procedures

0	FOREWORD
---	-----------------

PAR.	DESCRIPTION
1	Purpose of the instruction manual

1. PURPOSE OF THE OPERATING AND MAINTENANCE INSTRUCTION MANUAL.

We would like to thank you for the trust you have placed in us by purchasing this new turbocar. This Instruction Manual is an integral part of the Machine and has the purpose of providing all the required information for:

- correctly raising operators' awareness on safety issues;
- handling the packed and unpacked machine in safe conditions;
- correct Machine installation;
- thorough knowledge of its operation and limitations;
- its correct use in safe conditions;
- perform maintenance operations in a correct and safe manner;
- dismantle the Machine in safe conditions and in compliance with the regulations in force protecting workers' health and the environment.



The managers of the company where this Machine is to be installed are obliged – in compliance with regulations in force – to carefully read this document and ensure operators and maintenance technicians read the parts that concern them. The time used will be widely made up for by proper machine operation and use in safe conditions.

This document assumes the regulations in force on occupational health and safety are complied with in the workplace where the Machine operates.

The instructions, drawings and documentation contained in this Manual are of a confidential technical nature, strictly owned by the manufacturer and may not be reproduced in any way either wholly or in part.

0	FOREWORD
----------	-----------------

PAR.	DESCRIPTION
2	How to read the instruction manual

2. HOW TO READ THE INSTRUCTION MANUAL.

The Manual has been divided into independent chapters, each aimed at a specific operator role (INSTALLER, OPERATOR AND MAINTENANCE TECHNICIAN), for whom the skills required to operate safely on the machine have been defined.

The sequence of chapters adheres to the temporal logic of the Machine’s service life.

To promote easy understanding of the text, terms, abbreviations and pictorials are used, the meaning of which is set out in par. 6.

The Instruction Manual consists of a cover, a table of contents and a series of chapters (sections).

The first page shows the models, revision of the Instruction manual, to help the reader identify the machine and relevant manual.

PAGE NUMBERING

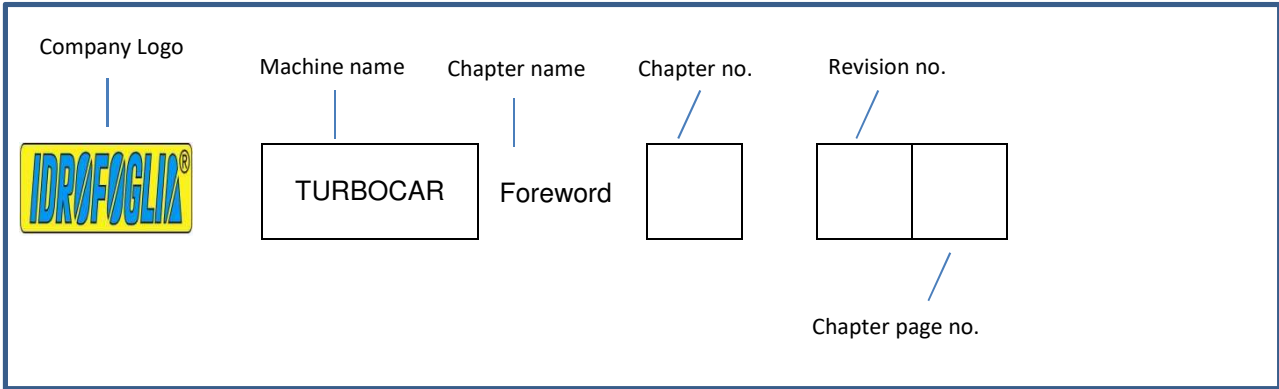

PICTURE NUMBERING

Each picture is numbered progressively.
Numbering consists as follows:

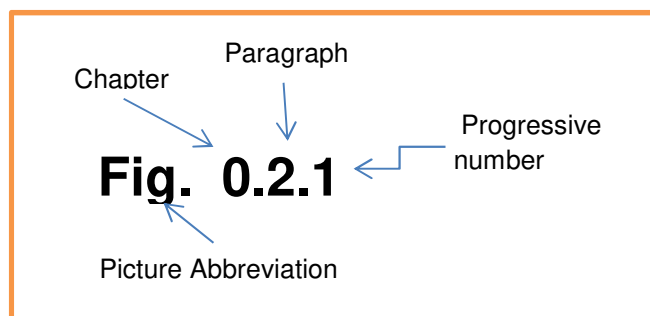
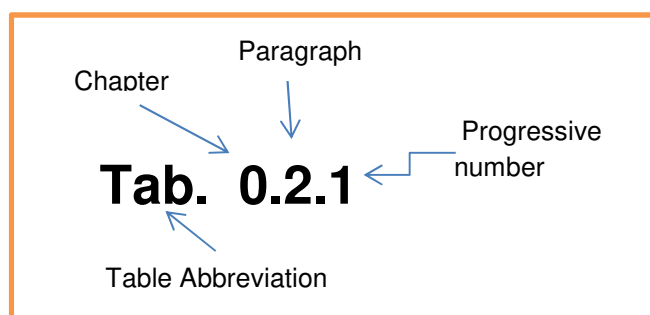

TABLE NUMBERING

Each table is numbered progressively.
Numbering restarts from “1” at each new section.
Numbering consists as follows:



ABBREVIATIONS

Sec. = section
Ch. = chapter
Par. = paragraph
Pg. = page
Fig. = figure
Tab. = table

UNIT OF MEASURE

The units of measure used are those set by the international system (IS).

0	FOREWORD
----------	-----------------

PAR.	DESCRIPTION
3	Storage of the instruction manual

3. STORAGE OF THE INSTRUCTION MANUAL.

The Instruction Manual must be stored carefully and must be provided with the Machine through all changes of ownership it might have throughout its service life.

Preservation must be promoted by handling it with care, with clean hands and by not placing it on dirty surfaces.

No parts must be removed, torn or arbitrarily modified.

The Manual must be stored in premises away from moisture and heat and close to the Machine it covers.

On the User's request, the Manufacturer may provide additional copies of the Machine's Instruction Manual.

0	FOREWORD
----------	-----------------

PAR.	DESCRIPTION
4	Method to update the instruction manual

4. METHOD TO UPDATE THE INSTRUCTION MANUAL.

The Manufacturer reserves the right to modify the project and make improvements to the machine without informing the Customers, and without updating the Manual already delivered to the user. Nevertheless, in the event of modifications to the machine installed at the Customer's premises agreed with the Manufacturer and entailing modification of one or more chapters of the Instruction Manual, the manufacturer shall send to the holders of the Instruction Manual concerned the modified chapters, with its new overall revision model.

It is the User's responsibility to follow the indications provided with the updated documentation and replace the old chapters with the new ones, the first page and the table of contents with the new revision level in all the copies they possess.

The Manufacturer shall be responsible for the description in Italian. Any translations cannot be fully verified, hence should any inconsistency be found, the Italian version prevails. If required contact our Sales department which will make the amendment deemed appropriate.

0	FOREWORD
---	-----------------

PAR.	DESCRIPTION
5	Recipients

5. RECIPIENTS

The Manual in question should be used by the Installer, the Operator and the Skilled Personnel authorised to perform machine maintenance.

It is specified that “**OPERATOR**” refers to the personnel in charge of operating, adjusting, cleaning, performing routine maintenance on the machine.

“**SKILLED PERSONNEL or SKILLED OPERATOR**” refer to the people who have attended specialization, training courses, etc. and have experience in installation, commissioning and maintenance, repair, handling of the machine.

“**HAZARD ZONE**” refers to any area within and/or near a machine where the presence of a person represents a risk for the health or safety of the person.

Qualification of recipients (see PAR. 0.6)

The Machine is intended for agricultural use, therefore professional and not general, hence skilled personnel should be entrusted with its use, specifically they should:

- have reached the age of majority;
- be physically and mentally fit to perform jobs having special technical difficulty;
- have been adequately instructed on machine use and maintenance;
- have been deemed fit and trained by the employer to perform the task entrusted to them;
- are able to understand and interpret the operator manual and safety requirements;
- know the emergency procedures and their implementation;
- have the skills required to operate the specific type of equipment;
- are familiar with the specific applicable regulations;
- have understood the operative procedures set by the machine’s Manufacturer.

0	FOREWORD
---	-----------------

PAR.	DESCRIPTION
6	Glossary and pictorials

6. GLOSSARY AND PICTORIALS

This paragraph lists uncommon terms or however having a meaning other than common. The paragraph below explains the abbreviations and the meaning of the pictorials used to indicate the qualification of the operator and Machine status. They are used to provide quickly and unequivocally the information required for proper use of the Machine in safe conditions.

GLOSSARY

HAZARD ZONE: Area within and/or near a machine where the presence of an exposed person represents a risk for the health or safety of that person;

EXPOSED PERSON: Any person who is entirely or in part in a hazard zone;

OPERATOR: Person in charge of installing, operating, adjusting, performing maintenance, cleaning, repairing and handling the machine.

MAN-MACHINE INTERACTION: Any situation in which an operator interacts with the machine in any operative stage at any time of its service life;

OPERATOR QUALIFICATION: Minimum level of the skills the operator must have to perform the operation described;

NUMBER OF OPERATORS: Adequate number of operators to perform in an optimal manner the operation described and arising from careful analysis performed by the manufacturer, hence using a different number of workers might prevent the expected result from being achieved or jeopardise the safety of the personnel involved;

MACHINE STATUS, refers to:

- the operating mode;
- the condition of the safety devices installed on the Machine.

RESIDUAL HAZARD: Danger that could not be eliminated or reduced sufficiently through design, against which the guards are not (or are not wholly) effective. The manual provides information on its existence and instructions and warnings to address it (see respectively, 5.5 and 5.5.1 of European standards EN 292/1 and EN 292/2);

SAFETY COMPONENT: Refers to a component used to assure a safety function and whose fault or bad operation undermines the safety or health of the exposed persons (e.g. lifting equipment; fixed, movable, adjustable guard, etc., electrical, electronic, optical, pneumatic, hydraulic device that feeds or interlocks a guard etc.);

PICTORIALS

The descriptions preceded by this symbol contain



Very important information/requirements, especially as regards safety. Failure to comply may entail:

- dangers for the safety of operators;
- loss of the contractual warranty;
- disclaimer of manufacturer's liabilities.











SYMBOL	DESCRIPTION
	Machine operator: operator authorised to use the machine (strictly following the manufacturer's instructions), in compliance with the laws in force in the machine user's country.
	Mechanical maintenance technician: skilled technician, able to operate the machine in normal conditions, to act on mechanical parts to perform the required adjustments, maintenance and repairs. Typically, they are not authorised to perform operations on live electrical systems.
	Manufacturer's technician: skilled technician, provided by the manufacturer to perform operations of a complex nature in special situations or however agreed with the user. As the case may be, their skills are mechanical, electrical or electronic.
	Driver of lifting and handling equipment: operator authorised to use lifting and handling equipment for materials and machines (strictly complying with the manufacturer's instructions) in compliance with the laws in force in the machine user's country.

Tab. 0.6.1

SAFETY PICTORIALS

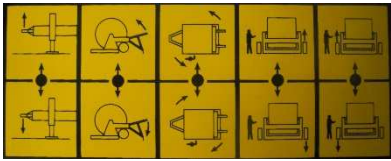
In the event they should be deteriorated or removed, the buyer is obliged to restore with identical signs. Operators are expressly forbidden to remove or tamper with the signs.

SYMBOL	DESCRIPTION
	<p>MAXIMUM PERMITTED TOWING SPEED: placed on the back of the turbocar trolley (if the machine is approved the limit specified on the registration paper/technical annex applies)</p>
	<p>UNAUTHORISED PERSONS MUST NOT STAND NEAR THE MACHINE</p>
	<p>DO NOT CLEAN, GREASE, LUBRICATE, REPAIR OR ADJUST MOVING PARTS BY HAND</p>
	<p>DO NOT REMOVE THE SAFETY DEVICES</p>
	<p>MANDATORY USE OF PROTECTIVE GLOVES</p>
	<p>MANDATORY USE OF SAFETY SHOES</p>
	<p>MANDATORY USE OF PROTECTIVE HELMET IN ACTIVITIES ENTAILING A POSSIBLE RISK OF FALLING MATERIALS</p>
	<p>MANDATORY USE OF PROTECTIVE OVERALLS</p>
	<p>MANDATORY USE OF PROTECTIVE GOGGLES IN ACTIVITIES ENTAILING A POSSIBLE RISK OF LIQUID SPRAYS OR JETS</p>

	<p>OPERATORS MUST ADHERE TO THE INSTRUCTIONS OF THE MACHINE'S OPERATING MANUAL</p>
	<p>GENERIC HAZARD: placed on the machine</p>
	<p>LIFTING HOOK CONNECTION: placed near each connection on the machine's top frame</p>
	<p>CAUTION HOT SURFACES HAZARD : placed on the compressor, if any</p>
	<p>UPPER LIMBS CRUSHING HAZARD: placed near the abutments of the bar joint</p>
	<p>UPPER LIMBS ENTRAINMENT AND DRAGGING HAZARD: placed near moving mechanical parts (roller crown gear-gearbox pinion, roller crown gear-sliding bar pinion drive)</p>
	<p>LOWER LIMBS CRUSHING HAZARD: placed near the drawbar lifting and parking feet</p>
	<p>LEVER CONTROLS: placed near the distributor and identifies the types of possible controls</p>
	<p>GEARBOX ENGAGE/DISENGAGE: placed near the gearbox release lever</p>
	<p>GEAR INDICATOR: placed on the gearbox gear lever (there are gearbox models with 4 gears and models with 2 gears)</p>
	<p>SUMMARY OF INSTRUCTIONS AND WARNINGS: placed near the roller crown gear (<u>grease before use</u>)</p>

	<p>ENTRAINMENT AND DRAGGING HAZARD placed near the PTO shaft</p>
	<p>PRESSURISED DUCTS HAZARD place near ducts that may be released</p>
	<p>DIGITAL METRE COUNTER GRAPH: placed near the digital metre counter (only found on machines with VDO metre counter)</p>
	<p>SUMMARY OF INSTRUCTIONS AND WARNINGS: placed near the turbine, it sums up the basic instructions for turbocar operation (<u>read carefully</u>)</p>
	<p>DANGER DURING USE : placed near the trolley loader</p>



TURBOCAR

General
Information**1****0.0****1/6****1****GENERAL INFORMATION****PAR.****DESCRIPTION**

1

Manufacturer's identification data

1. MANUFACTURER'S IDENTIFICATION DATA

MANUFACTURER

IDROFOGLIA S.r.l.

REGISTERED OFFICE – ACCOUNTS

*Via Provinciale, 14**61026 Lunano (PU) - Italy*

SWITCHBOARD

Tel.: +39 0722/700311**Fax:** +39 0722/700309

CONTACTS

Email: staff@idrofoiglia.com**Website:** www.idrofoiglia.com**GENERAL INFORMATION**

1	GENERAL INFORMATION
PAR.	DESCRIPTION
2	Machine identification data and plates

2. MACHINE IDENTIFICATION DATA

Each machine is identified by a CE plate indelibly marked with the machine's reference data. This plate must never be removed and must always be kept legible. In the event of damage a duplicate must be requested.

<u>Nome ed indirizzo della ditta costruttrice</u>			
MACCHINA SEMOVENTE			
STRUTT.	<input type="text"/>	MOD.	<input type="text"/>
N° SERIE	<input type="text"/>	ANNO COSTRUZ.	<input type="text"/>

1	GENERAL INFORMATION
PAR.	DESCRIPTION
3	Copy of declaration of conformity

3. COPY OF DECLARATION OF CONFORMITY

DICHIARAZIONE DI CONFORMITA'

aggiunta ai sensi della Direttiva 2006/42/CE del Parlamento europeo e del Consiglio del 17 maggio 2006 relativa alle macchine.

Il sottoscritto Costruttore:

Via Provinciale, 14, 61026 LUNANO (PS) ITALY
TEL. 0722/700311 FAX 0722/700309
http://www.idrofoglia.com - e-mail:staff@idrofoglia.com
C.F. P.IVA 00100740414-Ischr.n.1026-Ischr.Trib.Urbino n.33326

DICHIARA

sotto la propria responsabilità che la macchina di seguito descritta:

MACCHINA AGRICOLA SEMOVENTE "TURBOCAR" PER IRRIGAZIONE

STRUTTURA MODELLO

N° SERIE ANNO DI FABBRICAZIONE

è conforme alle seguenti disposizioni pertinenti:

Direttiva 2006/42/CE
del Parlamento europeo e del Consiglio del 17 maggio 2006 relativa alle macchine
Norme armonizzate, norme nazionali e regole tecniche considerate:

UNI EN ISO 12100-1:2005	Sicurezza del macchinario – Concetti fondamentali, principi generali di progettazione Terminologia, metodologia di base.
UNI EN ISO 12100-2:2005	Sicurezza del macchinario – Concetti fondamentali, principi generali di progettazione Specifiche e principi tecnici.
UNI EN ISO 14121-1:2007	Sicurezza del macchinario – Valutazione dei rischi.
UNI EN 908:2001	Irrigatori su carro a naspo - Sicurezza
UNI EN ISO 4254-1:2006	Macchine agricole – Macchine agricole semoventi, portate, semiportate e trainate – Requisiti comuni di sicurezza.
ISO 11684:1995	Trattrici, macchine agricole e forestali, macchine a motore da giardino – Segni grafici per la sicurezza e pittogrammi di segnalazione dei pericoli – Principi generali
UNI EN ISO 5674:2005	Trattrici e macchine agricole e forestali – Protezioni per alberi cardanici di trasmissione della presa di potenza (P.O.P.). Prove di usura e resistenza.
UNI EN ISO 13732-1:2007	Sicurezza del macchinario – Temperature della superficie di contatto – Dati ergonomici per stabilire il valore limite di temperatura per le superfici calde.
UNI EN 982/ 2009	Sicurezza del macchinario. Requisiti di sicurezza relativi a sistemi e loro componenti per trasmissioni oleoidrauliche e pneumatiche. Oleoidraulica.
UNI EN ISO 13849-1/ 2007	Sicurezza del macchinario – Principi generali per la progettazione.
UNI EN ISO 13857	Distanze di sicurezza per impedire il raggiungimento di zone pericolose con gli arti superiori.
UNI EN 349/Nov.2008	Spazi minimi per evitare lo schiacciamento di parti del corpo.
UNI EN ISO 4413	Oleoidraulica regole generali e requisiti di sicurezza per i sistemi e i loro componenti.

DICHIARA INOLTRE CHE:

aggi ai sensi degli Allegati III* e VII* alla Direttiva 2006/42/CE :

- la marcatura "CE" è apposta sulla macchina;
- il Sig. Brugnellini Severino, in qualità di legale rappresentante della stessa, è la persona autorizzata a costituire il fascicolo tecnico.

Redatto in Lunano/...../.....

IDROFOGLIA s.r.l.
Via Provinciale, 14
61026 LUNANO (PU)
Part. IVA 0010074 041 4

GENERAL INFORMATION

1	GENERAL INFORMATION
----------	----------------------------

PAR.	DESCRIPTION
4	Safety regulations

4. SAFETY REGULATIONS

The machine has been constructed in compliance with the safety regulations listed below:

UNI EN ISO 12100	Safety of machinery – Risk assessment and risk reduction
UNI EN ISO 14121-1	Safety of machinery – Risk assessment – Part 1: Principles.
UNI EN 908:2001	Trolley hose reel irrigators - Safety
UNI EN ISO 4254-1	Agricultural machines – Safety – Part 1: General safety requirements
ISO 11684:1995	Tractors, machinery for agriculture and forestry, powered lawn and garden equipment – Safety signs and hazard pictorials – General principles
UNI EN ISO 5674	Tractors and machinery for agriculture and forestry – Guards for PTO drive shafts
UNI EN ISO 13732-1	Ergonomics of the thermal environment – Methods for the assessment of human responses to contact with surfaces – Part 1: Hot surfaces
UNI EN ISO 13849 – 1	Safety of machinery – Safety-related parts of control systems – Part 1: General principles for design.
UNI EN ISO 13857	Safety distances to prevent hazard zones being reached by upper and lower limbs.
UNI EN ISO 4413	Hydraulic fluid power – General rules and safety requirements for systems and their components.

1	GENERAL INFORMATION
PAR.	DESCRIPTION
5	Information on technical support and warranty

5. INFORMATION ON TECHNICAL SUPPORT AND WARRANTY

The machines are covered by warranty as set forth in the general sales conditions.

IDROFOGLIA S.r.l. WARRANTY CONDITIONS

1. The Seller guarantees to the Buyer their final products against faults or malfunctions due to defects in constructions or materials. Any damage, impact or tampering with the material received shall be notified to the Seller within 8 days from receipt of the goods by the Buyer (or recipient) (either in case of Free Port or Freight Collect shipment).
2. The Seller guarantees the final product to the Buyer and for a period of 12 months from the delivery date. Said warranty shall cover all components except motor and pump, for which the warranty stated by the relevant Manufacturers shall apply.
The warranty claim on any component must be submitted directly to the Seller.
3. It is understood that said warranty includes and supersedes the warranties or liabilities set by the Law and excludes any other Seller liability, except the case of the latter's wilful misconduct or gross negligence, either contractual or extra-contractual, however originating from the final product supplied. Therefore, without prejudice to the event of wilful misconduct or gross negligence, the Buyer may not demand compensation for damage, price decrease or termination of the contract. After the term of the warranty has expired, no claim may be put forth against the Seller.
Any defects or malfunctions of the final product shall not entitle the Buyer to discontinue or delay payments thereof, nor of other supplies.
4. The Seller's warranty is excluded hence not applicable in the following cases:
 - a. Should the buyer make modifications or have repairs made on the final product without prior written authorisation by the Seller.
 - b. Should the final product be misused by the Buyer or used otherwise than specified on the Use and Maintenance Manuals (including in the delivery of the final product). Should the Manuals not be provided the Buyer shall be obliged to report it. In this connection, it is pointed out, as specified in the use and maintenance manuals, that prior to using the product the customer or dealer must ensure the finished product is complete with all its parts or components, that all screws are properly tightened and that all gear parts are appropriately lubricated. As a matter of fact, no complaints arising from said failings shall be accepted. Any missing parts shall be reported to the company which, after the due checks, shall send the material.
 - c. In the event the defects or malfunction should be caused by carelessness or negligence in using the final product by the Buyer or wear caused by prolonged use.
 - d. In the event the final product has not undergone maintenance or lubrication servicing solely by authorised personnel or other personnel recognised by the Seller.
 - e. In the event the Buyer has used non original spare parts or made repairs or made modifications with personnel not authorised by the Seller.
 - f. In the event the breakdown or wear of the product arise from inadequate liquids or affecting its duration, such as when irrigating using water that contains traces of sand,

GENERAL INFORMATION



TURBOCAR

General
Information

1

0.0

6/6

algae or other types of foreign matter, or if using fuels or oils that are not appropriate for the motor or pumps they are used for.

- g. In the event the final product is used in places other than agreed, in places that are dusty, brackish, with presence of corrosive substances, high moisture, difficult environmental conditions, low temperature (lower than 0°C) or high temperature (higher than +30°C).
5. By virtue of this warranty, only shipment to the Buyer's premises of components having construction or material defects shall be understood as borne by the Seller. Therefore, should the Buyer require the repair or replacement under warranty at the place where the final product is installed, the transport expenses of the component, the expenses for the authorised personnel (including travel/board and lodging expenses) shall be borne by the Buyer. Furthermore, in the event it should be required to return the components of the final product to the Seller's premises, the costs and expenses for said operation shall be borne by the Buyer.
6. Any servicing under warranty, replacement or repair of components by the Seller do not entail renewal of this warranty.

GENERAL INFORMATION

2

DESCRIPTION OF THE MACHINE
PAR.
DESCRIPTION

1

Operating principle

1. OPERATING PRINCIPLE

Hose reel irrigators mainly consists of a long range irrigator, placed on a rubber wheel trolley connected to a polyethylene hose.

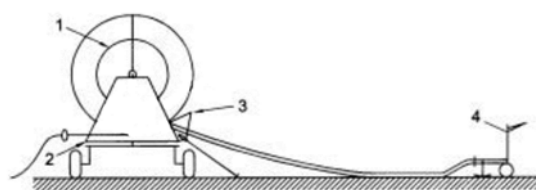

- 1 Winder roller or drum or reel
- 2 Superstructure or upper frame
- 3 Hose guide system
- 4 Long range irrigator



During machine preparation the polyethylene hose is paid out. After that, during irrigator operation, hose reeling in is controlled by the machine onto a horizontal axis drum (roller) placed on a wheeled galvanised steel frame.

In most cases reeling in is hydraulic with turbine.

A motor pump unit may convey pressurised water into the hose.

Adjustment of the winding or reeling in speed (which must be constant for the whole duration of the position) is indispensable in order to assure even water height on the irrigated surface.

Almost all models are fitted with a mechanical type speed regulator: the most widespread regulators are the reel probes (bar joint) that act on bypass.

The Machines have been solely designed and constructed for irrigation of agricultural plots with any kind of crop, parks, sport facilities and hothouses.

They essentially consist of:

- 2.1 turbine;
- 2.2 gearbox with gears in oil bath;
- 2.3 safety devices for PTO and reeling in out of stowed position;
- 2.4 motion drive to the roller via crown gear (double crown for large machines);
- 2.5 hose guide moved by worm screw;
- 2.6 bypass to adjust speed;
- 2.7 glycerine pressure gauge;
- 2.8 digital metre counter;
- 2.9 turntable and holder;
- 2.10 base rotation and lifting/lowering of the trolley loader, of the drawbar lifting foot and of the right and left wheels, actuated by hydraulic system;
- 2.11 trolley loader and parking feet;
- 2.12 2-wheel frame (4 for larger machines) with water system with double inlet;
- 2.13 2-wheel irrigator traveller;
- 2.14 irrigator with set of nozzles;
- 2.15 Polyethylene (PE) hose.

2	DESCRIPTION OF THE MACHINE
PAR.	DESCRIPTION
2	Main components

2. MAIN COMPONENTS

The main components of the TURBOCAR are listed and described below.

2.1 TURBINE

Device consisting of an impeller that exploits water pressure to move the gearbox for roller rotation, so it reels in the PE hose.

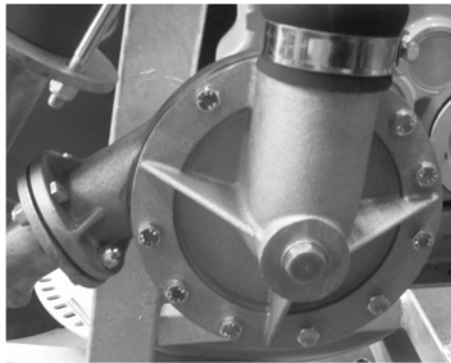

2.2 GEARBOX WITH GEARS IN OIL BATH

Gearbox block connected directly to the turbine, which reduces roller motion for reeling in the PE hose. The gear lever is fitted on the gearbox block, as well as the PTO and the release lever, to stop hose reeling in.

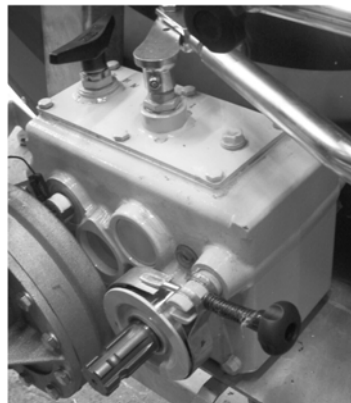

2.3 SAFETY DEVICES FOR PTO AND REELING IN OUT OF STOWED POSITION

Protection cap for the PTO and the mechanical stop system, in the event the hose should come out of the roller (bar joint).

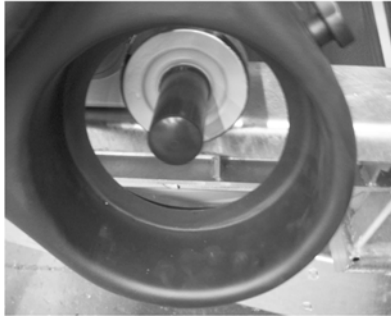

2.4 MOTION DRIVE TO THE ROLLER VIA CROWN GEAR (DOUBLE CROWN FOR LARGE MACHINES)

Transmission between gearbox and roller is direct via pinion keyed onto the output shaft of the gear block and the crown gear welded onto the side of the roller (in large machines motion transmission to the roller is not direct, but takes place via chains and a shaft, connected to the two crown gears on the roller).



2.5 HOSE GUIDE MOVED BY WORM SCREW

"Fork" device sliding onto the worm screw (sliding bar) which arranges the PE hose evenly into the roller.

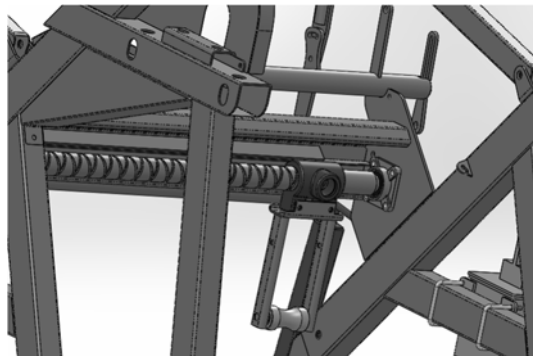

2.6 BYPASS TO ADJUST SPEED

Device placed near the turbine, on the water system which lets more or less water flow into the turbine, in order to adjust the PE hose reeling in speed.

**2.7 GLYCERINE PRESSURE GAUGE**

Device placed near the turbine, which lets you read the water pressure on the machine.

**2.8 DIGITAL METRE COUNTER**

Device that lets you read the PE hose reeling in speed.

**2.9 TURNTABLE AND HOLDER**

Devices that allow the base to rotate.

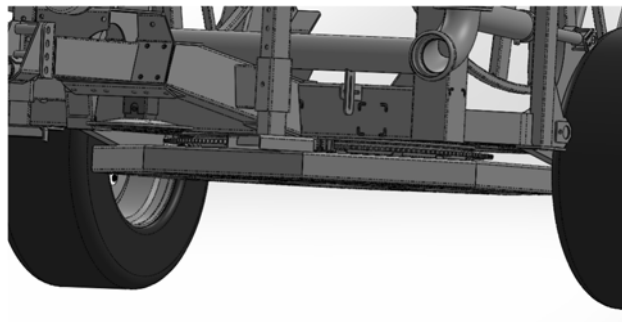

2.10 BASE ROTATION AND LIFTING/LOWERING OF THE TROLLEY LOADER, DRAWBAR LIFTING FOOT AND RIGHT AND LEFT WHEELS DRIVEN BY HYDRAULIC SYSTEM

Hydraulic system that allows the frame to rotate, the drawbar lifting foot to move, and the trolley loader wheels to prepare the machine for irrigation or towing.

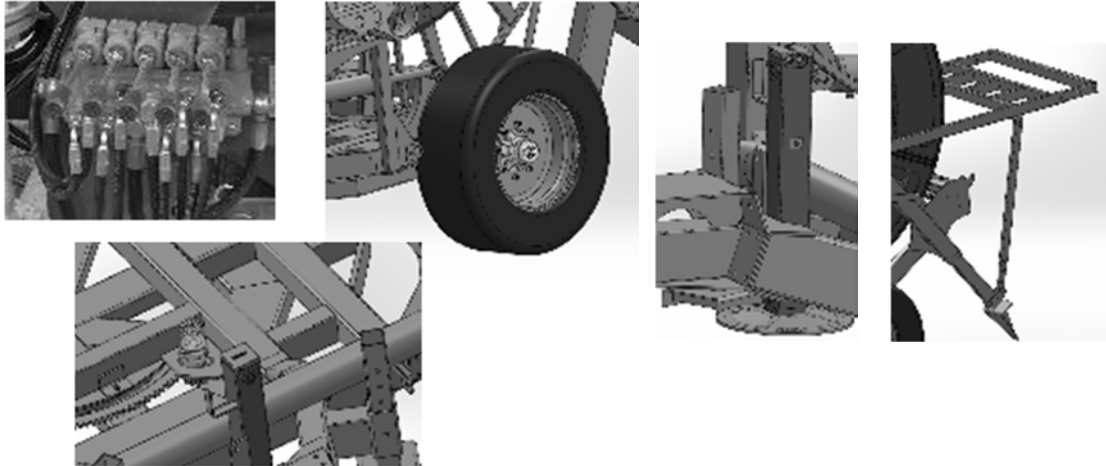

2.11 TROLLEY LOADER AND PARKING FEET

Devices to anchor the machine on the ground (different parking feet according to the models); device to load the irrigator trolley.

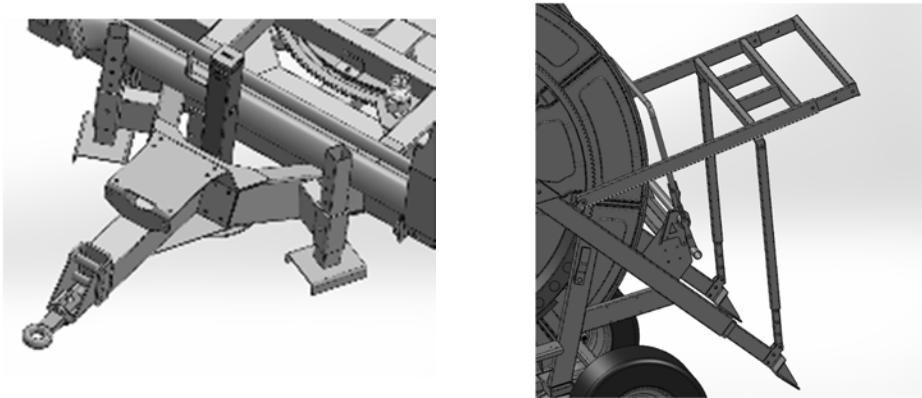

2.12 2 WHEEL FRAME (4 IN LARGE MACHINES) WITH WATER SYSTEM WITH DOUBLE INLET

The machine consists of a frame and a water system with two inlets, connected to the turbine and roller.

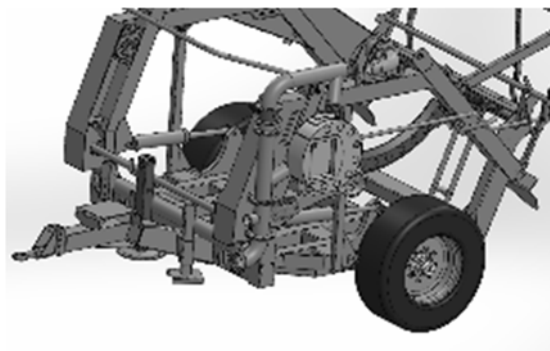

2.13 2-WHEEL IRRIGATOR TRAVELLER

2-wheel irrigator trolley connected to the PE hose (standard model).

**2.14 IRRIGATOR WITH SET OF NOZZLES**

Device fixed to the trolley that distributes the water evenly on the field.

**2.15 POLYETHYLENE HOSE**

PE hose.





TURBOCAR

Description Machine **2**

0.0 **7/22**

2	DESCRIPTION OF THE MACHINE
----------	-----------------------------------

PAR.	DESCRIPTION
3	Dimensions

3. DIMENSIONS

Weights and overall dimensions

STR.	TIPO	RUOTA	A	B	B1	C	D	E	F	G	KG
IG1.1	A	10.0/75.15.3-5F	2630	3070	2780	2460	2000	2560	3790	5800	2700 + 3000
	A	13.0/55.16-6F	2630	3070	2780	2530	2000	2560	3790	5800	
	B	10.0/75.15.3-5F	2680	3120	2830	2460	2000	2610	3790	5800	
	B	13.0/55.16-6F	2680	3120	2830	2530	2000	2610	3790	5800	
	C	10.0/75.15.3-5F	2740	3180	2890	2460	2000	2670	3790	5800	
	C	13.0/55.16-6F	2740	3180	2890	2530	2000	2670	3790	5800	
	D	10.0/75.15.3-5F	2680	3120	2830	2460	2000	2610	3790	5800	
	D	13.0/55.16-6F	2680	3120	2830	2530	2000	2610	3790	5800	
	E	10.0/75.15.3-5F	2740	3180	2890	2460	2000	2670	3790	5800	
	E	13.0/55.16-6F	2740	3180	2890	2530	2000	2670	3790	5800	
	F	10.0/75.15.3-5F	2680	3120	2830	2460	2000	2610	3790	5800	
	F	13.0/55.16-6F	2680	3120	2830	2530	2000	2610	3790	5800	
IG1.15	A	10.0/75.15.3-5F	2890	3330	3040	2460	2000	2770	3790	5800	2800 + 3250
	A	13.0/55.16-6F	2890	3330	3040	2530	2000	2770	3790	5800	
	B	10.0/75.15.3-5F	2890	3330	3040	2460	2000	2770	3790	5800	
	B	13.0/55.16-6F	2890	3330	3040	2530	2000	2770	3790	5800	
	C	10.0/75.15.3-5F	2890	3330	3040	2460	2000	2770	3790	5800	
C	13.0/55.16-6F	2890	3330	3040	2530	2000	2770	3790	5800		
IG1	A	10.0/75.15.3-6F	2870	3320	3010	2450	2220	2820	3950	5850	3350 + 4200
	A	11.5/80.15.3-6F	2870	3360	3010	2460	2220	2820	3950	5850	
	A	13.0/55.16-6F	2870	3330	3010	2570	2220	2820	3950	5850	
	A	400/60.15.3-6F	2870	3360	3010	2660	2220	2820	3950	5850	
	B	10.0/75.15.3-6F	2870	3320	3010	2450	2220	2820	3950	5850	
	B	11.5/80.15.3-6F	2870	3360	3010	2460	2220	2820	3950	5850	
	B	13.0/55.16-6F	2870	3330	3010	2570	2220	2820	3950	5850	
	B	400/60.15.3-6F	2870	3360	3010	2660	2220	2820	3950	5850	
	C	10.0/75.15.3-6F	2900	3350	3040	2450	2220	2850	3950	5850	
	C	11.5/80.15.3-6F	2900	3390	3040	2460	2220	2850	3950	5850	
	C	13.0/55.16-6F	2900	3360	3040	2570	2220	2850	3950	5850	
	C	400/60.15.3-6F	2900	3390	3040	2660	2220	2850	3950	5850	
	D	10.0/75.15.3-6F	3130	3590	3270	2450	2220	3020	4050	5950	
	D	11.5/80.15.3-6F	3130	3630	3270	2460	2220	3020	4050	5950	
	D	13.0/55.16-6F	3130	3600	3270	2570	2220	3020	4050	5950	
	D	400/60.15.3-6F	3130	3630	3270	2660	2220	3020	4050	5950	
	E	10.0/75.15.3-6F	3130	3590	3270	2450	2220	3020	4050	5950	
	E	11.5/80.15.3-6F	3130	3630	3270	2460	2220	3020	4050	5950	
	E	13.0/55.16-6F	3130	3600	3270	2570	2220	3020	4050	5950	
	E	400/60.15.3-6F	3130	3630	3270	2660	2220	3020	4050	5950	
	F	10.0/75.15.3-6F	3130	3590	3270	2450	2220	3020	4050	5950	
	F	11.5/80.15.3-6F	3130	3630	3270	2460	2220	3020	4050	5950	
	F	13.0/55.16-6F	3130	3600	3270	2570	2220	3020	4050	5950	
	F	400/60.15.3-6F	3130	3630	3270	2660	2220	3020	4050	5950	
	H	10.0/75.15.3-6F	3180	3640	3320	2450	2220	3070	4050	5950	
	H	11.5/80.15.3-6F	3180	3680	3320	2460	2220	3070	4050	5950	
	H	13.0/55.16-6F	3180	3650	3320	2570	2220	3070	4050	5950	
	H	400/60.15.3-6F	3180	3680	3320	2660	2220	3070	4050	5950	
	L	10.0/75.15.3-6F	3180	3640	3320	2450	2220	3070	4050	5950	
	L	11.5/80.15.3-6F	3180	3680	3320	2460	2220	3070	4050	5950	
	L	13.0/55.16-6F	3180	3650	3320	2570	2220	3070	4050	5950	
	L	400/60.15.3-6F	3180	3680	3320	2660	2220	3070	4050	5950	
M	10.0/75.15.3-6F	3180	3640	3320	2450	2220	3070	4050	5950		
M	11.5/80.15.3-6F	3180	3680	3320	2460	2220	3070	4050	5950		
M	13.0/55.16-6F	3180	3650	3320	2570	2220	3070	4050	5950		
M	400/60.15.3-6F	3180	3680	3320	2660	2220	3070	4050	5950		

STR.	TIPO	RUOTA	A	B	B1	C	D	E	F	G	KG	
IG15	A	11.5/80.15.3-6F	3340	3870	3480	2550	2400	3140	4110	6050	5000 + 5500	
	A	400/60.15.3-6F	3340	3870	3480	2760	2400	3140	4110	6050		
	A	13.0/65.18-6F	3340	3900	3480	2690	2400	3140	4110	6050		
	B	11.5/80.15.3-6F	3340	3870	3480	2550	2400	3140	4110	6050		
	B	400/60.15.3-6F	3340	3870	3480	2760	2400	3140	4110	6050		
	B	13.0/65.18-6F	3340	3900	3480	2690	2400	3140	4110	6050		
	C	11.5/80.15.3-6F	3340	3870	3480	2550	2400	3140	4110	6050		
	C	400/60.15.3-6F	3340	3870	3480	2760	2400	3140	4110	6050		
	C	13.0/65.18-6F	3340	3900	3480	2690	2400	3140	4110	6050		
	A	11.5/80.15.3-6F	3330	3770	3480	2600	2550	3180	4320	6300		5700 + 5800
	A	13.0/65.18-6F	3330	3790	3480	2680	2550	3180	4320	6300		
	A	385/65.22.5-6F	3330	3870	3480	2800	2550	3180	4320	6300		
A	500/50.17-6F	3330	3810	3480	3020	2550	3180	4320	6300			
B	11.5/80.15.3-6F	3330	3770	3480	2600	2550	3180	4320	6300			
B	13.0/65.18-6F	3330	3790	3480	2680	2550	3180	4320	6300			
B	385/65.22.5-6F	3330	3870	3480	2800	2550	3180	4320	6300			
B	500/50.17-6F	3330	3810	3480	3020	2550	3180	4320	6300			
C	11.5/80.15.3-6F	3330	3770	3480	2600	2550	3180	4320	6300			
C	13.0/65.18-6F	3330	3790	3480	2680	2550	3180	4320	6300			
C	385/65.22.5-6F	3330	3870	3480	2800	2550	3180	4320	6300			
C	500/50.17-6F	3330	3810	3480	3020	2550	3180	4320	6300			
IG3	A	385/65.22.5-6F	3580	4130	3730	2800	2550	3400	4320	6400	7450 + 7550	
	A	500/50.17-6F	3580	4070	3730	3020	2550	3400	4320	6400		
	B	385/65.22.5-6F	3580	4130	3730	2800	2550	3400	4320	6400		
	B	500/50.17-6F	3580	4070	3730	3020	2550	3400	4320	6400		
	C	385/65.22.5-6F	3580	4130	3730	2800	2550	3400	4320	6400		
	C	500/50.17-6F	3580	4070	3730	3020	2550	3400	4320	6400		

Le presenti misure possono essere soggette a modifiche; Idrofoglia Srl si riserva la facoltà di poterle variare senza preavviso / The dimensions can change; Idrofoglia Srl reserves the right to modify without notice

DESCRIPTION OF THE MACHINE

STR.	TIPO	RUOTA	A	B	B1	C	D	E	F	G	KG
IG2 (4 ruote)	A	10.0/75.15.3-6F	3330	3810	3480	3000	2550	3180	4320	6300	5700 + 5900
	A	11.5/80.15.3-6F	3330	3850	3480	3000	2550	3180	4320	6300	
	A	13.0/55.16-6F	3330	3810	3480	3110	2550	3180	4320	6300	
	A	13.0/65.18-6F	3330	3880	3480	3090	2550	3180	4320	6300	
	A	400/60.15.5-6F	3330	3840	3480	3200	2550	3180	4320	6300	
	B	10.0/75.15.3-6F	3330	3810	3480	3000	2550	3180	4320	6300	
	B	11.5/80.15.3-6F	3330	3850	3480	3000	2550	3180	4320	6300	
	B	13.0/55.16-6F	3330	3810	3480	3110	2550	3180	4320	6300	
	B	13.0/65.18-6F	3330	3880	3480	3090	2550	3180	4320	6300	
	B	400/60.15.5-6F	3330	3840	3480	3200	2550	3180	4320	6300	
	C	10.0/75.15.3-6F	3330	3810	3480	3000	2550	3180	4320	6300	
	C	11.5/80.15.3-6F	3330	3850	3480	3000	2550	3180	4320	6300	
IG3 (4 ruote)	A	11.5/80.15.3-6F	3580	4100	3730	3000	2550	3400	4320	6400	7500 + 7600
	A	13.0/55.16-6F	3580	4060	3730	3110	2550	3400	4320	6400	
	A	13.0/65.18-6F	3580	4130	3730	3090	2550	3400	4320	6400	
	A	400/60.15.5-6F	3580	4090	3730	3200	2550	3400	4320	6400	
	B	11.5/80.15.3-6F	3580	4100	3730	3000	2550	3400	4320	6400	
	B	13.0/55.16-6F	3580	4060	3730	3110	2550	3400	4320	6400	
	B	13.0/65.18-6F	3580	4130	3730	3090	2550	3400	4320	6400	
	B	400/60.15.5-6F	3580	4090	3730	3200	2550	3400	4320	6400	
	C	11.5/80.15.3-6F	3580	4100	3730	3000	2550	3400	4320	6400	
	C	13.0/55.16-6F	3580	4060	3730	3110	2550	3400	4320	6400	
	C	13.0/65.18-6F	3580	4130	3730	3090	2550	3400	4320	6400	
	C	400/60.15.5-6F	3580	4090	3730	3200	2550	3400	4320	6400	

STR.	TIPO	RUOTA	A	B	B1	C	D	E	F	G	KG
IG4 (4 ruote)	A	11.5/80.15.3-6F	3580	4100	3730	2900	2750	3700	5300	7100	9300 + 9800
	A	13.0/65.18-6F	3580	4120	3730	2990	2750	3700	5300	7100	
	A	15.0/55.17-8F	3580	4100	3730	3130	2750	3700	5300	7100	
	A	500/50.17-6F	3580	4140	3730	3330	2750	3700	5300	7100	
	B	11.5/80.15.3-6F	3580	4100	3730	2900	2750	3700	5300	7100	
	B	13.0/65.18-6F	3580	4120	3730	2990	2750	3700	5300	7100	
	B	15.0/55.17-8F	3580	4100	3730	3130	2750	3700	5300	7100	
	B	500/50.17-6F	3580	4140	3730	3330	2750	3700	5300	7100	
	C	11.5/80.15.3-6F	3580	4100	3730	2900	2750	3700	5300	7100	
	C	13.0/65.18-6F	3580	4120	3730	2990	2750	3700	5300	7100	
	C	15.0/55.17-8F	3580	4100	3730	3130	2750	3700	5300	7100	
	C	500/50.17-6F	3580	4140	3730	3330	2750	3700	5300	7100	
IG5 (4 ruote)	A	13.0/65.18-6F	3900	4440	4050	2990	2750	3780	5300	7100	10500 + 10800
	A	15.0/55.17-8F	3900	4420	4050	3130	2750	3780	5300	7100	
	A	19.0/45.17-8F	3900	4430	4050	3290	2750	3780	5300	7100	
	A	500/50.17-6F	3900	4460	4050	3330	2750	3780	5300	7100	
	B	13.0/65.18-6F	3900	4440	4050	2990	2750	3780	5300	7100	
	B	15.0/55.17-8F	3900	4420	4050	3130	2750	3780	5300	7100	
	B	19.0/45.17-8F	3900	4430	4050	3290	2750	3780	5300	7100	
	B	500/50.17-6F	3900	4460	4050	3330	2750	3780	5300	7100	
	C	13.0/65.18-6F	3900	4440	4050	2990	2750	3780	5300	7100	
	C	15.0/55.17-8F	3900	4420	4050	3130	2750	3780	5300	7100	
	C	19.0/45.17-8F	3900	4430	4050	3290	2750	3780	5300	7100	
	C	500/50.17-6F	3900	4460	4050	3330	2750	3780	5300	7100	

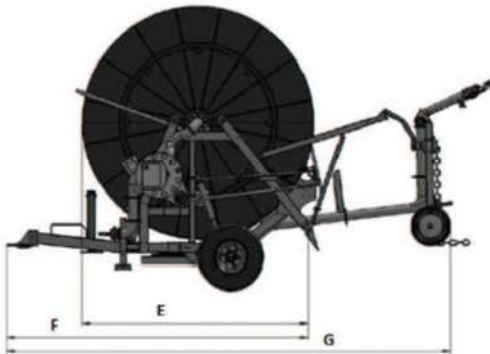

B = ALTEZZA CON MACCHINA SULLE RUOTE
Hauteur de la machine sur les roues / Height
of the machine on the wheels / Höhe der
Maschine auf Räder / Altura con la máquina
sobre las ruedas

B1 = ALTEZZA CON MACCHINA SUL TERRENO
Hauteur de la machine sur le terrain / Height
of the machine on the ground / Höhe der
Maschine auf Boden / Altura con la máquina
sobre el terreno

2	DESCRIPTION OF THE MACHINE
----------	-----------------------------------

PAR.	DESCRIPTION
4	Environmental conditions

4. ENVIRONMENTAL CONDITIONS

The machine does not require special environmental conditions and will be installed outdoors.

The operations for placing the machine must always be performed assuring the stability of the irrigator during its operation.

During machine placement on sloping ground, perform the manoeuvre with assistance from another person.

2	DESCRIPTION OF THE MACHINE
----------	-----------------------------------

PAR.	DESCRIPTION
5	Sound emissions

5. SOUND EMISSIONS

Sound pressure level:

74 dB (A) at 1 m

70 dB (A) at 2 m

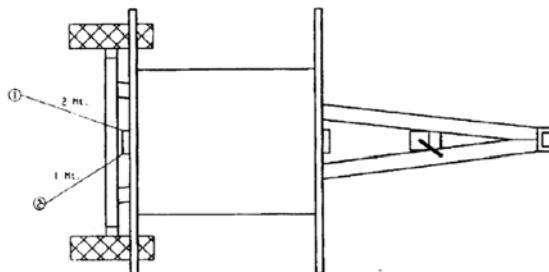

DESCRIPTION OF THE MACHINE



TURBOCAR

Description
Machine **2**

0.0 **11/22**

ø tubo mm	ø boccaaglio mm	Pressione macchina Atm.										Press. Irrig. Atm.	Cilindrata M ³ .	Raccolta Irrigata M ³ .	Portata l/min.	Superficie Irrigata Ha.										Pioggia		
		200	250	300	350	400	450	500	550	600	650					200	250	300	350	400	450	500	550	600	650	10 m/h	30 m/h	60 m/h
100	26	4,5	4,7	4,9	5,2	5,6	5,9	6,2	6,6	7,1	7,4	3,0	42,0	71,4	732	1,56	1,90	2,23	2,57	2,91	3,25	3,59	3,93	4,27	4,61	53,6	17,9	10,7
		5,8	6,1	6,4	6,7	7,2	7,6	8,0	8,6	9,2	9,6	4,0	47,0	79,9	845	1,77	2,12	2,53	2,91	3,29	3,67	4,05	4,43	4,80	5,18	54,5	18,2	10,9
	28	6,1	6,5	7,0	7,4	8,0	8,6	9,1	9,8	10,6	11,1	4,0	51,0	86,7	980	1,94	2,35	2,77	3,18	3,59	4,00	4,41	4,83	5,24	5,65	57,5	19,2	11,5
		7,5	8,0	8,5	9,1	9,8	10,5	11,2	12,0	13,0	13,6	5,0	56,0	95,2	1095	2,12	2,62	3,07	3,52	3,97	4,43	4,88	5,33	5,78	6,23	57,7	19,2	11,5
	30	8,1	8,7	9,5	10,1	11,0	11,9	12,8	13,9	15,1	15,9	5,0	57,0	96,9	1260	2,21	2,67	3,13	3,59	4,05	4,51	4,97	5,43	5,89	6,35	65,0	21,7	13,0
		8,8	9,5	10,2	11,0	12,0	13,0	14,0	15,1	16,5	17,3	5,5	58,5	99,5	1320	2,28	2,75	3,22	3,69	4,17	4,64	5,11	5,58	6,06	6,53	66,1	22,0	13,2
110	28	4,3	4,5	4,7	4,9	5,2	5,5	5,9	6,3	6,6	6,9	3,0	44,0	74,8	848	1,64	2,00	2,35	2,71	3,06	3,42	3,77	4,13	4,48	4,84	58,9	19,6	11,8
		5,5	5,8	6,0	6,3	6,7	7,1	7,6	8,1	8,5	8,9	4,0	51,0	86,7	980	1,94	2,35	2,77	3,18	3,59	4,00	4,41	4,83	5,24	5,65	57,5	19,2	11,5
	30	5,8	6,1	6,4	6,8	7,3	7,9	8,5	9,1	9,7	10,1	4,0	52,0	88,4	1127	1,99	2,41	2,83	3,25	3,67	4,09	4,51	4,93	5,35	5,77	64,7	21,6	12,9
		7,1	7,5	7,9	8,3	8,9	9,7	10,4	11,2	11,8	12,4	5,0	57,0	96,9	1260	2,21	2,67	3,13	3,59	4,05	4,51	4,97	5,43	5,89	6,35	65,0	21,7	13,0
	32	7,5	8,0	8,5	9,1	9,8	10,7	11,6	12,7	13,5	14,2	5,0	58,0	98,6	1432	2,25	2,72	3,19	3,66	4,13	4,60	5,07	5,53	6,00	6,47	72,4	24,1	14,5
		7,7	8,2	8,6	9,1	9,8	10,6	11,4	12,3	13,0	13,6	5,5	60,0	102,0	1330	2,35	2,83	3,32	3,80	4,28	4,76	5,25	5,74	6,22	6,71	64,6	21,5	12,9
125	32	5,7	5,9	6,1	6,5	6,8	7,2	7,6	8,0	8,5	8,9	4,0	54,0	91,8	1282	2,51	2,95	3,38	3,82	4,26	4,69	5,13	5,56	6,00	6,44	72,7	24,2	14,5
		6,9	7,2	7,5	7,9	8,3	8,8	9,2	9,8	10,3	10,8	5,0	58,0	98,6	1432	2,72	3,19	3,66	4,13	4,60	5,07	5,53	6,00	6,47	6,94	74,9	25,0	15,0
	36	7,7	8,1	8,6	9,2	9,7	10,5	11,2	12,0	12,9	13,7	5,0	61,0	103,7	1613	2,88	3,38	3,87	4,36	4,86	5,35	5,84	6,33	6,83	7,32	89,6	29,9	17,9
		9,1	9,6	10,1	10,8	11,5	12,4	13,3	14,2	15,3	16,2	6,0	66,0	112,2	1988	3,16	3,69	4,22	4,76	5,29	5,82	6,36	6,89	7,42	7,96	89,7	29,9	17,9
	38	8,2	8,7	9,2	10,0	10,7	11,6	12,5	13,5	14,5	15,5	5,0	63,0	107,1	2022	2,99	3,50	4,01	4,52	5,03	5,54	6,05	6,55	7,06	7,57	96,2	32,1	19,2
		9,6	10,3	10,9	11,8	12,6	13,7	14,7	15,9	17,2	18,3	6,0	68,0	115,6	2215	3,27	3,82	4,37	4,92	5,47	6,02	6,56	7,11	7,66	8,21	96,5	32,2	19,3
135	34	6,9	7,2	7,6	7,9	8,3	8,6	8,9				5,0	59,0	100,3	1618	3,25	3,73	4,21	4,68	5,16	5,64	6,11			89,4	23,1	13,9	
		8,2	8,5	8,9	9,3	9,8	10,1	10,5				6,0	64,0	108,8	1773	3,57	4,08	4,60	5,12	5,63	6,15	6,67			89,4	23,1	13,9	
	36	7,2	7,6	8,0	8,4	8,9	9,3	9,6				5,0	61,0	103,7	1813	3,38	3,87	4,36	4,86	5,35	5,84	6,33			74,9	25,0	15,0	
		8,6	9,0	9,5	9,9	10,5	11,0	11,4				6,0	66,0	112,2	1988	3,69	4,22	4,76	5,29	5,82	6,36	6,89			75,1	25,0	15,0	
	38	7,6	8,1	8,6	9,0	9,7	10,1	10,5				5,0	63,0	107,1	2022	3,50	4,01	4,52	5,03	5,54	6,05	6,55			80,5	26,8	16,1	
		9,0	9,5	10,1	10,7	11,4	11,9	12,5				6,0	68,0	115,6	2215	3,82	4,37	4,92	5,47	6,02	6,56	7,11			80,9	27,0	16,2	
140	34	6,7	6,9	7,2	7,5	7,8	8,1	8,4	8,7	9,0		5,0	59,0	100,3	1618	3,25	3,73	4,21	4,68	5,16	5,64	6,11	6,59	7,06	83,3	27,8	16,7	
		7,9	8,2	8,5	8,8	9,2	9,5	9,9	10,3	10,6		6,0	64,0	108,8	1773	3,57	4,08	4,60	5,12	5,63	6,15	6,67	7,18	7,70	83,3	27,8	16,7	
	36	6,9	7,2	7,6	7,9	8,3	8,6	9,0	9,4	9,8		5,0	61,0	103,7	1813	3,38	3,87	4,36	4,86	5,35	5,84	6,33	6,83	7,32	89,9	30,0	18,0	
		8,2	8,6	9,0	9,3	9,8	10,2	10,7	11,1	11,6		6,0	66,0	112,2	1988	3,69	4,22	4,76	5,29	5,82	6,36	6,89	7,42	7,96	90,2	30,1	18,0	
	38	7,3	7,6	8,0	8,4	8,9	9,3	9,8	10,3	10,7		5,0	63,0	107,1	2022	3,50	4,01	4,52	5,03	5,54	6,05	6,55	7,06	7,57	96,6	32,2	19,3	
		8,6	9,0	9,5	9,9	10,5	11,0	11,6	12,1	12,7		6,0	68,0	115,6	2215	3,82	4,37	4,92	5,47	6,02	6,56	7,11	7,66	8,21	97,1	32,4	19,4	
150	36	6,5	6,7	7,0	7,2	7,5	7,7	7,9				5,0	61,0	103,7	1813	3,38	3,87	4,36	4,86	5,35	5,84	6,33			89,9	30,0	18,0	
		7,7	8,0	8,2	8,5	8,8	9,1	9,4				6,0	66,0	112,2	1988	3,69	4,22	4,76	5,29	5,82	6,36	6,89			90,2	30,1	18,0	
	38	6,7	7,0	7,3	7,6	7,9	8,2	8,5				5,0	63,0	107,1	2022	3,50	4,01	4,52	5,03	5,54	6,05	6,55			96,6	32,2	19,3	
		8,0	8,3	8,6	9,0	9,3	9,6	10,0				6,0	68,0	115,6	2215	3,82	4,37	4,92	5,47	6,02	6,56	7,11			97,1	32,4	19,4	
	40	8,3	8,6	9,0	9,5	9,9	10,3	10,7				6,0	69,0	117,3	2455	3,88	4,44	5,00	5,55	6,11	6,67	7,23			105,8	35,3	21,2	
		8,9	9,3	9,7	10,2	10,6	11,1	11,5				6,5	71,0	120,7	2552	4,01	4,59	5,16	5,73	6,31	6,88	7,45			106,5	35,5	21,3	
160	38	6,6	6,8	7,0	7,3	7,5						5,0	65,0	110,5	2022	3,63	4,15	4,68	5,20	5,73					93,3	31,1	18,7	
		7,7	8,0	8,3	8,6	8,9						6,0	69,5	118,2	2215	3,92	4,48	5,04	5,60	6,16					94,7	31,6	18,9	
	40	8,0	8,4	8,7	9,0	9,3						6,0	71,0	120,7	2455	4,01	4,59	5,16	5,73	6,31					102,4	34,1	20,5	
		9,2	9,6	10,0	10,4	10,7						7,0	76,0	129,2	2648	4,34	4,95	5,56	6,18	6,79					102,2	34,1	20,4	
	42	8,3	8,7	9,1	9,5	9,9						6,0	72,0	122,4	2705	4,08	4,66	5,24	5,82	6,40					111,1	37,0	22,2	
		9,6	10,0	10,5	10,9	11,4						7,0	77,5	131,8	2918	4,44	5,06	5,69	6,31	6,94					110,1	36,7	22,0	

DESCRIPTION OF THE MACHINE



TURBOCAR

Description
Machine

2

0.0

12/22

2	DESCRIPTION OF THE MACHINE
---	-----------------------------------

PAR.	DESCRIPTION
7	Tools

7. TOOLS

The machine is not supplied with any tools. Only if a control unit is installed, a manual lever is provided to be fitted in an emergency on the bypass valve, in the event problems should occur with the control unit/electric motor etc. The lever makes it possible to continue working.

2	DESCRIPTION OF THE MACHINE
---	-----------------------------------

PAR.	DESCRIPTION
8	Panels and buttons

8. PANELS AND BUTTONS

A digital metre counter is supplied with the machine to read the PE hose reeling in speed.
As an optional feature the machine may be supplied with control unit for adjusting the PE hose reeling in speed.

DESCRIPTION OF THE MACHINE

2	DESCRIPTION OF THE MACHINE
---	-----------------------------------

PAR.	DESCRIPTION
9	Standard supply

9. STANDARD SUPPLY

The Machine is supplied with complete outfitting for commissioning.

Standard supply:

- turbine;
- gearbox with gears in oil bath;
- safety devices for PTO and reeling in out of stowed position;
- motion drive to the roller via crown gear (double crown for large machines);
- hose guide moved by worm screw;
- bypass to adjust speed;
- glycerine pressure gauge;
- digital metre counter;
- turntable and holder;
- base rotation and lifting/lowering of the trolley loader, of the drawbar lifting foot and of the right and left wheels, actuated by hydraulic system;
- trolley loader and parking feet;
- 2-wheel frame (4 for large machines) with water system with double inlet;
- 2-wheel irrigator traveller;
- irrigator with set of nozzles;
- polyethylene hose;
- safety guards according to EC standards;
- use and maintenance manual;
- CE certificate;
- warranty card;

2	DESCRIPTION OF THE MACHINE
PAR.	DESCRIPTION
10	Accessories

10. ACCESSORIES

Below is a list of accessories that may be fitted on the various turbocar models:

- **FLEXIBLE HOSE WITH JOINTS:** hose connecting the machine and the water supply line.



- **REEL WITH FLAT HOSE ON BOARD THE MACHINE:** device used to reel in the flat hose.

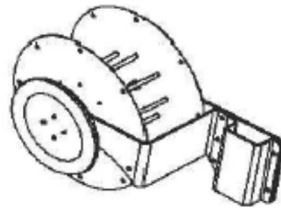

- **CONICAL FILTER:** filter for filtering the water flowing into the machine.



- **WATER VALVE ON INLET OR DRAIN:** device that closes the water inlet in the machine at the end of irrigation (inlet or over-pressure) or opens an additional duct to drain the water (discharge or negative pressure).

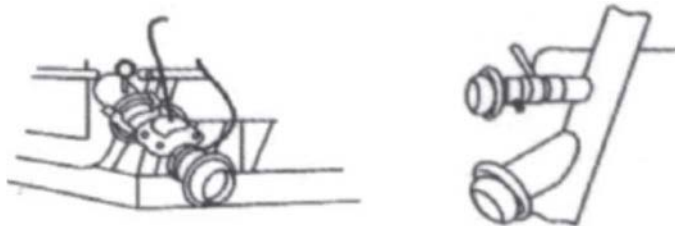

- **INLET SOLENOID VALVE FOR SLOW CLOSING**: device that closes water inlet into the machine at the end of irrigation. It behaves like the inlet water valve but closure takes place progressively in about 3 minutes.

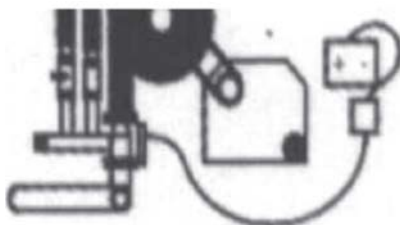

- **CONTROL UNIT B2, PRO35, PRO45, IRRIMOP, NORTOFT**: unit to automatically regulate the hose reeling in speed.



- **REMOTE GSM CONTROL**: system to be combined with the control units to know irrigation status, end of irrigation and any problems that may arise during the irrigation process.



- **PRESSURE SWITCH**: device to stop the machine, in the absence of water and to restart the cycle when water is available again from the time it was suspended.

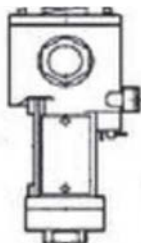

- **FLASHING LIGHT**: visual device for end of paying out and to warn of any problems that may arise during the irrigation process.



- **SOLAR PANEL**: device to keep the battery charged.

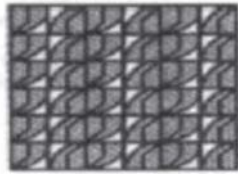

- **COMPRESSOR**: device to partially empty the water inside the PE hose.



- **HYDRAULIC ACCESSORIES FOR MOVEMENT**

- distributor with quick couplings to load the trolley, place the feet or superstructure slewing, wheel lifting; hydraulic movements may also be actuated individually by directly connecting the quick couplings (without distributor);
- pump to be applied to the quick couplings to control the hydraulic system.

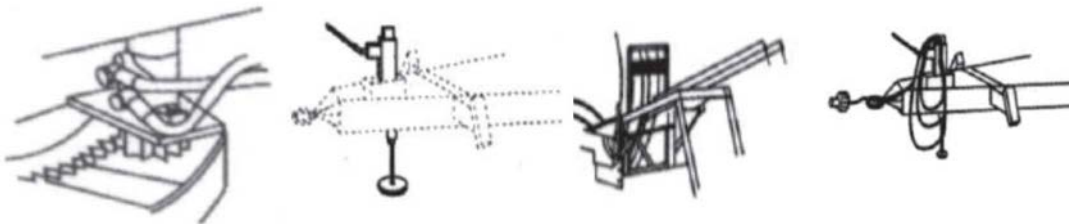

- **REMOTE CONTROL**: device that replaces the distributor, to actuate a hydraulic movement of the machine, by means of buttons or remote control.

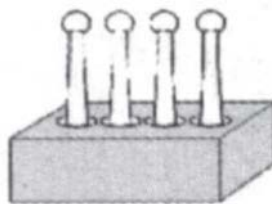

- **ADAPTATION WITH A VARIETY OF DRAWBAR EYES**: double flat, weld-on type, tapered, elongated.



- **LIGHT BAR ADAPTATION:** adjustable, adjustable and tipping.

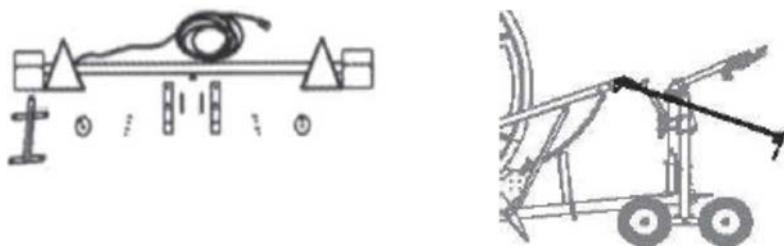

- **FRAME ON 4 ROCKER WHEELS:** machine with 4 wheels instead of 2.

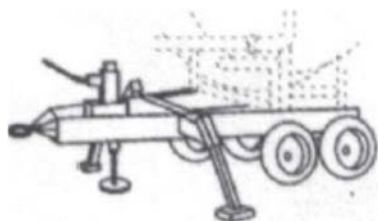

- **DOUBLE CROWN GEAR FOR REELING IN:** roller drive with double crown gear.



- **TOOL BOX ON FRAME:** tool box on the frame.

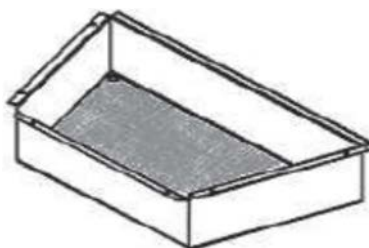

- **SUPPLEMENTARY INLET FOR OTHER LIQUIDS:** secondary inlet with turbine override.



- **DIESEL ENGINE (PULL OR ELECTRIC START) REPLACING THE TURBINE FOR BELT OR HYDRAULIC REELING IN:** motor used to reel in the PE hose (possibly also for hydraulic controls) to replace the turbine.

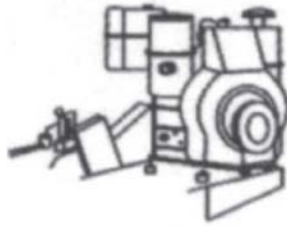

- **PETROL ENGINE WITH PULL START FOR HYDRAULIC CONTROLS:** engine used for the hydraulic movements of the machine.

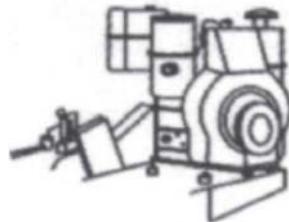

- **HYDROSTATIC VALVE:** if the machine does not have the control unit it is possible to install a device to turn the engine off in the event the water supply to the machine should fail.



- **PLASCOAT TURBINE PAINTING:** turbine painting for foul wastewater.



- **LITRE COUNTER:** device that measures the water flow rate in the machine.

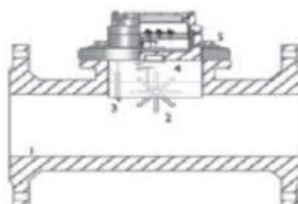

- **HOT-DIP GALVANISED FRAME OR ROLLER**

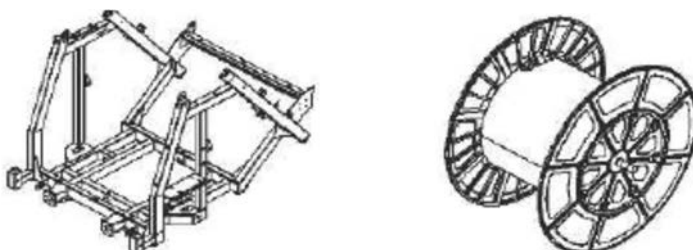

- **ROAD APPROVAL**

- **HP TROLLEY**: trolley for high pressure adjustable up to 330 m.

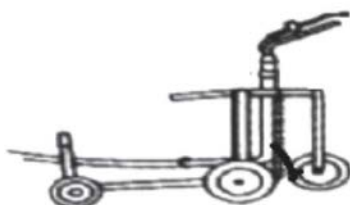

- **OFFSET TROLLEY**: trolley with hose in axis with the right wheel or with the left wheel of the trolley.



- **CORN TYPE TROLLEY**: higher than standard trolley.



- **TROLLEY JOINT**: joint to be applied between hose and trolley.

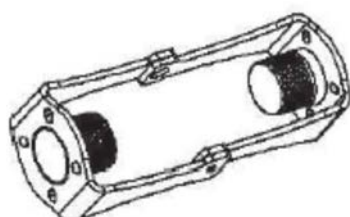

- **POSSIBLE TROLLEY ADAPTATIONS**

- swivel wheels;
- cast iron wheels;
- direction discs;
- pneumatic oversized trolley nose wheel;
- pneumatic wheels.

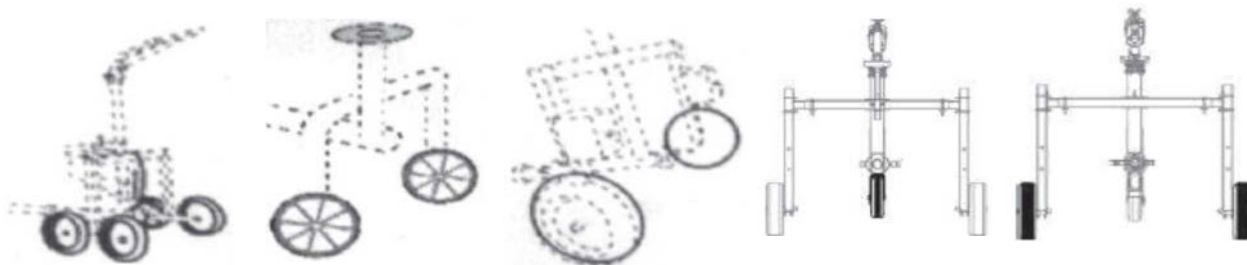

- **TROLLEY EXTENSION**: device to lift the irrigator into the trolley.



- **QUICK IRRIGATOR RELEASE**: device to quickly disconnect the irrigator from the trolley.



- **SUPPLEMENTARY VALVE ON THE TROLLEY**: it is possible to install a closing valve under the irrigator on the trolley.

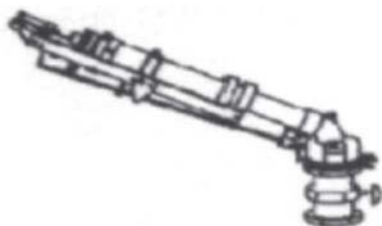

- **IRON OR CONCRETE BALLAST:** iron or concrete weights to be applied to the trolley.

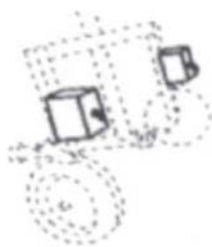

- **WATER BALLAST TANK:** tank to be filled with water and applied to the trolley to act as ballast.

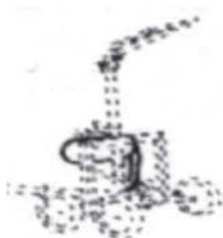

- **RIGID DRAWBAR ON THE TROLLEY:** trolley towing drawbar in place of the standard chain.



- **HEIGHT AND WIDTH ADJUSTABLE LEGS:** it is possible to manually adjust the height and width of the trolley with mechanical feet.

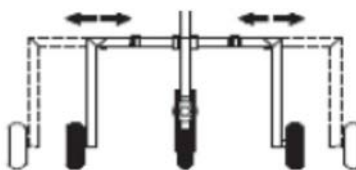
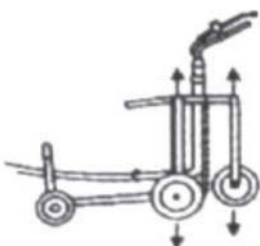

- **SMALL IRRIGATOR UNDER THE IRRIGATOR:** second small irrigator to be installed on the trolley, under the main one, which may be operated by opening a ball valve.

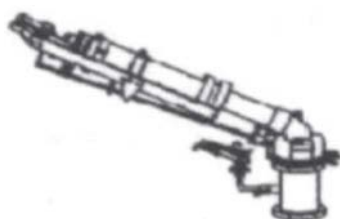

- **OVERTREE KIT:** kit to lift the irrigator.



- **OVERTREE KIT:** slide with adjustable sprinklers.

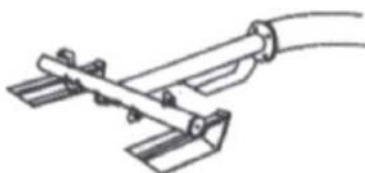

- **SECOND IRRIGATOR KIT MOUNTED ON MACHINE FRAME:** second small irrigator, actuated by manually opening a ball valve (if there is a control unit it can be controlled automatically, through an electric motor installed on the ball valve).



3	SAFETY
PAR.	DESCRIPTION
1	General warnings

1. GENERAL SAFETY WARNINGS



Before making the Machine operational, carefully read the instructions in this Manual and carefully follow the indications herein.

The manufacturer has strived to ensure this Machine has been designed to make it INTRINSICALLY SAFE to the extent possible.

They have also equipped it with all safety guards and devices deemed necessary and, finally, has provided sufficient information so it is used safely and correctly.

To this end, the following information is provided in every chapter, when required, for every man-machine interaction:

- machine status;
- residual hazards;
- required or recommended personal protection equipment;
- prevention of human errors;
- prohibitions/obligations concerning reasonably foreseeable incorrect behaviour.



This information must be strictly complied with.

The User may appropriately integrate the information provided by the manufacturer with additional work instructions, obviously not in contrast with the provisions of this Instruction Manual, to contribute to safe use of the Machine.

When required, the Manual specifies additional recommendations under the user's responsibility on prevention measures, personal protection equipment, information for preventing human errors and prohibitions concerning reasonably foreseeable forbidden behaviour.

However, it is indispensable to thoroughly comply with the following indications:

- it is strictly forbidden to inhibit the safety devices installed on the Machine;
- operations with reduced safety devices must be carried out strictly complying with the indications provided in the relevant descriptions;
- after an operation with reduced safety devices the Machine's condition with active guards must be restored as soon as possible;
- do not modify any part of the Machine for any reason; in the event of malfunction, due to failure to comply with the above, the manufacturer shall not be liable for the consequences. It is recommended to request any modifications directly from the manufacturer;
- it is strictly forbidden to wear scarves, ties and loose clothing in general;
- no more than one person may operate simultaneously on the machine;
- keep children and unauthorised persons away from the machine.

**IMPORTANT!**

The manufacturer disclaims any liability for damage caused by the Machine to persons, animals or property in the event of:

- use of the Machine or intrusion in the area of operations by personnel not adequately trained;
- misuse of the machine;
- supply and hydraulics defects;
- incorrect installation;
- deficiencies in the scheduled maintenance;
- unauthorised modifications or operations;
- use of non original spare parts or non specific for the model;
- total or partial failure to comply with the instructions;
- use against specific national regulations;
- natural disasters and exceptional events.

General requirements

Movable elements must always be used according to the manufacturer's requirements, as indicated in this Manual, which must always be available in the workplace.

All safety equipment fitted on movable elements to prevent accidents and assure safety cannot be modified or removed, but must be adequately maintained.

The User must promptly inform the employer or their direct superior of any defects or faults observed in the movable elements.

Checks and inspections

Checks must be performed as indicated in the relevant chapter of this booklet.

If worn or defective parts are not promptly replaced, the manufacturer disclaims any liability for the damage from any accidents that might derive.

The checks must be performed by an experienced person. They must be visual and functional, with the purpose of assuring machine safety. They include:

- check of all load-bearing structures, which must show no crack, breakage, damage, deformation, corrosion, wear or alteration compared to the original features;
- check of all mechanical parts;
- check of all safety devices installed on the Machine;
- check of all connections with pins and screws;
- functional inspection of the Machine;
- inspection of the Machine's condition;
- check of the tightness and efficiency of the Hydraulic system.

The results of this check must be entered in an appropriate card.

**ATTENTION!**

If faults are observed, they must be removed before starting the Machine up again, and the expert who performs the check must note down on the card the successful repair, thus approving the Machine for use.

If they find any dangerous cracks or abnormalities, the person who performs the check must promptly inform the Machine's manufacturer.

Put the Machine out of order if any operation abnormalities occur and perform the appropriate checks or repairs.

Ensure there are no objects between the Machine parts.

After any maintenance operation, ensure no object remains between the moving parts.

In order to assure the utmost safety when moving the Machine, however, it is FORBIDDEN:

- tamper with any part of the Machine;
- leave movable elements unattended;
- use the Machine when it is operable but not entirely efficient;
- modify the Machine to change the originally intended use, without express authorisation by the Manufacturer or without taking on the complete liability set forth by the Machinery Directive.

1.1 ATTENTION



DO NOT operate the machine if there are any children or unauthorised people, ensure that in no case may children access the machine and use it.

PAY ATTENTION to the irrigator. Pressurised water is sprayed from the irrigator, which may cause severe harm to people and damage to property.

PAY ATTENTION during transport MAX TOWING SPEED 10 Km/h (if the Machine is approved, the limit specified on the registration paper/technical annex applies). In the event of uneven terrain, further reduce speed, in order to prevent hazardous imbalance of the machine (according to the country, take into account that only approved machines may circulate on public roads).

NEVER ACT on machine parts while it is operating.
Stop the machine and disconnect the water inlet hose from the source.

PAY ATTENTION before disconnecting the hose. When the machine is equipped with closing valve, the hose remains pressurised at the end of work.

DO NOT disconnect the hose before discharging the pressure.



PAY ATTENTION TO ELECTRICITY SOURCES

The water spray of the irrigator must never come into contact with electricity lines or other power sources. Do not place parts of the machine or irrigation hoses in contact with electricity sources.

3	SAFETY
PAR.	DESCRIPTION
2	Intended use

2. INTENDED USE

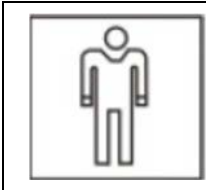

Machine operator: operator authorised to use the machine (strictly following the manufacturer's instructions) in compliance with the laws in force in the machine user's country.

The machine has been solely designed and constructed for irrigation of agricultural plots with any kind of crop, parks, sport facilities and hothouses.

The turbocar is designed to assure safe and reliable operation provided the instructions are followed. Carefully read the Use and Maintenance Manual before starting up the turbocar. Otherwise, personal injury or damage to the equipment may occur.

Always perform a preliminary check before starting up the turbocar. This may prevent accidents or damage to the equipment.

Place the turbocar on a flat surface.

Learn to stop the turbocar quickly and understand operation of all the controls. Do not allow unauthorised persons near the turbocar.

It is not permitted to perform tampering, modifications and repairs (those not permitted to the operator) on the machine or parts thereof which might affect its operation or safety conditions.

The operator must wear: protective helmet, protective gloves, safety shoes

It is forbidden to wear scarves, ties and loose clothing in general.

No more than one person may operate simultaneously on the machine.

Keep children and unauthorised persons away from the machine.



Using products/materials other than specified by the Manufacturer, which might cause damage to the machine and dangerous situations for the operator or the people close to the Machine, is considered incorrect and misuse.

SAFETY

3	SAFETY
----------	---------------

PAR.	DESCRIPTION
3	Contraindications for use

3. CONTRAINDICATIONS FOR USE

The turbocar must not be used:

- for uses other than set out under 3.2, for other uses or not mentioned in this manual;
- with circumvented safety devices or not working;
- in explosive, corrosive atmosphere or with high concentration of powders or oily substances suspended in the air;
- in atmosphere at risk of fire;
- with mechanical means that bypass fixtures/parts of the Machine.

3	SAFETY
----------	---------------

PAR.	DESCRIPTION
4	Hazardous areas

4. HAZARDOUS AREAS

- PTO on gearbox.
- Transmission between gearbox and crown gear on roller (chain and direct drive, between crown gear/drive shaft/gearbox pinion if the machine has two crown gears on the roller).
- Transmission between roller and sliding bar.
- Transmission between pinion and crown gear on turntable for superstructure slewing (if any).
- Hose guide support on sliding bar.
- Standing around the machine during placement of the machine before and after irrigation (slewing of the superstructure, placement of parking feet, lowering of the trolley loader...).
- Irrigator on two wheel trolley, when in operation.
- Operating range of the water valve/discharge solenoid valve (if fitted on the machine).
- Near the compressor when in operation (if fitted on the machine).

3

SAFETY**PAR.****DESCRIPTION**

5

Safety devices

5. SAFETY DEVICES

The following safety devices are installed on the Machine:

1. protection devices for PTO;
2. guard between roller crown gear and gearbox pinion (guards between crown gear/drive shaft/gearbox pinion if the machine has two crown gears on the roller);
3. guard on roller/sliding bar transmission;

3	SAFETY
PAR.	DESCRIPTION
6	Signs

6. SIGNS

The following signs must be installed near the Machine and its operating area:

List of Danger signs:

- Sign indicating hot surface hazard (if compressor is installed);
- Sign indicating upper limbs crushing hazard;
- Sign indicating entrapment or dragging hazard;
- Sign indicating lower limbs crushing hazard;
- Sign indicating entrapment or dragging hazard (at the PTO shaft);
- Sign indicating danger due to pressurised ducts that may be released;
- Sign indicating generic hazard.



List of Prohibition signs:

- Sign indicating prohibition for unauthorised persons to go near or stand near the machine;
- Sign indicating prohibition to remove safety devices;
- Sign indicating prohibition to perform maintenance operations with moving parts;
- Sign indicating prohibition to exceed the towing speed limit (if the Machine is approved, the limit specified on the registration paper/technical annex applies).

**List of Obligation signs:**

- Sign indicating obligation to wear the protection helmet in activities involving a falling material hazard;
- Sign indicating obligation to wear protective gloves;
- Sign indicating obligation to wear safety shoes;
- Sign indicating obligation to wear protective overalls;
- Sign indicating obligation to wear protective goggles in activities entailing a possible risk of liquid sprays or jets;



3	SAFETY
PAR.	DESCRIPTION
7	Residual risks

7. RESIDUAL RISKS

DEFINITION OF RESIDUAL RISK:

A residual risk is that remaining after all protection measures have been taken into account and implemented.

It is required to pay attention to the following residual risks which exist when using the Machine and cannot be eliminated.



Risk of entrapment and crushing between reel upright and reel during rotation while paying out the hose. Always ensure there are no people in contact with the machine and that this work area is not accessible to unauthorised persons.

Risk of crushing and entrapment between the PE hose and the hose reel. Do not come in contact with any part of the body in the area between hose and reel during machine operation. Ensure no unauthorised persons may come into contact with the machine.

Machine overturning risk on sloping ground or when parking it with cross gradient exceeding 15° and longitudinal exceeding 30° (see fig. 4.4.1);

Risk of sudden reel holder superstructure rotation (if any) if the upper base rotates on sloping ground. Perform the manoeuvre with assistance by another person to control it better.

Electrocution hazard. Ensure there are no power lines within the operating range of the irrigator to prevent the water spray from coming into contact with them, causing electrical discharges to ground through the machine's structure.

Risk of violent impact with the water sprayed by the irrigator. The water comes out of then irrigator spout with high force, therefore avoid standing in front of or near the irrigator.

Risk of violent impact with the closing caps or releasing hoses of the machine. Never release before ensuring there is no pressure.

Risk of violent impact with the circuit oil. Before operating on the hydraulic circuit, discharge oil pressure through the pump or distributors.

Accident hazard on public road.

Strictly comply with the provisions of the registration booklet.

**ATTENTION: HOT SURFACES**

The parts of the machine (compressor, if any) that may reach high temperature above 80° and that may be accessed by the operator or maintenance technician or, in the event of emergency, while performing their normal activity have been protected. Hot parts are fitted with appropriate signs and may only be reached intentionally or ignoring the specific danger sign.

4

INSTALLATION
PAR.
DESCRIPTION

1

Checking the material upon delivery

1. CHECKING THE MATERIAL UPON DELIVERY

Upon receiving the turbocar, it is recommended to check to ensure the material you received matches that in the transport document accompanying the machine and that the material has not been subject to damage or deterioration, by opening the packages if required.

Should any faults be found, the haulier firm must be alerted urgently for making the insurance claim, making the relevant note on the transport document. The shipping department of Idrofoglia S.r.l. should be informed at the same time.

Also ensure the data on the identification plate of the turbocar reflect those on the order for the machine.



All shipments are made **AT THE CUSTOMER'S COMPLETE RISK**, even if the goods are shipped free port.

4

INSTALLATION
PAR.
DESCRIPTION

2

Storage and unpacking

2. STORAGE AND UNPACKING

As soon as it is received, the turbocar and all the material in the supply must be stored in adequate premises, preferably covered and dry, especially when it is not foreseen to be actually used for a long time.

When choosing the storage premises, one should take into account that the turbocar and its accessories consist of some delicate components (electric components, electronic components, easily deformed levers and linkages etc.), therefore all the material must be stored in places away from any action by chemicals, weathering or animals such as rats, birds etc.

Should long storage times be foreseen (exceeding 6 months) and in particularly cold areas (-5°C; -10°C) it is required:

- provide for the specific treatments required by the manufacturers of the individual components;
- partially remove water from the PE hose;
- remove water from the turbine by opening the appropriate valve on it (fig. 4.2.1);

If special packaging has been requested for outdoor storage, upon receipt of the material ensure the packaging is intact and may remain so throughout the storage time.

Any packages must be opened carefully, avoiding any damage to the material during the operation. Attention must therefore be paid if using any hoists to remove wooden packages, so as not to damage parts of the turbocar, of the control panel (if any) or other components.

Also pay attention when using cutters not to scratch the painted surfaces. All packaging items (plastic bags, PVC sheets, polystyrene, planks with nails etc.) must be collected and disposed of. For these operations, strictly comply with the regulations in force on environmental pollution and with safety regulations.

(fig. 4.2.1)

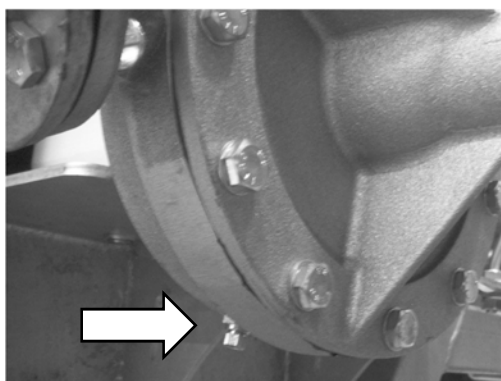

4

INSTALLATION

PAR.

DESCRIPTION

3

Lifting, handling and unloading the turbocar in the operating place

3. LIFTING, HANDLING AND UNLOADING THE TURBOCAR IN THE OPERATING PLACE



Driver of lifting and handling equipment: operator authorised to use lifting and handling equipment for materials and machines (strictly complying with the manufacturer's instructions) in compliance with the laws in force in the machine user's country.

The Machine may be transported with a normal vehicle capable of withstanding its weight and dimensions; it must only be positioned in the place of use.

In order to prevent DAMAGE TO THE OPERATOR, PERSON OR PROPERTY the following procedure must strictly be complied with:

- For lifting and unloading the turbocar **it is recommended to use a forklift truck** with adequate lifting capacity for the weight of the machine (**shown on the identification plate**) taking care to ensure the weight is properly distributed in the lifting points.
- If lifting or unloading with hoists or cranes, this may be done using four lifting hooks, adequate for the overall weight of the turbocar, by fixing them on the four attachments on the upper frame of the turbocar (fig. 4.3.1).
- If unloading with tractor, place the truck at an unloading level having the same height or place appropriate chutes that allow the machine to be slowly unloaded to the ground once the machine is hitched onto the tractor.
- It is strictly forbidden to use any other hooking points or on other components.
- Do not allow personnel to stand near the turbocar during lifting, unloading and removal operations.
- Placing the turbocar on the means of transport and perfectly anchoring it by ropes or other, is the responsibility of the haulier and must be accurately planned and monitored with the utmost attention in order to prevent shifting during transport.

Note.



The Manufacturer is not liable for damage caused to persons or property due to the use of lifting/unloading systems other than described above.

(fig. 4.3.1)

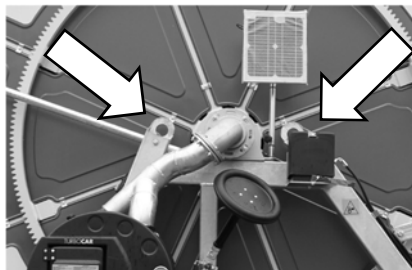

4

INSTALLATION
PAR.
DESCRIPTION

4

Transporting the turbocar in the place of operation.

4. TRANSPORTING THE TURBOCAR IN THE PLACE OF OPERATION

While transporting the turbocar with tractor, IT IS REQUIRED TO STRICTLY COMPLY with the following procedure:

While **towing the turbocar** to the place of operation:

- check the trolley tyres to ensure their pressure is adequate;
- transport the machine to the place of operation by means of a tractor having adequate towing capacity;
- ensure the trolley's towing eye is properly inserted in the tractor's seat by means of the appropriate pin with safety cotter and that the parking feet of the trolley are fully lifted;
- comply with the prohibition to transport or tow on the trolley persons or objects, even on short distances;
- have maximum transversal slope 15° and 30° longitudinal (fig. 4.4.1);
- during removal do not exceed the maximum speed of 10 Km/h (if the Machine is approved, the limit specified on the registration paper/technical annex applies). Further reduce speed in the event of uneven terrain, in order to prevent hazardous imbalance of the machine (according to the country, take into account that only approved machines may circulate on public roads).

(fig. 4.4.1)

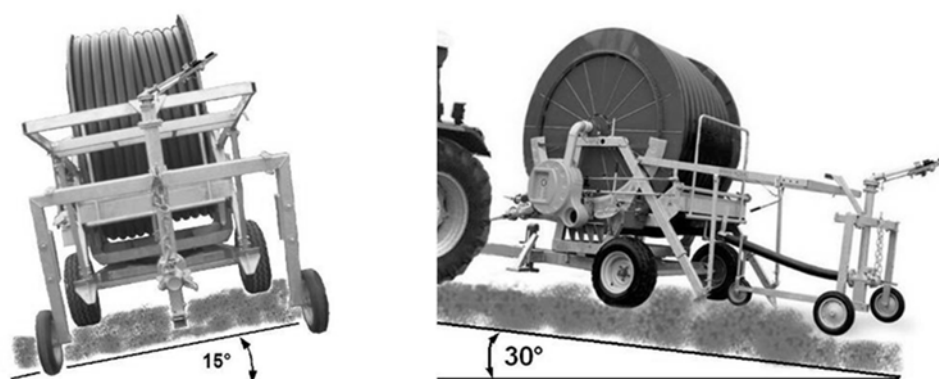

4

INSTALLATION
PAR.
DESCRIPTION

5

Assembly instructions

5. ASSEMBLY INSTRUCTIONS

Machine operator: operator authorised to use the machine (strictly following the manufacturer's instructions) in compliance with the laws in force in the machine user's country.

A good and careful operator must adhere to essential and simple rules of conduct to assure their own safety, that of others and to preserve the self-propelled machine from any damage. During preliminary operations, and subsequent maintenance operations, strictly comply with the requirements below.

- if using pressurised air (in this case the maximum pressure of the air used for cleaning must be below 2 atmospheres) use goggles and possibly a dust mask, as solid particles might be removed that might damage the operator's eyesight if they hit their eyes, as well as have an irritating effect if inhaled;
- use the protective helmet if working in an area with suspended loads or with installation at head height;
- always wear safety shoes and protective overalls;
- do not attempt performing operations you are unfamiliar with;
- always follow the instructions, and failing these contact the supplier or skilled personnel.

One should also:

- constantly check whether there are any loosened fixings;
- check the source of any abnormal noise, which if neglected might lead to faults or abnormalities;
- do not perform repairs unless expressly authorised and specifically trained for the purpose.

If the machine is delivered with disassembled trolley loader or trolley or wheels, perform assembly as follows:

5.1 ASSEMBLING THE WHEEL SUPPORTS AND WHEELS IN THE MACHINE:

In many cases the machine is delivered with assembled wheel supports; if for reasons of clearances they are disassembled during transport, assemble them as follows:

- 1) use a sling and forklift truck, crane or hoist, to lift the support with axle shaft (A), (first tie it to the cylinder connection (B) and axle shaft (C) or pin (C)), move it near the machine, insert the pin (D) and block the pin, by tightening the screw to fix the plate of the pin onto the frame (fig. 4.5.1 - 4.5.2);
- 2) place the support (A) on the ground and tie again the support (A) on the axle shaft (C) or on the pin (C) in order to simulate movement of the support (A), for easier connection of the cylinder (E), on the support (fig. 4.5.1 - 4.5.2);
- 3) cut the wire blocking the cylinder (E) on the frame and use the lever of the distributor (fig. 4.5.3), after connecting it to the hydraulic system (through quick couplings to the tractor or through a diesel or petrol engine etc.) in order to extract the rod of the cylinder (E) (fig. 4.5.1 - 4.5.2);
- 4) now the support must be lifted (see paragraph 4.5.1.2) and the rod must be extracted (see paragraph 4.5.1.3) so that the bush of the cylinder rod (E) goes near the coupling (B) of the support (A), in order to be able to insert the pin (F) and block it, by tightening the screw, to fix the plate of the pin on the support (A) (fig. 4.5.1 - 4.5.2).

If the machine has four rocker wheels (not standard) once the support (A) is mounted (see paragraph 4.5.1), the rocker must be lifted (G), tying it on the axle shafts (H), with the aid of a sling and forklift truck, crane or hoist then insert the rocker on the pin (C) of the support. Finally, fix the washer and screw on the head of the pin (C), to stop the rocker from coming out (fig. 4.5.1 - 4.5.2).

For larger machines, triangle extension (L) must be mounted on the frame of the machine, near the joint of the support (I) (fig. 4.5.4).

(fig. 4.5.1)

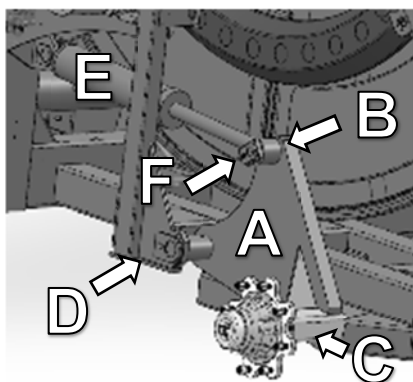

(fig. 4.5.2)

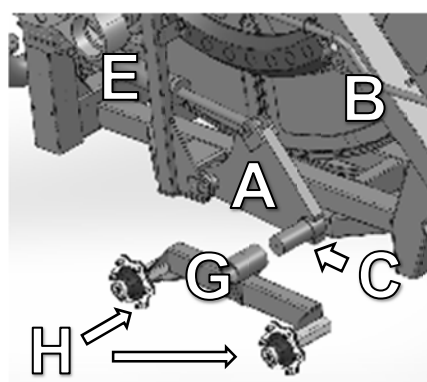

(fig. 4.5.3)



(fig. 4.5.4)

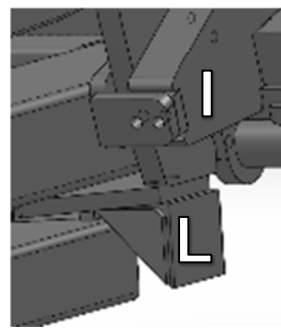

Finally, mount the wheels and fix them with the appropriate nuts (fig. 4.5.5), lifting the support (A), operating the distributor lever, after connecting the distributor to the hydraulic system (through quick couplings to the tractor or through a diesel or petrol engine etc.).

(fig. 4.5.5)



5.2 ASSEMBLY OF THE DRAWBAR, EYE, BOOM FEET (WHERE PRESENT) AND DRAWBAR LIFTER FOOT/FEET:

In most cases the drawbar, the boom feet (where present) and eye as well are delivered assembled on the machine. Should they be disassembled due to transport reasons, assemble them as follows:

- 1) use a sling and forklift truck, crane or hoist, and lift the drawbar (M) to move it near the plates or plate of the base (see arrows fig. 4.5.6 - 4.5.7), in order to be able to fix it to the frame with screws, washer, Grover and nuts (fig. 4.5.6 - 4.5.7);
- 2) prepare the eye (N) and fix it with pins and cotters in the preferred position (fig. 4.5.6 - 4.5.7 - 4.5.7 - 4.5.9);
- 3) mount the boom feet (where present), adjust the required height and block them with pin and cotter (fig. 4.5.10);
- 4) The drawbar lifter foot/feet (O) and the compressor (P) (if any) are almost always already mounted on the drawbar, as they are connected to the machine's hydraulic and water system; if they are disassembled, the foot and the compressor must be moved near the coupling on the drawbar and fixed with screws, washers, Grover and nuts to the plate on the drawbar (see arrows fig. 4.5.11 - 4.5.12) as well as connecting to the foot the oil pipes of the hydraulic system (see arrows fig. 4.5.11).

(fig. 4.5.6)

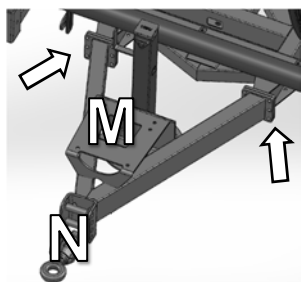

(fig. 4.5.7)

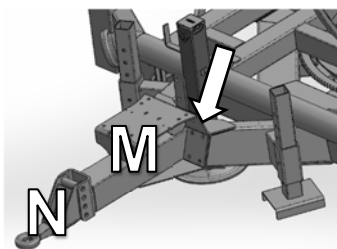

(fig. 4.5.8)



(fig. 4.5.9)



(fig. 4.5.10)

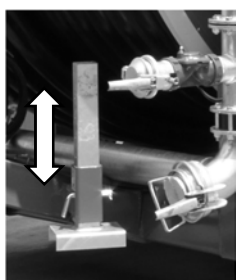

(fig. 4.5.11)



(fig. 4.5.12)

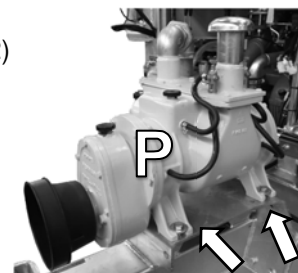

5.3 ASSEMBLY OF THE TURNTABLE, TURNTABLE HOLDER AND HYDRAULIC SLEWING MOTOR:

In many cases, when the machine is delivered to the customer, all three components are already assembled; should they be delivered disassembled, due to transport reasons, they must be assembled as follows:

- 1) place the turntable (Q) on the holder (R), with the aid of a forklift truck, crane or hoist and fix it to the holder (R), with the screws, washers and self-locking nuts, using an Allen key (fig. 4.5.13 – 4.5.14 – 4.5.15);

(fig. 4.5.13)

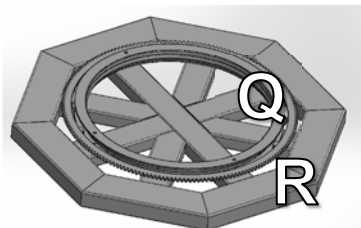

(fig.4.5.14)

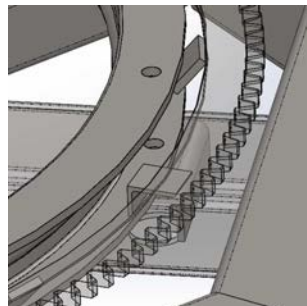

(fig. 4.5.15)



- 2) in this stage, the turntable and holder are assembled on the machine:
 - a) operate the levers of the distributor (fig. 4.5.3), after connecting it to the hydraulic system (through quick couplings to the tractor or through a diesel or petrol engine etc.) lift the machine from the ground (lower the wheels and drawbar lifter foot/feet), so that the operator is able to lie down underneath to fit the motor (fig. 4.5.16);

BEFORE GOING UNDER THE MACHINE PLACE SAFETY SUPPORTS BETWEEN THE MACHINE AND THE GROUND (fig. 4.5.16).

(fig. 4.5.16)

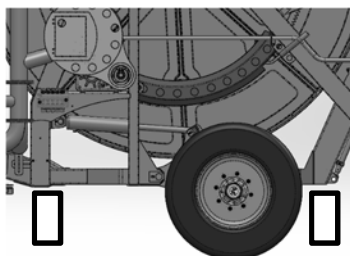

- b) after cutting the blocking wire, insert the hydraulic motor (S) in the appropriate plate of the base and fix it with the screws and nuts (fig. 4.5.17);

(fig. 4.5.17)

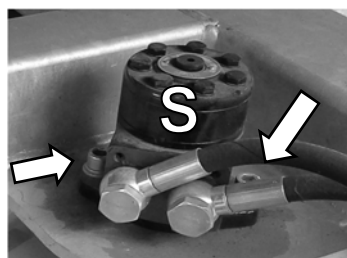

- c) insert the pinion (T) in the shaft of the hydraulic motor (S) and block it with screw, Grover and washer (fig. 4.5.18);

(fig. 4.5.18)

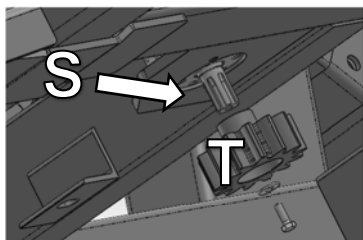

- d) insert the turntable and holder that were prepared before (see paragraph 4.5.3.1), under the machine, using a forklift truck and rotate the turntable so that its holes are near the couplings on the machine base (fig. 4.5.19);

(fig. 4.5.19)

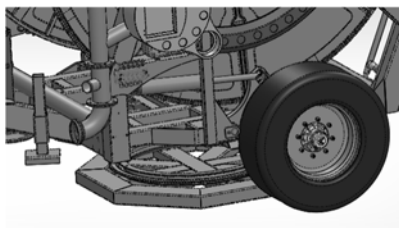

AFTER PERFORMING THIS OPERATION, THE SAFETY SUPPORTS BETWEEN THE GROUND AND THE MACHINE MAY BE REMOVED (fig. 4.5.16).

- e) operate (SLOWLY) the levers of the distributor (fig. 4.5.3), after connecting it to the hydraulic system (through quick couplings to the tractor or through a diesel or petrol engine etc.) lower the machine to the ground (lift the wheels and foot/feet), so that the base is moved closer to the turntable;

ENSURE THE MOTOR PINION TEETH MESH WITH THE CROWN GEAR TEETH ON THE TURNTABLE.

THE MACHINE MUST NOT BE RESTING ON THE TURNTABLE BUT ALWAYS SUPPORTED BY THE WHEELS AND DRAWBAR LIFTER FOOT.

TO ACHIEVE BETTER CENTRING OF THE TURNTABLE/HOLDER, ROTATE THE TURNTABLE AND USE AN IRON POLE TO MOVE THE WHOLE BY A FEW MILLIMETRES.

- f) fix the turntable to the machine by tightening screws and self-locking nuts (fig. 4.5.20);

(fig. 4.5.20)

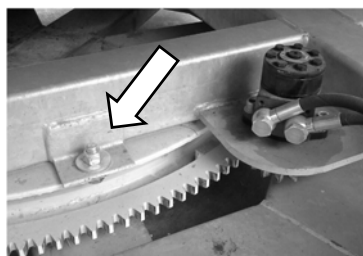

- g) use the distributor lever (fig. 4.5.3), after connecting the distributor to the hydraulic system (through quick couplings to the tractor or through a diesel or petrol engine etc.) lift the machine (lower the wheels and drawbar lifter foot/feet) so that the turntable holder does not touch the ground and rotate the turntable by 360° (either clockwise or anti-clockwise) to ensure the turntable/holder turn centred and that there are no points where the crown gear forces the pinion of the hydraulic motor.

IF THE CROWN GEAR FORCES THE PINION OF THE HYDRAULIC MOTOR, THE MACHINE MUST BE LOWERED AGAIN, SO THAT THE TURNTABLE HOLDER TOUCHES THE GROUND, LOOSEN THE NUTS FIXING THE TURNTABLE TO THE FRAME AND USE AN IRON POLE TO TRY AND MOVE THE TURNTABLE; ONCE THE TURNTABLE HAS BEEN MOVED, TIGHTEN THE SCREWS AGAIN AND TRY ROTATING AGAIN (SEE PARAGRAPH 4.5.3.2.e - 4.5.3.2.g)

- h) After checking the whole, check tightening of the screws of the turntable and hydraulic motor again.

IT IS VERY IMPORTANT FOR THE MACHINE USER, AFTER PERFORMING 3-4 IRRIGATIONS, TO CHECK THAT THE SCREWS AND NUTS OF THE TURNTABLE AND HYDRAULIC MOTOR ARE NOT LOOSENED; IF SO TIGHTEN THE SCREWS.

5.4 SPADE ASSEMBLY:

For most cases, the spades (U) are already mounted on the machine; should they not be mounted they must be prepared (U) inserted and fixed with screws and self-locking nut on the extension (V) (fig. 4.5.21 – 4.5.22). It is very important to know that spades are not all the same for all the machine models, that is why the protruding part of the spade must always be placed outwards (fig. 4.5.23);

(fig. 4.5.21)

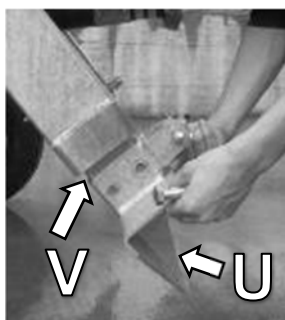

(fig. 4.5.22)

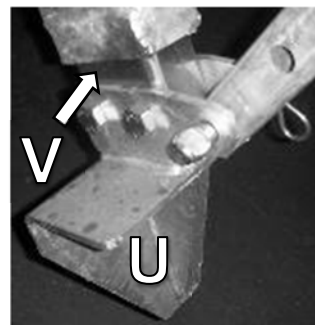

(fig.4.5.23)

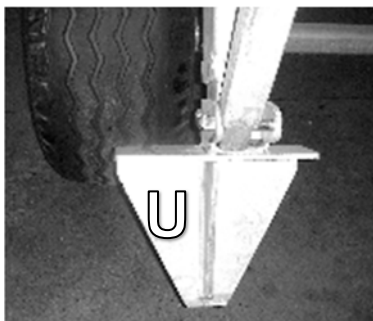

5.5 ASSEMBLY OF THE TROLLEY LOADER AND VERTICAL EXTENSIONS:

For most cases, the trolley loader and the vertical extensions are already assembled and are tied to the machine with wire, therefore:

- 1) cut the blocking wire (see arrow fig. 4.5.24);
- 2) lower the trolley loader (Z) and the extensions (AA) with forklift truck or crane (see paragraph 4.3);
- 3) extract the extensions and fix them with the relevant pin and cotter to the spade (U) (fig. 4.5.25);

(fig. 4.5.24)



(fig. 4.5.25)



If the machine is delivered with trolley loader and extensions disassembled:

- 1) use a forklift truck or crane (see paragraph 4.3) to lift the trolley loader (BA) and fix it with screws and self-locking nuts on the two attachments (CA) welded on the frame (fig. 4.5.26);
- 2) while keeping the trolley loader on the forklift truck or crane, extract the extensions (AA) and fix them with the appropriate pin and cotter to the spade (U) (fig. 4.5.25);

(fig. 4.5.26)

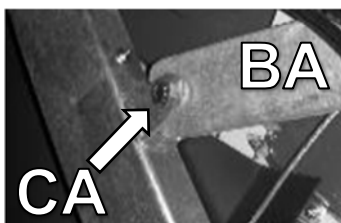

5.6 ASSEMBLY OF THE WATER SYSTEM

For transport reasons (rarely) the water system is disassembled; if the water system is disassembled, each component must be lifted and use slings and a forklift truck, crane or hoist to assemble, fixing each component with screws and nuts.

The photos below show two systems of the machines that in certain cases are disassembled (fig. 4.5.27 – 4.5.28).

WHEN ASSEMBLING THE SYSTEM PAY ATTENTION TO FITTING THE SEAL AND NOT TO DAMAGE THE GASKETS.

(fig. 4.5.27)

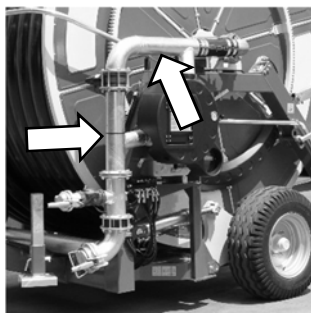

(fig. 4.5.28)



5.7 ASSEMBLY OF COMPONENTS/ACCESSORIES:

It is now possible to assemble (if disassembled) any other components or accessories (if any) such as casing, handwheel, approval, solar panel, flashing light, hose reel, second irrigator kit, light bar, tool box (some photos are shown below).

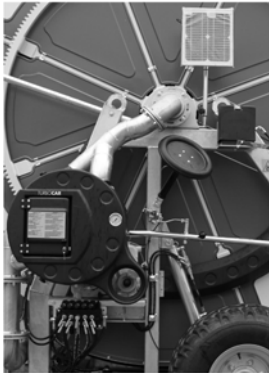

Casing and handwheel

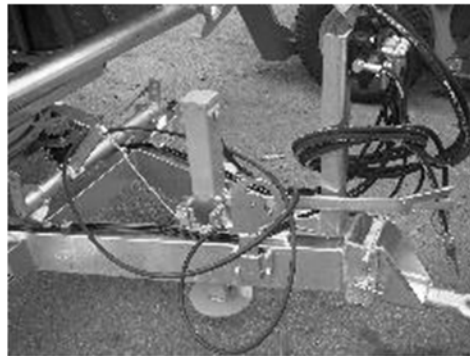

Approval



Flashing light



panel

Solar

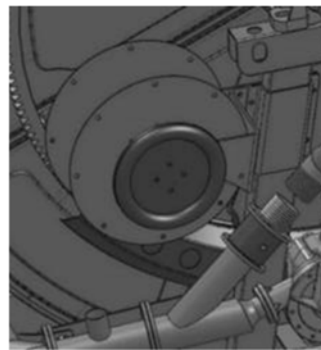

Hose reel



Light bar



Second irrigator kit

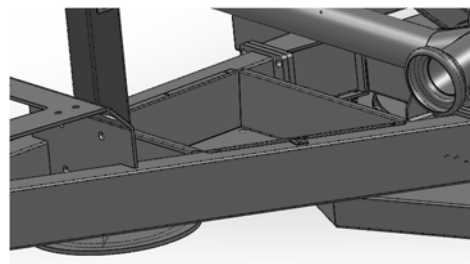

Tool box

5.8 HOSE UNWINDING TO FIX TROLLEY:

In this stage, the machine is prepared to be connected to the irrigator trolley, to do so:

- 1) tie a strap to the flange of the hose limit stop slide (fig. 4.5.29);
- 2) remove the ratchet (DA) (roller crown blocking stop), possibly using the handwheel on PTO (fig. 4.5.30);
- 3) disengage the gear (see paragraph 5.2.2 - UNWINDING);
- 4) pay out 3-4 m of PE hose using the tractor;
- 5) insert the ratchet (S) (roller crown blocking stop), possibly using the handwheel on PTO (fig. 4.5.31);

THE HANDWHEEL MUST NEVER BE LEFT ENGAGED IN THE GEARBOX PTO

IT IS IMPORTANT NOT TO PAY OUT THE HOSE WITH GEAR ENGAGED AND RATCHET INSERTED

(fig. 4.5.29)



(fig. 4.5.30)

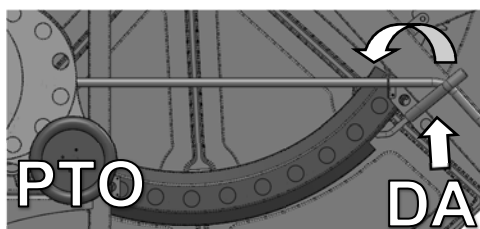

(fig. 4.5.31)

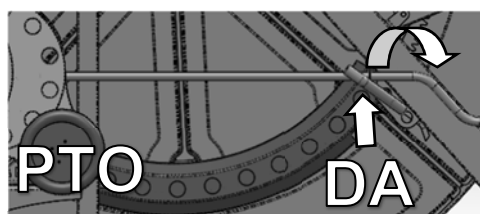

5.9 PREPARATION OF THE IRRIGATOR TROLLEY:

- In most cases the irrigator trolley is loaded assembled, with the exception of the irrigator; as the case may be this will be fixed to the trolley by threading (fig. 4.5.32) or by flange with screws and nuts (fig. 4.5.33).

It is very important to put some Teflon on the trolley connection, in the case of irrigator with threading or a gasket (supplied with the irrigator) in the case of flanged irrigator.

As there are various variables on the trolleys, some photos are listed below for easier assembly of components as well.

(fig. 4.5.32)

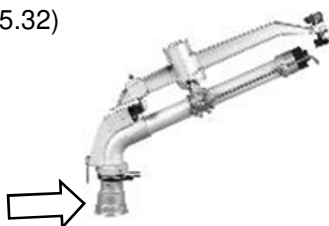

(fig. 4.5.33)

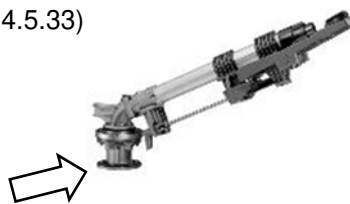



Trolley IG1.1-IG1.1S

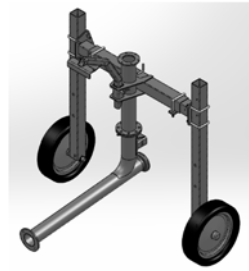

Trolley IG1.1S-IG1-IG1S-IG2

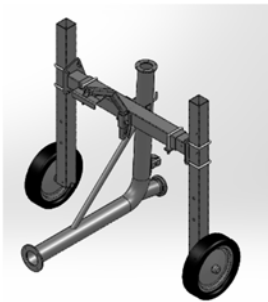

Trolley IG2-IG3-IG4-IG5



Trolley off axis



Overtree trolley



Underfoliage trolley



Corn type trolley



HP trolley



4 swivel wheels



Cast iron wheels



Direction discs



Extension for irrigator



Concrete ballasts



Iron ballasts



Ballast water tank

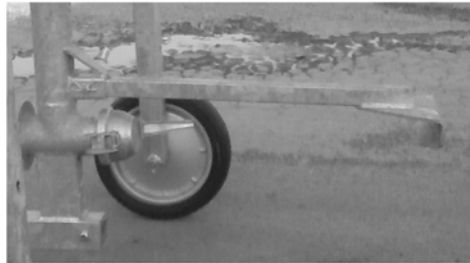

Rigid drawbar



Small irrigator



Adjustable legs
In height

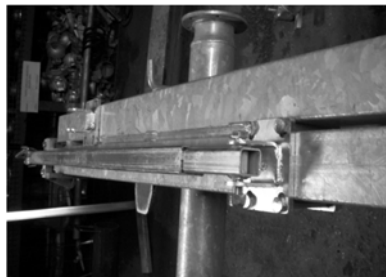

Width adjustable legs

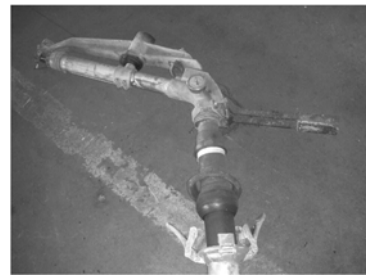

Quick release



Supplementary valve



Pneumatic wheels

5.10 TROLLEY HOSE FIXING:

In this stage the hose is connected to the flange of the irrigator trolley. To do so:

- 1) fix the flange of the limit stop slide (EA) with the flange of the trolley (FA) (only lower screws) (fig. 4.5.34);
- 2) insert gasket (fig. 4.5.35);
- 3) tighten the remaining upper screws and block all screws;

(fig. 4.5.34)

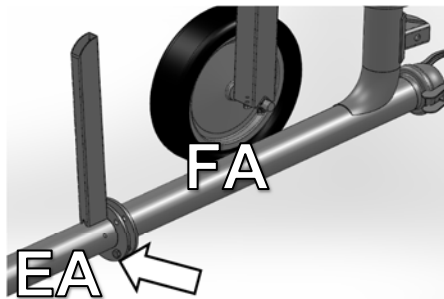

(fig. 4.5.35)

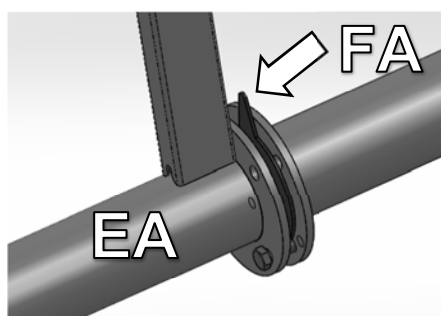

In some machine models a spacer (GA) must be mounted on the limit stop slide (EA) (fig. 4.5.36).

(fig. 4.5.36)

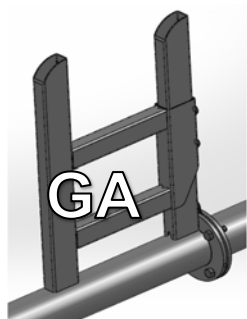

5.11 TROLLEY LOADER LOWERING, HOSE REELING IN, TROLLEY LOADER ADJUSTMENT, TROLLEY HITCHING AND TROLLEY LOADER LIFTING:

In these stages the trolley is mounted on the machine, in order to be ready for the irrigation stage:

- 1) Lower the trolley loader, until the spades are resting on the ground, using the levers of the distributor (fig. 4.5.3), after connecting it to the hydraulic system (through quick couplings to the tractor or through a diesel or petrol engine etc.); Ensure the machine is resting on the ground on the turntable holder and possibly the drawbar lifter foot (the wheels must not be resting on the ground).

2) Hose winding:

- 1) Ensure the ratchet (roller crown blocking stop) is inserted and the gear is disengaged (see paragraph 5.2.2 - PAYING OUT);
- 2) reel the hose in with the PTO (fig. 4.5.37) until the stroke end slide (EA) touches the bar joint (HA) to disengage the gear and the trolley lifting hook (IA) is near the trolley loader (BA) (4.5.38);

(fig. 4.5.37)

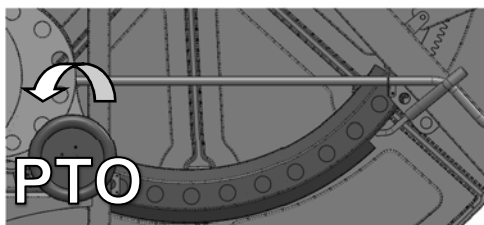

(fig. 4.5.38)

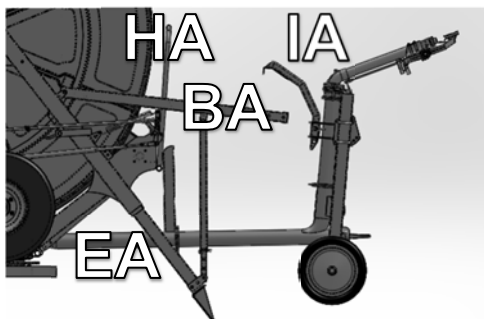

THE HANDWHEEL MUST NEVER BE LEFT ENGAGED IN THE GEARBOX PTO

3) Trolley loader adjustment:

- 1) remove pin and cotter (fig. 4.5.39);
- 2) extract and adjust length of the internal trolley loader (LA) (fig. 4.5.40); it is very important to leave about half of the internal trolley (LA) inside the external trolley loader (MA);
- 3) fix pin and cotter;

(fig. 4.5.39)

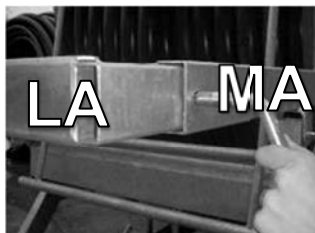

(fig. 4.5.40)

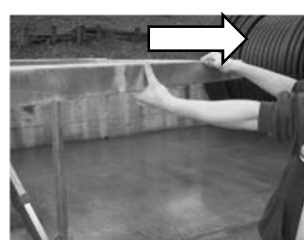

- 4) Trolley hitching: once the trolley loader is adjusted, the trolley must be hitched to it with lifting hook (IA) (fig. 4.5.41); if required it is possible to further adjust the hook (fig. 4.5.42);

(fig. 4.5.41)



(fig. 4.5.42)

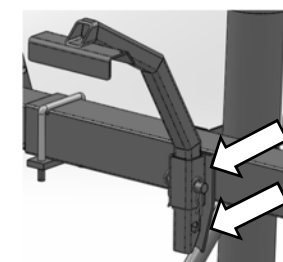

IT IS IMPORTANT TO CHECK THAT, WITH MACHINE POSITIONED TO THE GROUND (SPADES FIXED IN THE GROUND) THE LIMIT STOP SLIDE IS ABLE TO GO UNDER THE TROLLEY LOADER, THEREFORE THE TROLLEY LOADER MUST ALWAYS BE PROPERLY ADJUSTED (SEE PARAGRAPH 4.5.11.3) (fig. 4.5.43). IF REQUIRED, IN ORDER TO HAVE MORE CLEARANCE, THE STROKE END OF THE TROLLEY LOADER MUST BE ADJUSTED BY LIFTING THE SCREW (fig. 4.5.44)

(fig. 4.5.43)

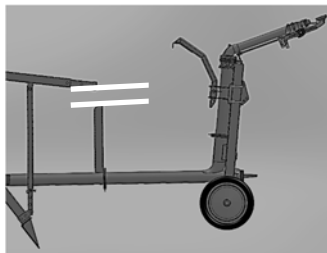

(fig. 4.5.44)

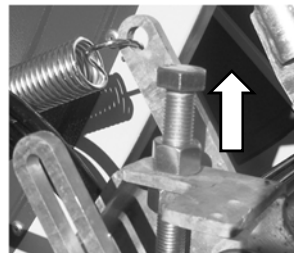

- 5) Lift the trolley loader then the trolley as well, until the spades reach the stroke end, using the levers of the distributor (fig. 4.5.3), after connecting it to the hydraulic system (through quick couplings to the tractor or through a diesel or petrol engine etc.);
At this stage, also by operating the distributor levers (fig. 4.5.3), it is possible to lift the machine on the wheels and on the drawbar, ready to be hitched to the tractor (fig. 4.5.45).

(fig. 4.5.45)



4

INSTALLATION
PAR.
DESCRIPTION

6

Connection of the starter batteries

6. CONNECTION OF THE STARTER BATTERIES

Machine operator: operator authorised to use the machine (strictly following the manufacturer's instructions) in compliance with the laws in force in the machine user's country.



The turbocar is supplied with 12 V starter battery with variable capacity, if there is an automatic control unit installed on the machine.

- the batteries are shipped already charged, ready for use, but with cables disconnected to prevent problems during transport. IN sea shipping and when it is not permitted to send charged batteries, the battery is supplied empty with separate acid container; in these cases the batteries must be filled and fully charged;
- use protective gloves and protective goggles when handling the battery, because the electrolyte contains sulphuric acid that may cause burns. In the event of contact with the skin or clothes rinse with plenty of water; in the event of ingestion immediately seek medical attention;
- before connecting the batteries it is required to check that any damage during handling or overturning have not caused electrolyte leaks;
- when starting up the turbocar the battery cables need to be connected to the relevant poles, paying attention not to invert the polarity; ALWAYS connect the positive terminal first (+) then the negative one (-);
- incorrect connection may cause damage to the control unit;
- both during operation and at rest, keep the turbocar on a flat surface; maximum tolerated slope for the battery is 30 degrees on 4 sides;
- periodically check to ensure the electrolyte level is above the minimum recommended level; any battery top ups must only be performed with distilled and de-mineralised water (see instructions below);
- do not start or top up the battery on the machine, any acid leaks may corrode and damage important components of the turbocar;
- in the event of replacing the battery, when disposing of the waste battery the anti-pollution regulations in force in the country of use must be complied with;



The company disclaims any liability for damage to the motor pump unit caused by acid leaks from the battery.

4

INSTALLATION
PAR.
DESCRIPTION

7

Topping up and charging the battery

7. TOPPING UP AND CHARGING THE BATTERY

Machine operator: operator authorised to use the machine (strictly following the manufacturer's instructions) in compliance with the laws in force in the machine user's country.



Take down the battery (if any) from the machine by disconnecting the poles before performing any operation on the battery.

To charge the battery, it must be connected to current in ampere 1/10 of the battery capacity, until reaching 16 V voltage under charge (for example batteries on 50 Ah at 5 A). After this procedure, at rest and at ambient temperature the battery voltage is between 12.7 and 12.9 V. at the terminals. However, pay attention that in the case of storage exceeding 6 months, irreversible sulphation might be produced on the plates, with consequent decrease in battery performance and service life.



NEVER RECHARGE A BATTERY BEFORE READING THE BATTERY CHARGER INSTRUCTIONS FIRST.

In addition to the instructions of the battery charger manufacturer, adhere to the following general precautions:

- Always wear adequate eye and hands protection.
- Always charge the batteries in adequately ventilated premises.
- Keep the vent valves properly closed and at level.
- Switch off the charger and the timer (set to OFF) before connecting the cables to the battery to prevent dangerous sparks.
- Never try charging a visibly damaged or frozen battery.
- Connect the charger cables to the battery; the red positive cable (+) to the positive pole (+) and the black negative cable (-) to the negative pole (-).
- Ensure the cables of the battery charger connected to the battery are not broken, worn or loose.
- Set the timer, switch on the charger and slowly increase the charging speed until achieving the desired current intensity.
- If the battery heats up, or a violent emission of gas or electrolyte leak should occur, reduce the charging speed or temporarily switch off the charger.
- Always switch off the charger before disconnecting its cables from the battery to prevent dangerous sparks.

For topping up, the battery must be filled with sulphuric acid at the density required by the manufacturer (usually 1.27 Kg/l) up to the indicated level (about 10-15 mm above the plates, temperature above 15°C). Wait at least 30 minutes before installation on board. During cold periods or if storage exceeds 6 months, before charging the battery, let it “stand” and cool for at least 3-4 hours.

4	INSTALLATION
PAR.	DESCRIPTION
8	Instructions for commissioning

8. INSTRUCTIONS FOR COMMISSIONING



Machine operator: operator authorised to use the machine (strictly following the manufacturer’s instructions) in compliance with the laws in force in the machine user’s country.

Before starting up the Machine, the following operations must be performed each time:

- Check all safety systems
- Check guards
- Check signs

Before starting up the Machine, it is required to perform a series of checks and inspections in order to prevent errors or accidents during start-up:

- ensure the machine has not been damaged during transport and placement;
- check with special care the integrity of the control panel, electric cables and pipes.

During preliminary operations, strictly comply with the instructions listed below.

- in all activities performed, comply with the provisions and instructions given by one’s employer for the purpose of collective and personal protection;
- under any circumstances, strictly comply with the provisions of this manual, if necessary contact the supplier or skilled personnel;
- do not perform on one’s own initiative operations or manoeuvres that are not under one’s responsibility or that might undermine one’s safety or that of others;
- never wear loose clothes, rings, bracelets or chains when working near moving parts;
- use the protective helmet to prevent impacts against sharp parts of the machine at head height,
- always wear safety shoes and protective overalls;
- use protective cream for the hands or gloves because contact with certain substances present or used might be harmful for the skin;
- immediately replace wet overalls;
- during adjustment operations ensure your hands and feet are always dry;
- procure adequate and safe containers for waste oil.

One should also:

- constantly check whether there are any loosened fixings;
- check the source of any abnormal noise or vibrations, which if neglected might lead to faults or abnormalities;
- immediately report oil leaks or acid leaks from the batteries;
- do not perform repairs unless expressly authorised and specifically rained for the purpose.

**ATTENTION**

BEFORE COMMISSIONING IT IS REQUIRED TO READ THE INSTRUCTIONS, ALWAYS SUPPLIED WITH THE TURBOCAR, CONTAINED IN THE INSTRUCTIONS OF:

IRRIGATOR

CONTROL UNIT (IF ANY)

COMPRESSOR (IF ANY)

5	USE OF THE MACHINE
PAR.	DESCRIPTION
1	Checks before starting up the turbocar

1. CHECKS TO BE PERFORMED AND PREPARATION BEFORE STARTING UP THE TURBOCAR



Machine operator: operator authorised to use the machine (strictly following the manufacturer's instructions) in compliance with the laws in force in the machine user's country.



Mechanical maintenance technician: skilled technician, able to operate the machine in normal conditions, to act on mechanical parts, to perform the required adjustments, maintenance and repairs. **Typically, they are not authorised to perform operations on live electrical systems.**



Manufacturer's technician: skilled technician, provided by the manufacturer to perform operations of a complex nature in special situations or however agreed with the user. As the case may be, their skills are mechanical, electrical or electronic.



Perform an accurate visual inspection of the whole Machine and ensure there are no people near it or materials that might hinder normal operation, or any objects accidentally left on it.

Before starting up the machine, IT IS OBLIGATORY TO CHECK that:

- there are no rags or other foreign objects on the machine;
- the safety pictorials (decals) are always clearly visible; they must be kept clean and must be replaced if they become poorly legible as they provide the appropriate recommendations in an essential for to prevent accidents;
- the electrolyte level and the charge condition of the battery (if any) are perfect;
- the fixed guards of the unit on rotating parts, etc. are always present.

During preparation of the turbocar, the following points must be adhered to:

- 1) move the machine to the place where it is to be parked for irrigation; when choosing the placement it is required to ensure that:
 - the ground on which the turbocar is placed is sufficiently firm;
 - the ground on which the turbocar is placed is sufficiently level;
 - there is enough space around the turbocar for the operator;
- 2) lower the drawbar lifter foot/feet, unhitch the machine from the tractor and prepare it for irrigation; in this operation it is required to:
 - a) lower the drawbar lifter foot or feet (A) (the machine is lifted) with the distributor lever (B) after connecting it to the hydraulic system (through quick couplings to the tractor or through a diesel or petrol engine etc.) so as to lift the machine and release it from the tractor (fig. 5.1.1 – fig. 5.1.2);
 - b) if present, disconnect the lights bar and braking systems from the tractor;



(fig. 5.1.1)



(fig. 5.1.2)

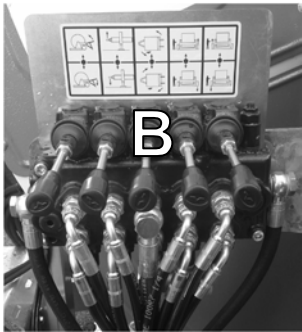

- c) after moving the tractor a few metres from the machine, place the turbocar on the turntable support (fig. 5.1.3), lifting the wheels and the drawbar lifter foot or feet, using the distributor lever (B) after connecting it to the hydraulic system (through quick couplings to the tractor or through a diesel or petrol engine etc.);

(fig. 5.1.3)

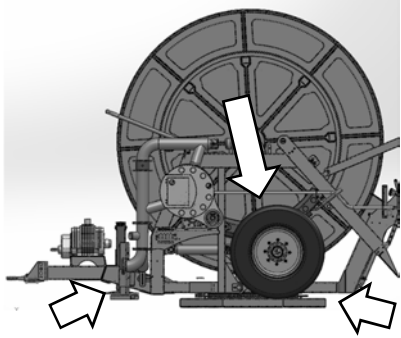

- 3) according to the field to be irrigated, if required, rotate the turbocar clockwise or anti-clockwise (fig. 5.1.4), by carefully using the distributor lever (B) (fig. 5.1.2) after connecting it to the hydraulic system (through quick couplings to the tractor or through a diesel or petrol engine etc.);

(fig. 5.1.4)

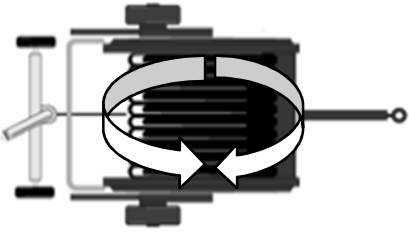

! PAY ATTENTION DURING ROTATION OF THE TURBOCAR TO ENSURE THE QUICK COUPLING PIPES (IF ANY), DO NOT GET ENTANGLED OR HOOKED INTO PARTS OR COMPONENTS OF THE MACHINE, CAUSING THEM TO BREAK;

! ROTATION OF THE BASE IS A VERY IMPORTANT OPERATION, BECAUSE THE MACHINE MUST BE POSITIONED SO THAT THE PE HOSE IS PAID OUT IN THE FIELD AS PERPENDICULAR AS POSSIBLE TO THE MACHINE (fig. 5.1.5);

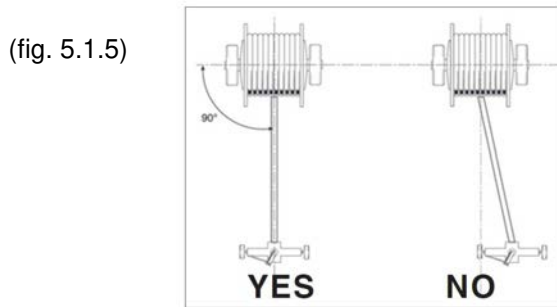

4) anchoring the machine to the ground: **!**

- where present, lower the boom feet, by removing then placing back the pin and cotter, so that the teeth of the boom feet are able to grip the ground (fig. 5.1.6);

(fig. 5.1.6)

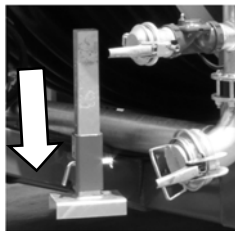

- carefully act on the distributor lever (B) (fig. 5.1.2), after connecting it to the hydraulic system (through quick couplings to the tractor or through a diesel or petrol engine etc.) to lower the spades until they penetrate as deep as possible into the ground (fig. 5.1.7); with this operation to anchor the spades to the ground, the trolley loader is also lowered, and consequently the trolley is released from the trolley loader (fig. 5.1.7);

(fig. 5.1.7)

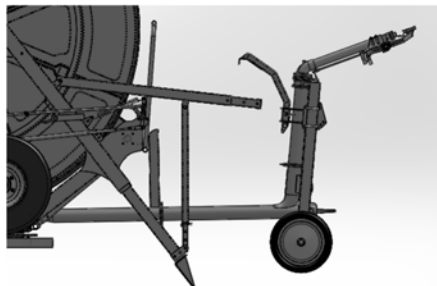

! DURING OPERATION THE MACHINE MUST BE PROPERLY ANCHORED TO THE GROUND, SO AS NOT TO CAUSE SKIDDING OR OVERTURNING.

5	USE OF THE MACHINE
---	---------------------------

PAR.	DESCRIPTION
2	Starting up

2. STARTING UP



Machine operator: operator authorised to use the machine (strictly following the manufacturer's instructions) in compliance with the laws in force in the machine user's country.



Mechanical maintenance technician: skilled technician, able to operate the machine in normal conditions, to act on mechanical parts to perform the required adjustments, maintenance and repairs. **Typically, they are not authorised to perform operations on live electrical systems.**



Manufacturer's technician: skilled technician, provided by the manufacturer to perform operations of a complex nature in special situations or however agreed with the user. As the case may be, their skills are mechanical, electrical or electronic.

Perform an accurate visual inspection of the whole Machine and ensure there are no people near it or materials that might hinder normal operation, or any objects accidentally left on it.

Before starting up the machine, IT IS OBLIGATORY TO CHECK that:



- there are no rags or other foreign objects on the machine;
- the safety pictorials (decals) are always clearly visible; they must be kept clean and must be replaced if they become poorly legible as they provide the appropriate recommendations in an essential for to prevent accidents;
- the electrolyte level and the charge condition of the battery (if any) are perfect;
- the fixed guards of the unit on rotating parts, etc. are always present.

The operation for starting up the self-propelled machine can be broken down into:

- PAYING OUT;
- IRRIGATION;
- QUICK REELING IN THROUGH PTO (AS AN ALTERNATIVE TO STANDARD IRRIGATION);

- **PAYING OUT:** proceed as follows to pay out the hose:

- 1) connect one end of the flexible hose to the water inlet of the machine (fig. 5.2.1) while leaving the other end free (fig. 5.2.2), possibly in a ditch next to the machine, so that the water is able to come out for easier hose paying out (lighter), and to prevent any air bubbles from forming inside the PE hose;

(fig. 5.2.1)

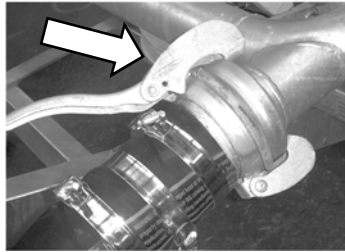

(fig. 5.2.2)



ENSURE ALL FITTINGS HOOKS ARE PROPERLY INSERTED:



PAY ATTENTION TO THE CONDITION OF GASKETS:



ENSURE THE SECOND INLET OF THE WATER SYSTEM IS CLOSED WITH THE CAP SUPPLIED (fig. 5.2.3):

(fig. 5.2.3)

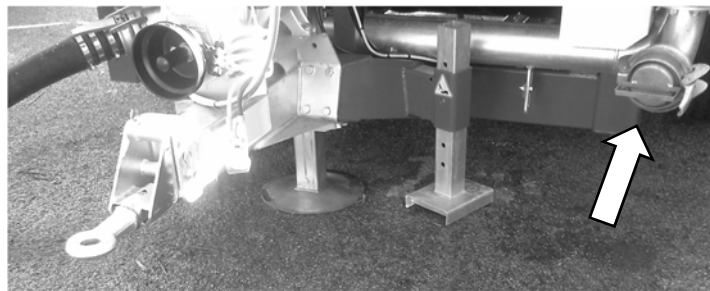

IT IS RECOMMENDED TO PLACE A PROTECTION FILTER BETWEEN THE MACHINE'S INLET AND THE HOSE, FOR ANY STONES AND DIRT THAT MIGHT DAMAGE THE TURBINE IMPELLER (fig. 5.2.4):

(fig. 5.2.4)

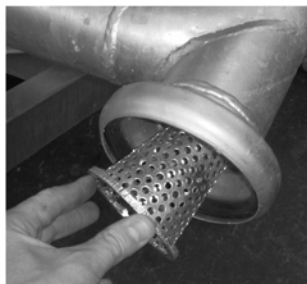

- 2) place the gear release lever on "0" STOP, in order to prevent speed increase on the upper axles of the gearbox and cause impeller breakdown. In most machines the gear is released by applying force on the black knob of the lever and pushing left (fig. 5.2.5); it is very important to ensure the position of the lever on the gearbox is "0" (fig. 5.2.6 – 5.2.7); In larger machines, to release the gear, however, one must push towards the machine always by means of the black knob (fig. 5.2.8);

(fig. 5.2.5)



(fig. 5.2.6)



(fig. 5.2.7)



(fig. 5.2.8)



- 3) the gear knob may be in any position (fig. 5.2.9); in larger machines with 2-gear gearbox the lever must be in the central position "0" and secured with the appropriate pin stop (fig. 5.2.10);

(fig. 5.2.9)



(fig. 5.2.10)

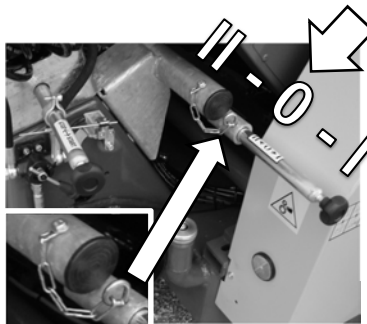

- 4) ensure the bypass is open (see paragraph 5.3.1);
- 5) slightly brake the gearbox by means of the brake on the PTO (fig. 5.2.11 – fig. 5.2.12) in order not to slacken the PE hose on the roller;

DO NOT CONNECT ANYTHING TO THE PTO;

(fig. 5.2.11)

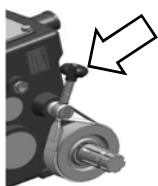

(fig. 5.2.12)

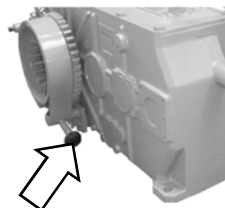

- 6) disconnect the blocking stop (A) crown gear roller (ratchet) by means of the handwheel on the PTO (fig. 5.2.13);

(fig. 5.2.13)

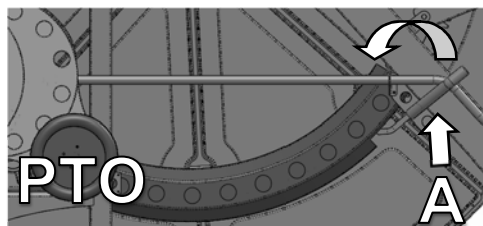

THE HANDWHEEL MUST NEVER BE LEFT ENGAGED IN THE GEARBOX PTO

- 7) place the tractor near the irrigator trolley in order to hitch it to the tractor, through the chain or rigid drawbar (optional);
- 8) start paying out the PE hose, reaching maximum speed 3 Km/h and keeping a straight trajectory (fig. 5.2.14) and constant speed, proceeding until the end of the lot to be irrigated and gradually reducing speed in the last metres;

(fig. 5.2.14)

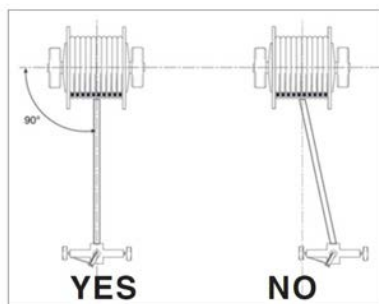

IT IS IMPORTANT TO PERFORM THE FIRST IRRIGATION BY PAYING OUT AT LEAST 85-90% OF THE HOSE LENGTH;



IF THE MACHINE IS USED BY ONLY PARTLY UNWINDING THE PE HOSE (THIS DOES NOT APPLY FOR THE FIRST IRRIGATION), IT IS RECOMMENDED:

- **TO PAY THE UTMOST ATTENTION WHILE UNWINDING THE HOSE, SO THAT THE PART OF IT THAT REMAINS ON THE ROLLER DOES NOT TEND TO SLACKEN, PAY IT OUT AT MINIMUM SPEED AND STOPPING GRADUALLY;**
- **PERIODICALLY PERFORM IRRIGATIONS DURING WHICH AT LEAST 85-90% OF THE HOSE LENGTH IS PAID OUT;**



IF THE PLOT OF LAND TO BE IRRIGATED IS LARGER THAN THE HOSE LENGTH, IT IS IMPORTANT TO KNOW THAT 2-3 HOSE COILS MUST ALWAYS BE LEFT ON THE ROLLER;



DO NOT UNWIND THE HOSE PARALLEL TO A DITCH;



DO NOT UNWIND THE HOSE ON AN UPHILL (fig. 5.2.15) OR DOWNHILL SLOPE WITH GRADIENT EXCEEDING 15% (fig. 5.2.16) OR ON UNEVEN SLOPES (fig. 5.2.17);

(fig. 5.2.15)

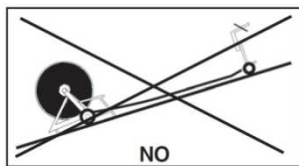

(fig. 5.2.16)

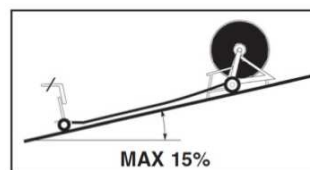

(fig. 5.2.17)

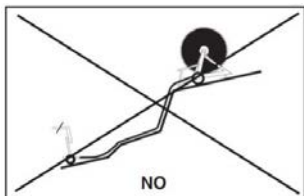

- 9) disconnect the trolley from the tractor;
- 10) ensure the angle of the irrigator range is as desired. Should you wish to change this angle, act on the appropriate inversion stops without any water;

! ENSURE THE WATER JET DOES NOT HIT POWER LINES, HIGH VOLTAGE CABLES, HOUSES, ROADS OR WORKPLACES ETC.

! BEFORE ADJUSTING THE IRRIGATOR CAREFULLY READ THE USER AND MAINTENANCE MANUAL PROVIDED WITH IT.

- **IRRIGATION:** to start irrigation, proceed as follows:

- 1) connect the blocking stop (A) crown gear roller (ratchet) by means of the handwheel on the PTO (fig. 5.2.18);

(fig. 5.2.18)

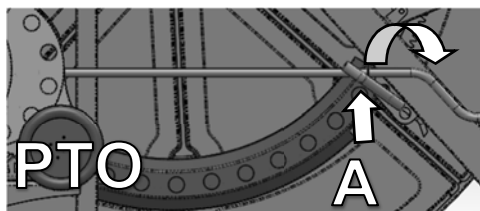

! THE HANDWHEEL MUST NEVER BE LEFT ENGAGED IN THE GEARBOX PTO

- 2) it is not required to loosen the gearbox brake on the PTO (fig. 5.2.19 – fig. 5.2.20), because it consists of a spring system that brakes when the PE hose is paid out and does not brake when the PE hose is reeled in;

! DO NOT CONNECT ANYTHING TO THE PTO;

(fig. 5.2.19)



(fig. 5.2.20)

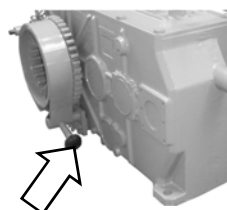

- 3) place the gear release lever on "1" START. In most machines the gear is engaged by applying force on the black knob of the lever and pushing right (fig. 5.2.21); it is very important to ensure the position of the lever on the gearbox is "1" (fig. 5.2.22 – 5.2.23); In larger machines, to engage the gear, however, one must pull outwards, always by means of the black knob (fig. 5.2.24);

(fig. 5.2.21)



(fig. 5.2.22)



(fig. 5.2.23)

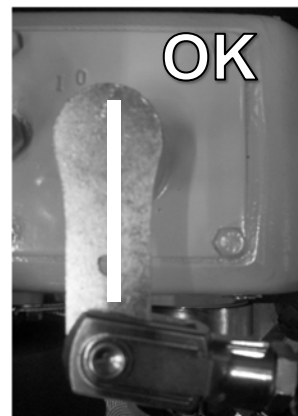

(fig. 5.2.24)



- 4) set the knob on the desired gear (I, II, III or IV) with the help of the handwheel on the PTO (fig. 5.2.25) (see paragraph 5.3.3); for larger machines the gearbox has 2 gears (I or II) and is blocked with the appropriate pin stop (fig. 5.2.26);

(fig. 5.2.25)



(fig. 5.2.26)

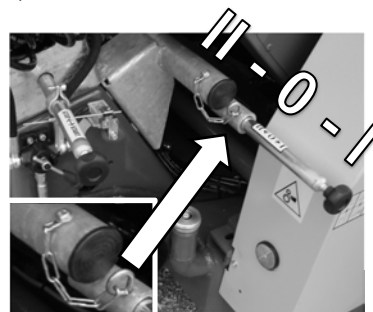

- 5) start the pumping station at MINIMUM, so that the water gets near the machine;

! BEFORE CONNECTING THE FLEXIBLE HOSE OF THE MACHINE TO THE LINE, IT IS VERY IMPORTANT FOR THE WATER PUMPED BY THE PUMPING STATION TO FLOW ON THE GROUND OR INTO A DITCH, IN ORDER TO **CLEAN THE DUCT FROM THE PUMPING STATION TO THE MACHINE**, AND TO PREVENT ANY STONES, DIRT FROM DAMAGING THE IMPELLER OR OBSTRUCTING THE MACHINE'S WATER SYSTEM PIPES (fig. 5.2.27); AFTER PERFORMING THE CHECK TURN OFF THE MOTOR PUMP;

(fig. 5.2.27)



- 6) connect the other end of the flexible hose to the water line (fig. 5.2.28), paying attention so that all fitting hooks are properly inserted (if the machine has double inlet, ensure the second inlet is closed with the cap supplied);

(fig. 5.2.28)

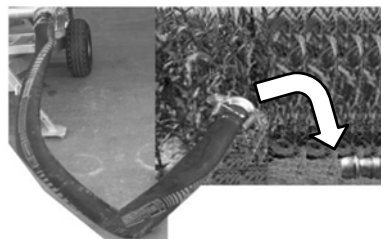

- 7) start the pumping station, so that water reaches the machine and the irrigator; then set the motor pump to operating speed;

! THE PE HOSE MUST ALWAYS BE REELED IN UNDER PRESSURE (WHILE IRRIGATING);

! DO NOT REEL THE HOSE IN ON MUDDY GROUND, FIRST RAISE IT FROM THE GROUND BY PLACING WOODEN BLOCKS EVERY 10-15 M;

! AFTER PAYING OUT THE HOSE, REEL IT IN A FEW HOURS LATER IN ORDER TO PREVENT IT FROM STICKING TO THE GROUND;

- 8) once the water has reached the irrigator and the motor pump is at operating speed, adjust the hose reeling in speed using the bypass lever; this operation changes the amount of water that goes through the turbine, and consequently the PE hose reeling in speed will be higher or lower (see paragraph 5.3.1);

! AS SOON AS HOSE REELING IN STARTS, WATCH THE MACHINE FOR A FEW MINUTES AND ENSURE IT IS PROPERLY ANCHORED TO THE GROUND AND DOES NOT TEND TO SHIFT; IN THAT CASE INCREASE THE PRESSURE OF THE FEET ON THE GROUND (see paragraph 5.1.4);

 AS THE MACHINE HAS NO INDEPENDENT ELECTRICITY SOURCE, IF IT NEEDS TO BE USED IN INSUFFICIENT NATURAL LIGHTING CONDITIONS, TO ALLOW THE OPERATOR TO PERFORM A CHECK OR MAINTENANCE ETC. ADEQUATE ARTIFICIAL LIGHTING MUST BE PROVIDED TO BE ABLE TO OPERATE SAFELY.

In many machines, automatic control units are installed to have constant hose reeling in speed; basically, all control units are powered by a battery, and through a sensor they control an electric motor fitted on the bypass valve, which adjusts the PE hose reeling in speed. Based on the type of control unit, there will be a varying number of functions, also depending on the optional features (flashing light, second irrigator, water valve, pressure switch, GSM etc.) fitted on it.

 **BEFORE STARTING THE CONTROL UNIT CAREFULLY READ THE USER AND MAINTENANCE MANUAL PROVIDED WITH IT.**

- QUICK REELING IN, THROUGH PTO (AS AN ALTERNATIVE TO STANDARD IRRIGATION): should you wish to reel in the hose with the PTO, after laying the hose in the field (see paragraph 5.2 - PAYING OUT), connect the cardan shaft to the PTO of the tractor and gearbox.

 Ascertain that:

THE CARDAN SHAFT BETWEEN TRACTOR AND GEARBOX IS CORRECTLY SIZED FOR THE POWER TO BE TRANSMITTED, IS PROPERLY CONNECTED (THE SAFETY PINS MUST BE HOUSED IN THE APPROPRIATE SEAT ON THE PTO) IS PROPERLY POSITIONED (MAXIMUM SLOPE = 10°) AND IS FITTED WITH GUARDS;

THE RELEASE LEVER IS IN POSITION "0" STOP (fig. 5.2.5 – 5.2.6 – 5.2.7 – 5.2.8); FOR LARGER MACHINES WITH 2-GEAR GEARBOX ENSURE THE GEAR LEVER IS IN POSITION "0" (see paragraph 5.2 – PAYING OUT item 3) (fig. 5.2.10);

THE CROWN GEAR BLOCKING STOP (RATCHET) IS INSERTED (fig. 5.2.18);

THE GEARBOX BRAKE OR BRAKE ON ROLLER IS LOOSENED (fig. 5.2.19 – 5.2.20).

After starting up the pumping station and performing the various checks (see paragraph 5.2 - IRRIGATION items 1,2,5,6,7), start up the tractor's PTO, to start reeling in.

 THE PE HOSE MUST ALWAYS BE REELED IN UNDER PRESSURE (WHILE IRRIGATING);

 DO NOT REEL THE HOSE IN ON MUDDY GROUND, FIRST RAISE IT FROM THE GROUND BY PLACING WOODEN BLOCKS EVERY 10-15 M;

 AFTER PAYING OUT THE HOSE, REEL IT IN A FEW HOURS LATER IN ORDER TO PREVENT IT FROM STICKING TO THE GROUND; SHOULD THIS NOT BE POSSIBLE, RUN A ROPE ALONG ITS ENTIRE LENGTH;

 AS SOON AS HOSE REELING IN STARTS, WATCH THE MACHINE FOR A FEW MINUTES AND ENSURE IT IS PROPERLY ANCHORED TO THE GROUND AND DOES NOT

TEND TO SHIFT; IN THAT CASE INCREASE THE PRESSURE OF THE FEET ON THE GROUND (see paragraph 5.1.4);



AT THE END OF IRRIGATION THE LIMIT STOP BRACKET DOES NOT RELEASE THE GEARBOX, THEREFORE, WHEN THE IRRIGATOR TROLLEY IS NEAR THE IRRIGATING MACHINE, GRADUALLY REDUCE PTO ROTATING SPEED IN THE LAST FEW METRES, UNTIL COMPLETELY STOPPED.

5	USE OF THE MACHINE
PAR.	DESCRIPTION
3	Adjustment instructions

3. ADJUSTMENT INSTRUCTIONS



Machine operator: operator authorised to use the machine (strictly following the manufacturer's instructions) in compliance with the laws in force in the machine user's country.



Mechanical maintenance technician: skilled technician, able to operate the machine in normal conditions, to act on mechanical parts to perform the required adjustments, maintenance and repairs. **Typically, they are not authorised to perform operations on live electrical systems.**



Manufacturer's technician: skilled technician, provided by the manufacturer to perform operations of a complex nature in special situations or however agreed with the user. As the case may be, their skills are mechanical, electrical or electronic.



- 1) **SPEED ADJUSTMENT:**
 To adjust the PE hose reeling in speed, act on the bypass lever. The bypass lever makes it possible to close or open the bypass valve, so that more water (closed valve) or less water (open valve) flows into the turbine.
 The bypass lever consists of 2 pipes one inserted into the other (fig. 5.3.1) and connecting the bypass valve to the bar joint.
 To move the lever and adjust the hose reeling in speed, proceed as follows:
- a) loosen the knob (A) (fig.5.3.1);
 - b) extract the hose: if moved left, the bypass is closed and PE hose reeling in speeds up (B+), if moved right, the bypass is opened and PE hose reeling in slows down (B-) (fig. 5.3.2);
 - c) block the knob (A) (fig.5.3.1);
- For larger machines, with two-speed gearbox, the standard bypass is not manual, but with a motor controlled by a control unit. Therefore bypass opening and closing is performed by controls on the control unit.

! BEFORE STARTING THE CONTROL UNIT CAREFULLY READ THE USER AND MAINTENANCE MANUAL PROVIDED WITH IT.

(fig. 5.3.1)

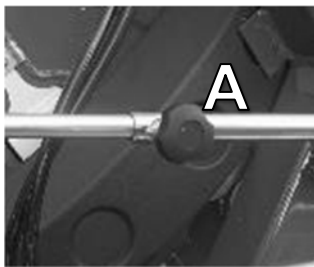

(fig. 5.3.2)

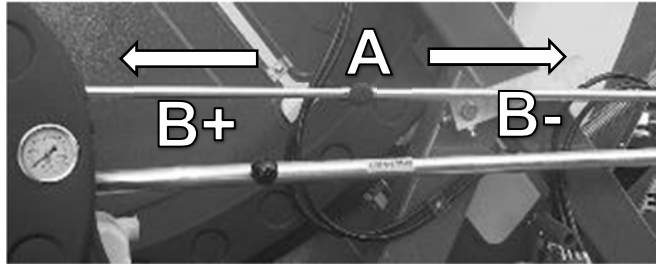

2) BYPASS VALVE ADJUSTMENT:

The bypass lever connects the bar joint to the bypass valve; this bypass valve is a speed compensator, which allows the PE hose reeling in speed to be kept as constant as possible. If hose reeling in is very variable (take into account that a speed average should always be made between the first and last layer of PE hose on the roller), the bypass lever connection must be moved on the bar joint (fig. 5.3.3 + table).

REELING IN	BYPASS	HOLE (fig. 5.3.3)
SPEED DECREASE IS EXCESSIVE	MUST BE MORE CLOSED	MOVE BYPASS LEVER LOWER (C)
SPEED INCREASE IS EXCESSIVE	MUST BE MORE OPEN	MOVE BYPASS LEVER HIGHER (D)

(fig. 5.3.3)

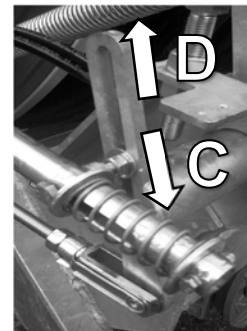

3) GEAR SHIFT:

The gear may be shifted with machine stationary (with or without pressurised water and no PE hose reeling in) as well as during the irrigation stage (with pressurised water and PE hose reeling in).

In the former case (machine stationary with or without pressurised water and no PE hose reeling in), with GEAR ENGAGED (see paragraph 5.2 - IRRIGATION item 3), it is required to act directly on the gear knob (fig. 5.3.4), choosing the desired gear (I, II, III or IV) and if required aiding with manual rotation of the PTO (fig. 5.3.5), using the handwheel (that's because the gears are not synchronised). Keeping the short tip of the gear knob as reference, from left to right there is I, II, III and IV gear (fig. 5.3.4 – E); vice versa, keeping the long tip of the gear knob as reference, from right to left there is I, II, III and IV gear (fig. 5.3.4 – F);

(fig. 5.3.4)

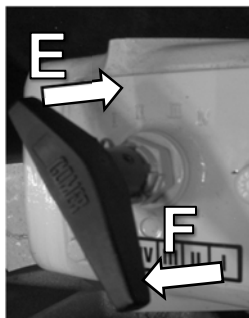

(fig. 5.3.5)



For larger machines with two-speed gearbox (always with machine stationary with or without pressurised water and no PE hose reeling in), with GEAR ENGAGED (see paragraph 5.2 - IRRIGATION item 3), it is required to act directly on the gear lever (fig. 5.3.6), choosing the desired gear (I or II) and block it with the appropriate stop and if required aiding with manual rotation of the PTO (fig. 5.3.7), using the handwheel (that's because the gears are not synchronised).

Pushing (G) the lever towards the machine engages gear II, pulling (H) the lever outwards engages gear I (in the middle position 0 no gear is selected) (fig. 5.3.6).

(fig. 5.3.6)

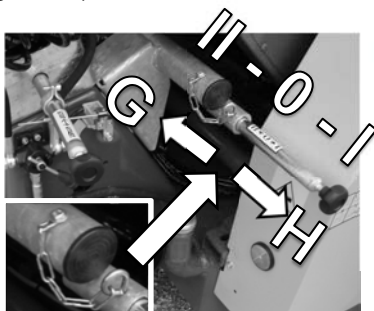

(fig. 5.3.7)



In the latter case (machine during irrigation, with pressurised hose and reeling in) it is required to:



- a) **NEVER DISCONNECT THE GEAR LEVER** (IT MUST BE PLACED ON "1" START - see paragraph 5.2 - IRRIGATION item 3)
- b) open the bypass valve almost completely, so that the turbine impeller speed is almost zero (see paragraph 5.3.1);
- c) when the impeller is at MINIMUM, (ALMOST STATIONARY) act on the gear knob to select the desired gear (I, II, III or IV - fig. 5.3.4) or (I or II -fig. 5.3.6);

It is possible to understand that the impeller is rotating at minimum speed also through the nylon roller placed between the gearbox and the turbine (fig. 5.3.8); in practice, when the roller is almost still so is the impeller of the turbine (the gear must be shifted right then).

Keeping the short tip of the gear knob as reference, from left to right there is I, II, III and IV gear (fig. 5.3.4 – E); vice versa, keeping the long tip of the gear knob as reference, from right to left there is I, II, III and IV gear (fig. 5.3.4 – F).

For larger machines with two-speed gearbox, pushing (G) the lever towards the machine engages gear II, pulling (H) the lever outwards engages gear I (in the middle position 0 no gear is selected) (fig. 5.3.6).

- d) once the gear is engaged, PE hose reeling in may be adjusted again (see paragraph 5.3.1);

(fig. 5.3.8)

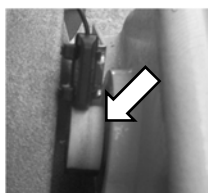

THE TABLE BELOW INDICATES THE CORRESPONDING PE HOSE REELING IN SPEED FOR DIFFERENT GEARBOX RATIOS.



THE INDICATIONS PROVIDED MUST BE CONSIDERED INDICATIVE FOR THE AIM OF PROPER MACHINE OPERATION, AS THEY DEPEND ON THE MACHINE, ON THE FLOW RATE AND ON THE GROUND CONDITIONS (FRICTION).

4-SPEED GEARBOX

GEARBOX GEAR	MINIMUM PE HOSE ON GROUND REELING IN SPEED (m/hr)	MAXIMUM PE HOSE ON GROUND REELING IN SPEED (m/hr)
I	0	20
II	20	40
III	40	70
IV	70	UNLIMITED

2-SPEED GEARBOX

GEARBOX GEAR	MINIMUM PE HOSE ON GROUND REELING IN SPEED (m/hr)	MAXIMUM PE HOSE ON GROUND REELING IN SPEED (m/hr)
I	0	50
II	50	UNLIMITED

SUMMARY TABLE OF THE POSITIONS OF MOVEMENT AND CONTROL PARTS DURING OPERATION

OPERATING STAGE	PTO	RELEASE LEVER	BRAKE BELT	RATCHET	GEAR LEVER
PAYING OUT	DISCONNECTED	STOP (0)	BRAKES	LIFTED	GEAR IN
IRRIGATION	DISCONNECTED	START (1)	DOES NOT BRAKE	IN POSITION (RATCHETS)	GEAR IN
GEAR CHANGE (DOES NOT APPLY TO SINGLE SPEED GEARBOXES)	DISCONNECTED	LEVER ON START (1) AND BYPASS OPEN	DOES NOT BRAKE	IN POSITION (HOLDS THE ROLLER STILL)	SELECT GEAR
QUICK REELING IN THROUGH PTO	CONNECTED	STOP (0)	DOES NOT BRAKE	IN POSITION (RATCHETS)	GEAR IN

5	USE OF THE MACHINE
PAR.	DESCRIPTION
4	Turning off

4. TURNING OFF



Machine operator: operator authorised to use the machine (strictly following the manufacturer's instructions) in compliance with the laws in force in the machine user's country.



Mechanical maintenance technician: skilled technician, able to operate the machine in normal conditions, to act on mechanical parts to perform the required adjustments, maintenance and repairs. **Typically, they are not authorised to perform operations on live electrical systems.**



Manufacturer's technician: skilled technician, provided by the manufacturer to perform operations of a complex nature in special situations or however agreed with the user. As the case may be, their skills are mechanical, electrical or electronic.



While turning off the self-propelled machine, follow this procedure:

- 1) upon reaching the end of irrigation, the limit stop bracket placed on the PE hose hits the bar joint and disengages the gearbox;
- 2) after that, one must turn off the pumping station and disconnect the hose from the line.

If the machine is fitted with inlet (fig. 5.4.1) or drain (fig. 5.4.2) water valve (both optional features), when the limit stop bracket disengages the gearbox, the inlet water valve closes or the drain valve opens through installation of a 3-way cock (also connected to the gear release lever).

In any case (inlet or drain), at the end of irrigation the pumping station stops, if fitted with pressure switch, due to over-pressure or under-pressure. It is very important to assess the distance between the pumping unit and the machine, to understand whether the water valves are able to produce over-pressure or under-pressure).

(fig. 5.4.1)

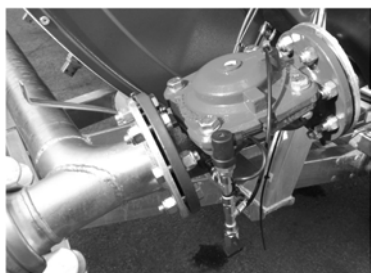

(fig. 5.4.2)

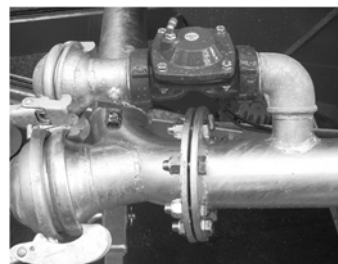

WATER VALVE	START	END OF IRRIGATION
INLET	OPEN	CLOSES
DRAIN	CLOSES	OPEN

- 3) Lift the spades and boom feet (where present) of the machine from the ground:
- carefully act on the distributor lever (B) (fig. 5.1.2), after connecting it to the hydraulic system (through quick couplings to the tractor or through a diesel or petrol engine etc.) to lift the spades until they reach the stroke end; with this operation to lift the spades, the trolley loader is also lifted, and the trolley hitched to it (fig. 5.4.3);

(fig. 5.4.3)



- where present, lift the boom feet from the ground, by removing then placing back the pin and cotter, so that the machine can be rotated (fig. 5.4.4);

(fig. 5.4.4)

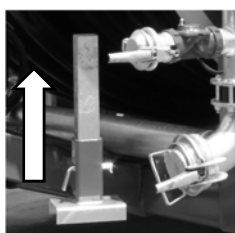

- 4) if the machine had been initially rotated, move the turbocar back in the towing position, by carefully using the distributor lever (B) (fig. 5.1.2) after connecting it to the hydraulic system (through quick couplings to the tractor or through a diesel or petrol engine etc.) (fig. 5.4.5);

(fig. 5.4.5)

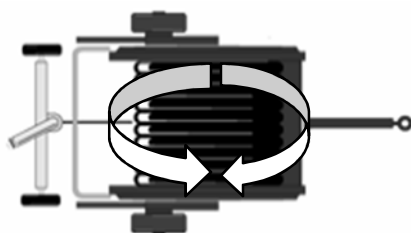

! PAY ATTENTION DURING ROTATION OF THE TURBOCAR TO ENSURE THE QUICK COUPLING PIPES (IF ANY), DO NOT GET ENTANGLED OR HOOKED INTO PARTS OR COMPONENTS OF THE MACHINE, CAUSING THEM TO BREAK;

- 5) lower the drawbar lifter foot/feet and the wheels (lift the machine) in order to be able to hitch the machine to the tractor; in this operation it is required to:
 - a) lift the turbocar, lowering the wheels and the drawbar lifter foot or feet, using the distributor lever (B) after connecting it to the hydraulic system (through quick couplings to the tractor or through a diesel or petrol engine etc.) in order to be able to connect the machine to the tractor (fig. 5.4.6);

(fig. 5.4.6)



- b) if present, connect the lights bar and braking systems to the tractor;

The machine is now ready to be hitched to the tractor (fig. 5.4.6).

! If the compressor is fitted on the machine (optional feature in some machine models) and you wish to partially empty the PE hose from water, this operation must be performed before hitching the machine to the tractor;

The compressor kit (fig. 5.4.7) consists of:

- compressor (I);
- system (L) consisting of rubber hose with fitting and check valve (as an alternative it is possible to have a rigid iron system);

(fig. 5.4.7)

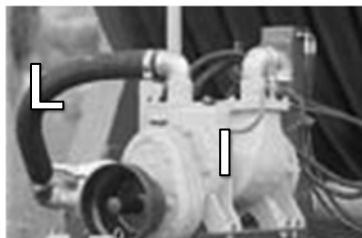

! BEFORE STARTING THE COMPRESSOR CAREFULLY READ THE USER AND MAINTENANCE MANUAL PROVIDED WITH IT;

! IT IS FORBIDDEN TO START UP THE PTO BEFORE COMPLETING AND CHECKING INSTALLATION OF THE COMPRESSOR;

⚠ TO DO SO ASCERTAIN THAT:

- THE CARDAN SHAFT BETWEEN TRACTOR AND COMPRESSOR IS CORRECTLY SIZED FOR THE POWER TO BE TRANSMITTED, IS PROPERLY CONNECTED (THE SAFETY PINS MUST BE HOUSED IN THE APPROPRIATE SEAT ON THE PTO) IS PROPERLY POSITIONED (MAXIMUM SLOPE = 10°) AND IS FITTED WITH GUARDS;

- THE DRAIN CAP OF THE IRRIGATOR TROLLEY HAS BEEN REMOVED (fig. 5.4.8);

(fig. 5.4.8)

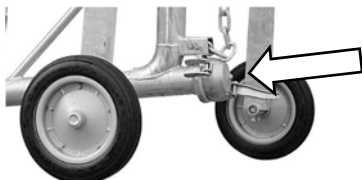

- THE COMPRESSOR'S SYSTEM HAS BEEN PROPERLY CONNECTED TO THE MACHINE'S SYSTEM, ENSURING ALL HOOKS OF THE FITTING ARE PROPERLY INSERTED (fig. 5.4.9) (THIS DOES NOT APPLY TO THE RIGID IRON SYSTEM);

(fig. 5.4.9)

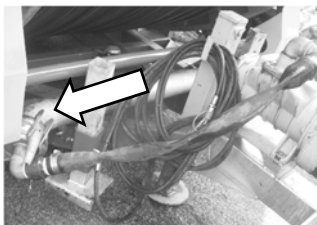

- THE SECOND INLET IS CLOSED WITH THE CAP SUPPLIED (fig. 5.4.10);

(fig. 5.4.10)



- IF WATER VALVES ARE FITTED ON THE MACHINE (OPTIONAL FEATURE), ENSURE IT IS OPEN (INLET) OR CLOSED (DRAIN);

- CHECK THE OIL LEVELS IN THE GEAR BLOCK (M) AND IN THE BLADE TANK (N) (fig. 5.4.11);

(fig. 5.4.11)

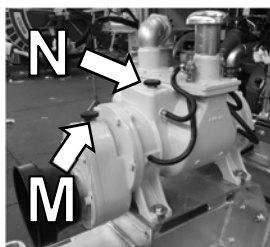

(fig. 5.4.12)

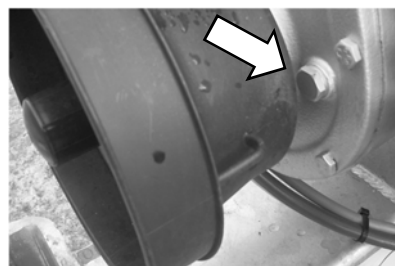

COMPRESSOR PART	OIL	LEVEL
GEAR BLOCK (M)	SAE90	UP TO THE LEVEL SCREW (fig. 5.4.12)
BLADE TANK (N)	SAE20, 15W40	FULL UP TO THE CAP

- ONCE THE COMPRESSOR IS AT OPERATING SPEED (540 RPM), ENSURE ONE DROP OF OIL PER SECOND COMES DOWN IN THE OIL REGULATOR(S) FITTED ON IT (THIS SYSTEM LUBRICATES THE BLADES INSIDE THE COMPRESSOR); TO ADJUST USE THE KNOB (O) (fig. 5.4.13);

(fig. 5.4.13)

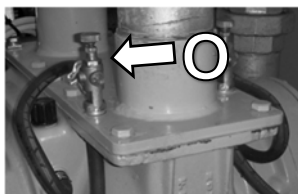

DO NOT STAND NEAR THE COMPRESSOR DURING ITS OPERATION;

6	MAINTENANCE
PAR.	DESCRIPTION
1	General warnings

1. GENERAL WARNINGS



Machine operator: operator authorised to use the machine (strictly following the manufacturer's instructions) in compliance with the laws in force in the machine user's country.



Mechanical maintenance technician: skilled technician, able to operate the machine in normal conditions, to act on mechanical parts to perform the required adjustments, maintenance and repairs. **Typically, they are not authorised to perform operations on live electrical systems.**



Manufacturer's technician: skilled technician, provided by the manufacturer to perform operations of a complex nature in special situations, or however agreed with the user. As the case may be, their skills are mechanical, electrical or electronic.



These instructions are indicative as they may change according to weather conditions, type and work environment therefore they are subject to changes that may only be established by the operator's common sense and experience.

However, accurate maintenance remains a crucial factor for proper operation of the machine. Neglecting this aspect may be a source of hazard for people and property as well as for the turbocar, obviously.

Normal periodic maintenance and daily checks must be performed according to a preset schedule following the instructions in the use and maintenance booklets of individual components. For proper operation and service life of the turbocar, with continued good performance over time, the maintenance requirements set out in the respective manuals of the individual components must be strictly complied with.



UNSCHEDULED MAINTENANCE, REPAIRS AND SPECIAL CALIBRATIONS MUST BE PERFORMED BY SKILLED AND AUTHORISED PERSONNEL.

A service card must be prepared scheduling the various operations to be performed, in which the operating hours, operations, refuelling, maintenance and repairs performed must be recorded every day.

6	MAINTENANCE
PAR.	DESCRIPTION
2	Maintenance

2. MAINTENANCE



Machine operator: operator authorised to use the machine (strictly following the manufacturer's instructions), in compliance with the laws in force in the machine user's country.



Mechanical maintenance technician: skilled technician, able to operate the machine in normal conditions, to act on mechanical parts to perform the required adjustments, maintenance and repairs. **Typically, they are not authorised to perform operations on live electrical systems.**



Manufacturer's technician: skilled technician, provided by the manufacturer to perform operations of a complex nature in special situations or however agreed with the user. As the case may be, their skills are mechanical, electrical or electronic.



Maintenance refers to all operations to check and maintain the perfect condition of the various machine components. Said operations must be performed on the machine periodically (fig. 6.2.1 + tab. 6.2.1).

(tab. 6.2.1)

POS.	DESCRIPTION	TO BE CARRIED OUT		
		EVERY 3 IRRIGATION S	EVERY 20 IRRIGATION S	AT THE END AND START OF THE IRRIGATING SEASON
1	CHECK GEARBOX OIL LEVEL (SAE90)		X	X
2	GREASE THE TURNTABLE			X
3	GREASE DRAWBAR LIFTING FOOT (IF MECHANICAL-MANUAL)			X
4	GREASE SEAL (WATER INLET ON ROLLER)	X		X
5	GREASE ROLLER SWIVEL SUPPORTS		X	X
6	GREASE SLIDING BAR CHAIN		X	X
7	GREASE ROLLER CROWN GEAR AND GEARBOX PINION		X	X
8	GREASE THE WHOLE LENGTH OF THE SLIDING BAR, BAR SUPPORTS, SLIDING BLOCK AND PAWL		X	X
9	GREASE BEARINGS OF THE MACHINE'S WHEEL SUPPORTS		X	X
10	CHECK TYRE PRESSURE		X	X
11	GREASE THE REAR PARKING EXTENSIONS		X	X
12	GREASE THE VERTICAL EXTRACTING RODS AND THE INTERNAL TROLLEY LOADER			X
13	CHECK SMOOTH SLIDING OF BYPASS LEVERS (WHERE ANY) AND GEAR			X
14	GREASE THE TURNTABLE CROWN GEAR AND MOTOR PINION (IF ACCES. HYDRAULIC SLEWING)		X	X
15	CHECK BATTERY (WHERE ANY)			X
16	CHECK CONTROL UNIT, CONTROL UNIT SYSTEM AND ACCESSORIES SUCH AS FLASHING LIGHT, LIGHT BAR (WHERE ANY)			X
17	CHECK COMPRESSOR OIL (SAE90 GEARBOX BLOCK - 15W40 OR SAE20 BLADE TANK) (IF ANY)		X	X
18	GREASE BEARINGS OF IRRIGATOR TROLLEY WHEELS		X	X
19	GREASE IRRIGATOR AND SECONDARY IRRIGATOR (IF ANY) (SEE APPROPRIATE USE AND MAINTENANCE MANUAL)			

(fig. 6.2.1)

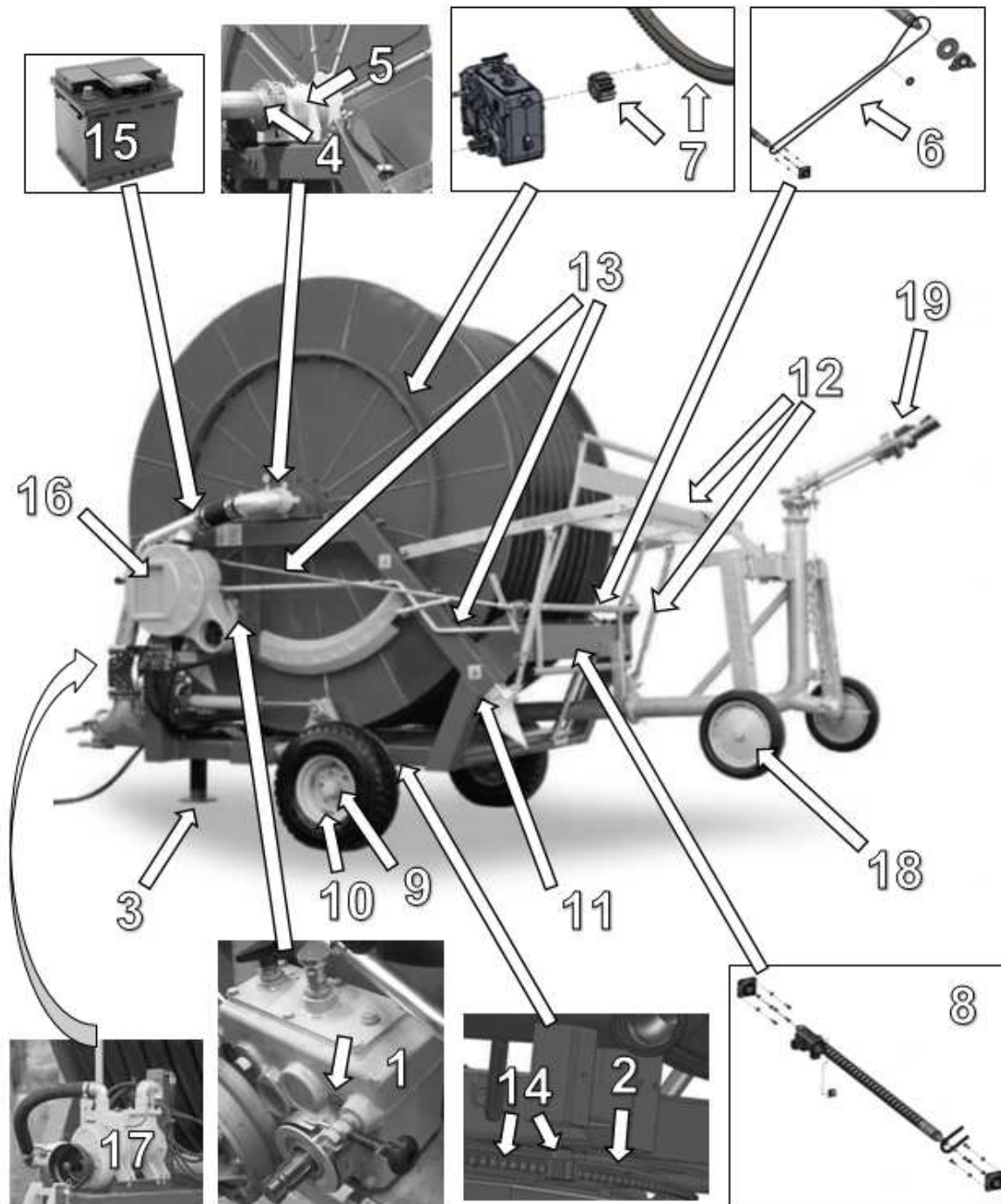

7	SPARE PARTS AND ACCESSORIES
PAR.	DESCRIPTION
1	Support

1. SUPPORT

Please do not hesitate to contact the manufacturer for any type of information on the use, maintenance, installation etc. of the Machine.
The Customer should ask questions in clear terms, with references to this Manual and the instructions provided.

7	SPARE PARTS AND ACCESSORIES
PAR.	DESCRIPTION
2	Spare parts

2. SPARE PARTS

Contact the manufacturer for any spare part.
ALWAYS USE ORIGINAL SPARE PARTS.



Note.
Idrofoglia S.r.l. shall not be liable for breakdowns, malfunctions or damage to persons or property arising from use of non original parts.

Using non original spare parts is recommended against, and should this happen, Warranty conditions shall be forfeited (if still in force) as well as the Manufacturer's Liability in using the Machine/System and any deriving damage to persons or property.

SPARE PARTS AND ACCESSORIES

8	SUPPLEMENTARY INSTRUCTIONS
----------	-----------------------------------

PAR.	DESCRIPTION
1	Waste disposal

1. WASTE DISPOSAL

The user is responsible for ensuring waste is properly disposed of according to the laws in force in their country.

Disposal of replaced parts must be carried out in compliance with the regulations in force in the country where the Machine is used.

8	SUPPLEMENTARY INSTRUCTIONS
----------	-----------------------------------

PAR.	DESCRIPTION
2	Decommissioning and dismantlement

2. DECOMMISSIONING AND DISMANTLEMENT

All decommissioning and dismantlement operations must be performed after detaching the battery supply cord (if any).

After that, the following operations must be performed:

- Emptying any accessories (if any) from the relevant fluids;
- Disconnecting the electrical cables of the main panel and removing all machine wires (if any);
- Disassembly of trolley and irrigator;
- Disassembly of hose and roller;
- Disassembly of every component that may be manually handled.

The following materials must be sorted and stored for possible recovery or disposed of in compliance with environmental regulations:

- Ferrous metal materials;
- Copper electrical materials;
- Plastic materials.

Any disposal of these or other components or ancillary fluids (starter battery, ancillary cleaning material such as oily rags etc.) must be carried out according to the regulations in force at the time of demolition. For proper disposal, use specialised services authorised to collection and processing or contact the competent authorities for places and methods.
The manufacturer may be contacted as an alternative.



IN ANY CASE DO NOT DISCARD IN THE ENVIRONMENT.

8	SUPPLEMENTARY INSTRUCTIONS
PAR.	DESCRIPTION
3	Safe work procedures

3. SAFE WORK PROCEDURES

Set up specific procedures and adequately inform employees on:

- Safe use of the machine;
- Emergency situations.

DATE OF THE OPERATION	CHECKS OR WORKS PERFORMED	WORKSHOP	OPERATOR (legible signature)

SUPPLEMENTARY INSTRUCTIONS