

GSP03 PERFORMANCE CURVE

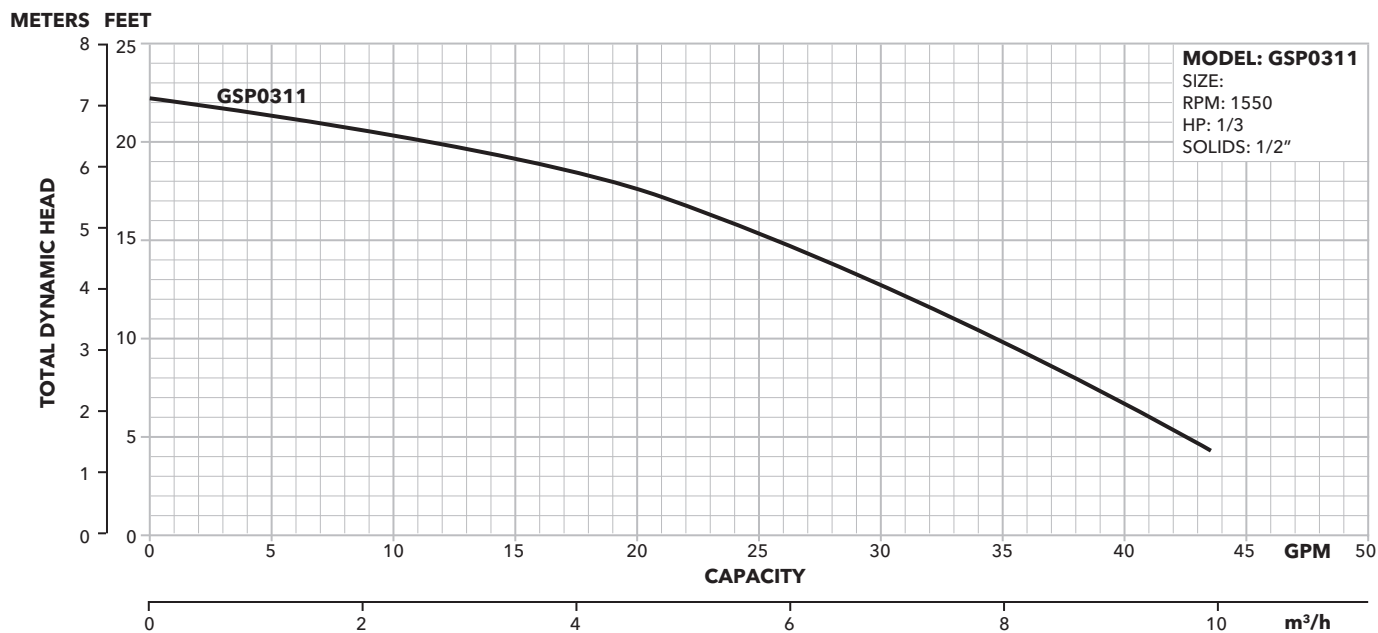

MODEL INFORMATION

Model	Part No.	HP	Volts	Amps	Minimum Circuit Breaker	Phase	Float Switch Style	Cord Length	Discharge Connection	Min. On Level	Min. off Level	Min. Basin Diameter	Max. Solids Size	Shipping Weight
GSP	GSP0311	1/3	115	10	15A	1	Vertical	9'	1 1/2"	7 1/4"	3 1/2"	1'	1/2"	27 lbs
GSP	GSP0311M	1/3	115	10	15A	1	Not Supplied	9'	1 1/2"	-	-	1'	1/2"	27 lbs

COMPONENTS

Item No.	Description
1	Float Bracket
2	Float Rod
3	Float
4	Base
5	Seal Housing
6	Plug
7	Motor Dome
8	Mechanical Switch Housing
9	Handle

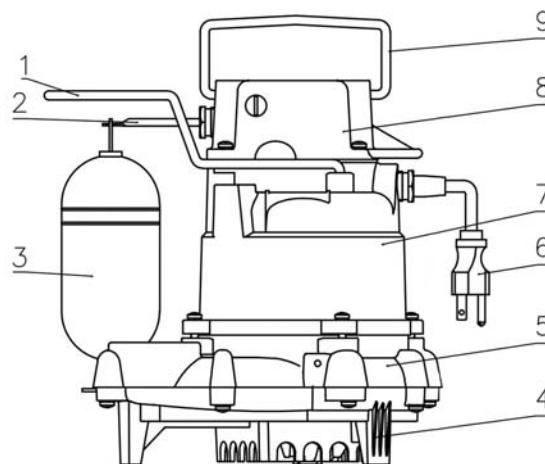

DIMENSIONS

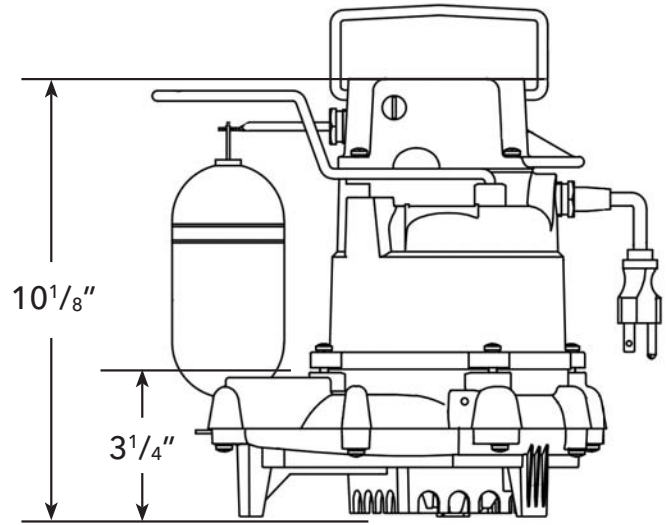
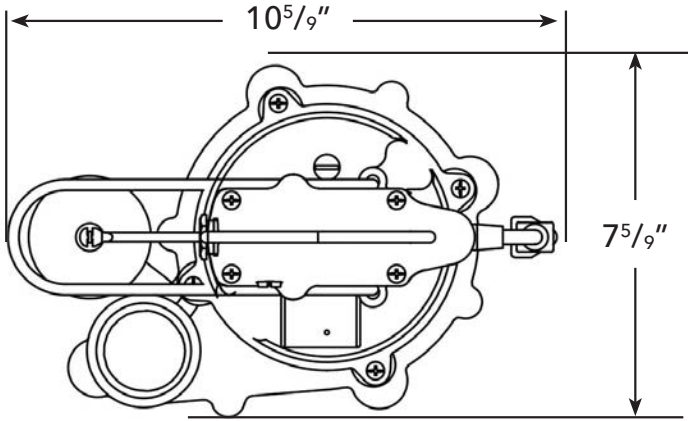

REPAIR PARTS

Part Description	Part No.	Part
GSP-SWITCH	9K701	Switch Assembly with Gasket and Hardware

xylem
Let's Solve Water

Xylem Inc.
2881 East Bayard Street Ext., Suite A
Seneca Falls, NY 13148
Phone: (866) 325-4210
Fax: (888) 322-5877
www.gouldswatertechnology.com

Goulds is a registered trademark of Goulds Pumps, Inc. and is used under license.
© 2016 Xylem Inc. BGSP03 R1 January 2016