



AVAILABLE MOUNTING CONFIGURATIONS

5H-CC CLOSE COUPLED
5H-VM VERTICAL CLOSE COUPLED

OPERATING LEVELS

MIN FLOW	460 GPM	104.5 m ³ /h
MAX FLOW	1890 GPM	429.3 m ³ /h
DISCHARGE SIZE	5"	127 mm
SUCTION SIZE	8"	203.2 mm
SOLIDS HANDLING	.97"	2.5 cm
MAX SPEED	1800 RPM	1800 RPM
SHUT-OFF HEAD	265'	80.8 m
BEP HEAD	220'	67 m
BEP FLOW	1460 GPM	331.6 m ³ /h
BEP PERCENT	83%	83%



A typical picture of the pump is shown. Please contact Cornell Pump Company for further details. All information is approximate and for general guidance only.

PARTS	CAST IRON BRONZE FITTED (STANDARD)	ALL IRON
IMPELLER	BRONZE SAE 40 OR SILICON BRONZE	CAST IRON ASTM A48 CL30
VOLUTE	CAST IRON ASTM A48 CL30	CAST IRON ASTM A48 CL30
SHAFT	CARBON STEEL	CARBON STEEL
SHAFT SLEEVE	BRONZE SAE 660	416 STAINLESS STEEL
MOTOR	ODP W/ 1.15 SF	ODP W/ 1.15 SF
WEAR RINGS	BRONZE SAE 660	CAST IRON ASTM A48 CL30
SUCTION SPOOL	CAST IRON ASTM A48 CL30	CAST IRON ASTM A48 CL30
BACKPLATE	CAST IRON ASTM A48 CL30	CAST IRON ASTM A48 CL30
MECHANICAL SEAL (OPTIONAL)	T-1, BUNA, CARBON/CERAMIC/STAINLESS	T-1, BUNA, CARBON/CERAMIC/STAINLESS
PACKING	GRAPHITED ACRYLIC	GRAPHITED ACRYLIC

The 5HH pump is designed with Cornell's renowned quality and durability. It features a 5" discharge, 8" suction, enclosed impeller, and flanged tangential double volute. Available in all-iron or bronze-fitted materials. Graphited acrylic packing is standard, with Cornell's patented Cycloseal® available (with type 1 single mechanical seal). Optional motors include TEFC (other options available).

- Standard cast iron bronze fitted construction
- External hydraulic balance line
- Double volute construction
- Back pullout design
- Replaceable hub & suction wear rings
- Replaceable shaft sleeve
- "Shower curtain shield" bearing protection
- High efficiency hydraulics
- Low operating costs
- Two year warranty
- Other mechanical seal (Cycloseal®) and material options available



AGRICULTURE



FOOD



INDUSTRIAL



MINING



MUNICIPAL



OIL & GAS



REFRIGERATION



RENTAL

5H-CC

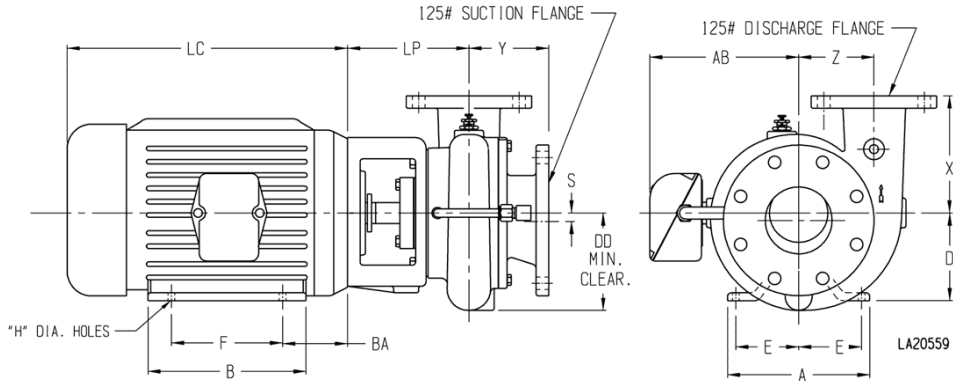

PUMP DIMENSIONS										
MODEL	CONNECTION		DISCH. INCR.	AK DIM.	DD	S	X	Y	Z	LP
	DISCH.	SUCT.								
2.5H	2.5	4	90°	8.5	9.62	0.44	11	8.28	7.75	7.66
				12.5	9.62	0.44	11	8.28	7.75	7.66
3HA	3	6	90°	12.5	11.12	0.44	10	8.53	8.5	10.09
3HC	3	6	90°	12.5	11.12	0.44	10	8.53	8.5	10.09
4HC	4	8	90°	12.5	12.62	0.88	11	10.88	9.75	11.19
4HH	4	6	90°	12.5	15	0.44	9.5	8.97	11.25	10.12
5H	5	8	90°	12.5	14.75	0.88	13	9.66	11.62	10.15
				16.5	16.25	0.44	11	10.56	10.25	10.81
5HH	5	8	90°	12.5	16.25	0.44	11	10.56	10.25	10.81
				16.5	14.75	0.44	14	10.18	11.62	10.12
6H	6	8	90°	12.5	14.75	0.44	14	10.18	11.62	10.12
				16.5	14.75	0.44	14	10.18	11.62	10.12
6HH	6	8	90°	12.5	17.12	0.44	12	10.43	12	11.13
				16.5	17.12	0.44	12	10.43	12	11.13
8H	8	10	90°	12.5	16.75	0.75	13	10.41	11.5	11.38
				16.5	16.75	0.75	13	10.41	11.5	11.38

MOTOR DIMENSION										
MOTOR FRAME	AK DIM.	A	B	D	E	F	H	AB	BA	LC
213-5	8.5	9.5	8	5.25	4.25	7	0.41	7.94	4.5	13.69
254-6	8.5	11.25	11.25	6.25	5	10	0.53	9.5	5	17.94
284-6	12.5	12.25	12.25	7	5.5	11	0.53	11.37	5	21.31
324-6	12.5	14.25	13.75	8	6.25	12	0.66	12.22	5.5	22.19
364-5	12.5	15.75	14	9	7	12.25	0.66	13.2	6.12	24.31
404-5	12.5	18.5	16.62	10	8	13.75	0.81	16.39	6.88	29.97
444-5	16.5	21.5	19.5	11	9	16.5	0.81	19.06	7.5	31

