

UNIT FOR CONTROL AND PROTECTION OF IRRIGATION MOTOR PUMPSET

TYPE **CIM-250**

INSTRUCTION AND USER MANUAL



MOUNTING AT PANEL

- By simply starting, it automatically controls the motor pump
- Pump water electronic pressure gauge
- Digital pump water pressure gauge
- Assembly also on the machine and in the open air.

MADE TO:

PROTECT

motor pump sets by stopping them in the event of:

- low oil pressure
- over-temperature
- belt breakage
- minimum fuel level
- low coolant level
- low pump water pressure
- pump water overpressure
- A1 available

DISPLAY

on the panel the functions of:

- hour-meter
- oil pressure gauge
- water or oil thermometer
- tachometer
- pump water pressure gauge
- timer
- fuel level gauge
- pump protection exclusion
- battery and oil lights
- protections intervention
- emergency stop

PARMA



ELCOS[®]

ITALY

BRIEF INSTRUCTIONS

After starting, the motor pump protects itself automatically

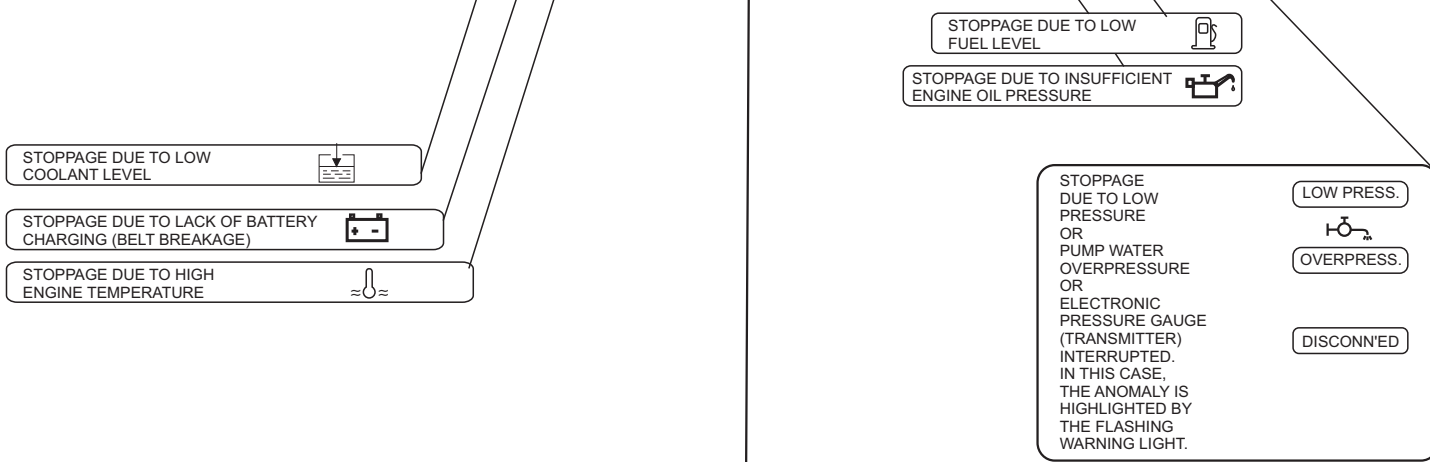
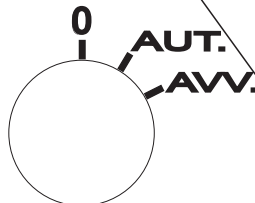
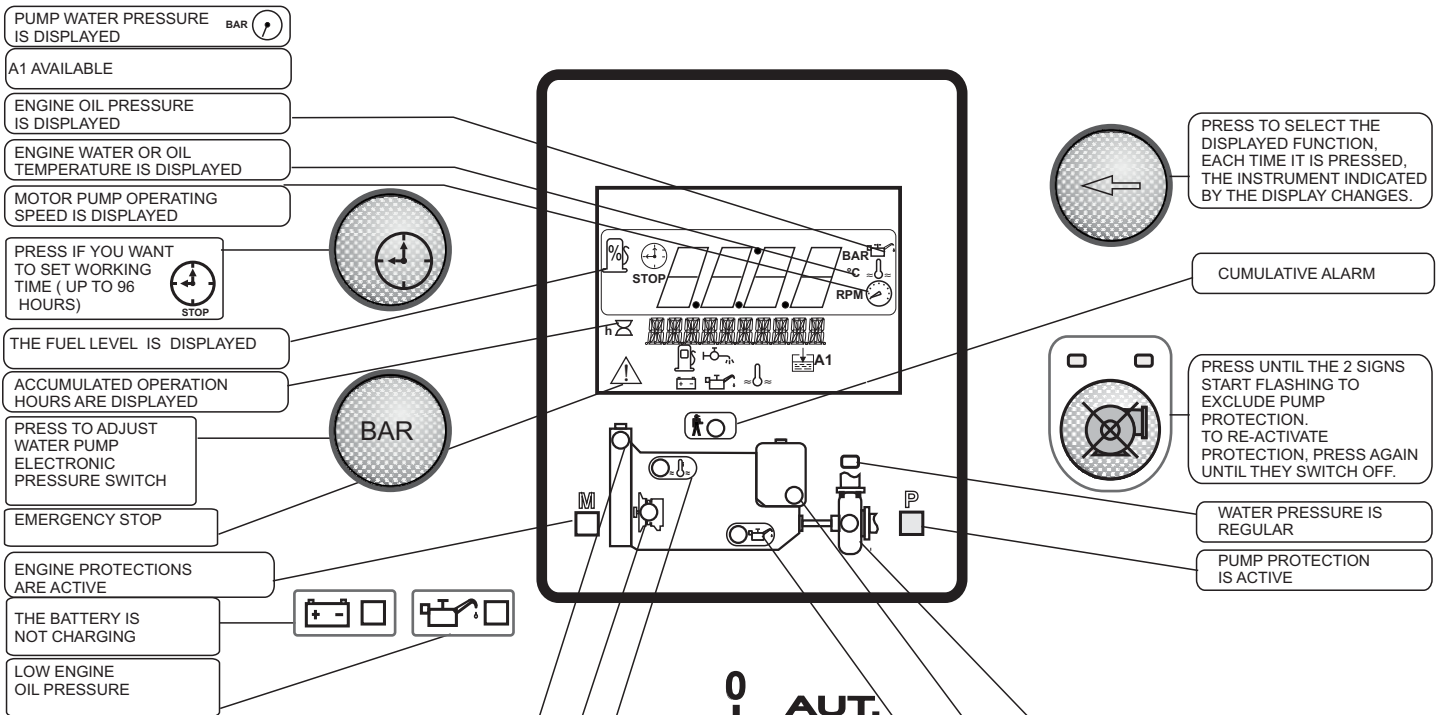

START KEY

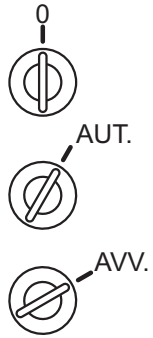

- OFF
- STOPPAGE IN ALL OPERATING CONDITIONS
- RESTORE PROTECTIONS, CANCEL PUMP PROTECTION EXCLUSION AND TIMER, DEACTIVATE INSTRUMENTS.
- CONTROL UNIT SUPPLY
- TURNS ALL THE LIGHTS ON FOR 2 SECONDS (EFFICIENCY CHECK)
- PRESSURE SWITCH ADJUSTING (SEE PAGE 3)
- MOTOR PUMP START UP

ADJUSTING THE PUMP WATER ELECTRONIC PRESSURE GAUGE (TRANSMITTER)

It controls the pressure of the system, replacing the conventional pressure switch.

PUMP PROTECTION

No adjusting is required

The **protection of the pump** is enabled when the PUMP PROTECTION ACTIVE  information comes on, after the water pressure has been steady for 2 consecutive minutes and in any case after 10 minutes from starting of the engine.

Intervention of the protection occurs 5 seconds after the pressure goes up or down by **two bars**, stops the engine and is shown on the display:



OVERPRESS.

Pump water overpressure

or

LOW PRESS.

Low pressure (low pressure)

It is possible to change the **two bars** of the **pressure lowering** (low pressure) by using the key . This change is cancelled when the engine stops.

OVERPRESSURE remains set to two bars, this value is added to the working pressure (for example, working pressure 9 bar overpressure 11 bar)

WORKING PRESSURE

Press to adjust the value of low pressure (PRESSOSTAT)

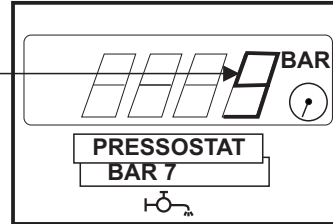

Press to select the pump water pressure gauge

TIMER

Enabled with key on "AUT", it makes it possible, if necessary, to have the motor pump work for an adjustable length of time (96 hours maximum), at the end of which it stops and the WORK TIME OVER  sign lights up on the display.

The work time is set by pressing the push-button  ( lights up) until the desired value appears on the DISPLAY .

On releasing the push-button, the timer automatically starts working, continuously displaying the remaining work time.

CANCELLING THE SET TIME

To zeroing the set time there are two methods:

- keep the push-button  pressed until it reaches zero.

- by turning the starter key onto "ZERO" (the engine pump will stop).

PUMP PROTECTION EXCLUSION (ENABLED ONLY WITH ENGINE RUNNING)

The push-button  excludes pump protection:

- exclusion is obtained by keeping it pressed for at least 3 consecutive seconds; the function is indicated by the two intermittent lights .

- this exclusion is cancelled by pressing the push-button, again or by turning the start key onto "ZERO".

OIL AND BATTERY INDICATOR LIGHTS





Lit up with key on "AUT", they switch off with the engine running and regular oil pressure and battery charge system.

ENGINE PROTECTIONS

The engine protections are enabled when the ENGINE PROTECTIONS ACTIVE light  comes on (20 seconds after the end of starting impulse and however 1 minute after positioning the key on "AUT").

Interventions of the protection probes (fitted on the engine), indicated by the relevant lights, stop the engine, they are memorised and can be split into two groups.

Delayed by 2 seconds for:

- OIL PRESSURE SWITCH 
- OVERTEMPERATURE SWITCH 

Delayed by 5 seconds for:

- A1
- BATTERY CHARGE ALTERNATOR (ALTERNATOR BELT BREAKAGE)
- FUEL LEVEL SWITCH
- Fuel reserve flashing signal: 20% fuel reserve (T) (WITHOUT ENGINE STOP)
- Signal always on: stop for minimum fuel level (W)



- PROBE FOR COOLANT LEVEL

INSTALLING THE CONTROL UNIT

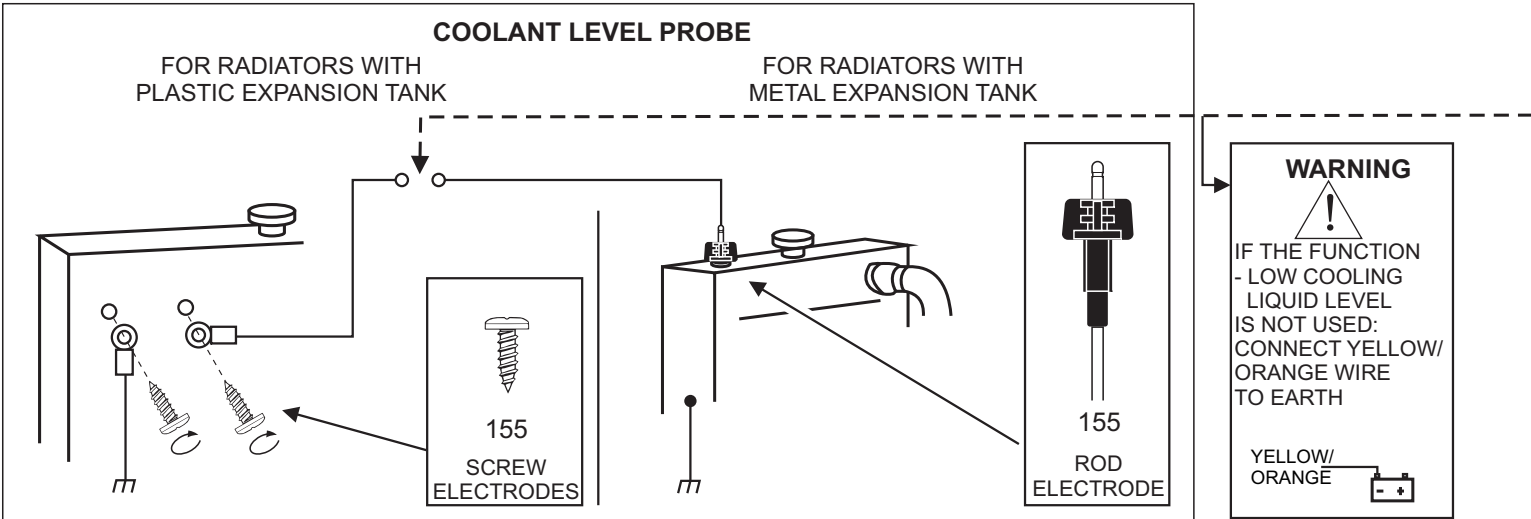

TO REPLACE THE FUSES, REMOVE THE COVER FROM THE CONTROL UNIT



The control unit has been designed to control stopping with an ELECTROMAGNET

STOP SYSTEM SET UP
To stop with the **SOLENOID VALVE** cut and isolate the **BLUE/BROWN** lead

- SET UP**
- WATER OR OIL THERMOMETER
 - OIL PRESSURE GAUGE

To view the water/oil THERMOMETER and the oil pressure GAUGE, connect the transmitters to the respective wires of the control unit, then CUT and isolate the BLACK/VIOLET wire

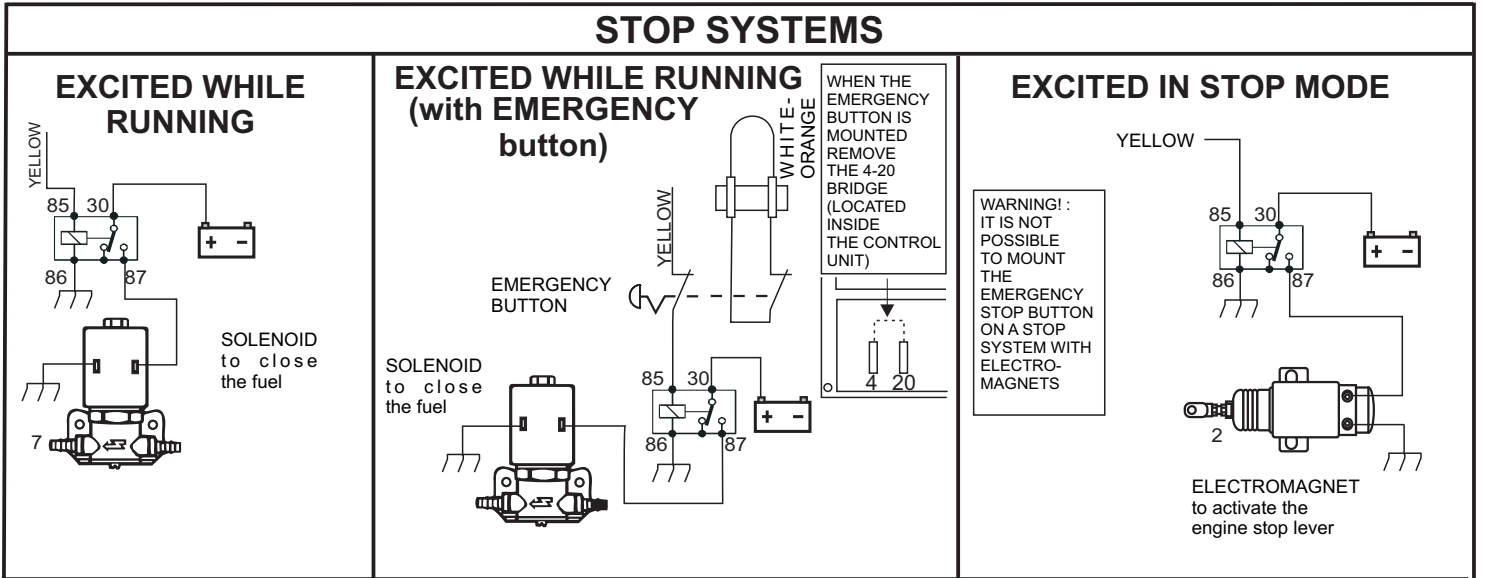

TACHOMETER ADJUSTMENT

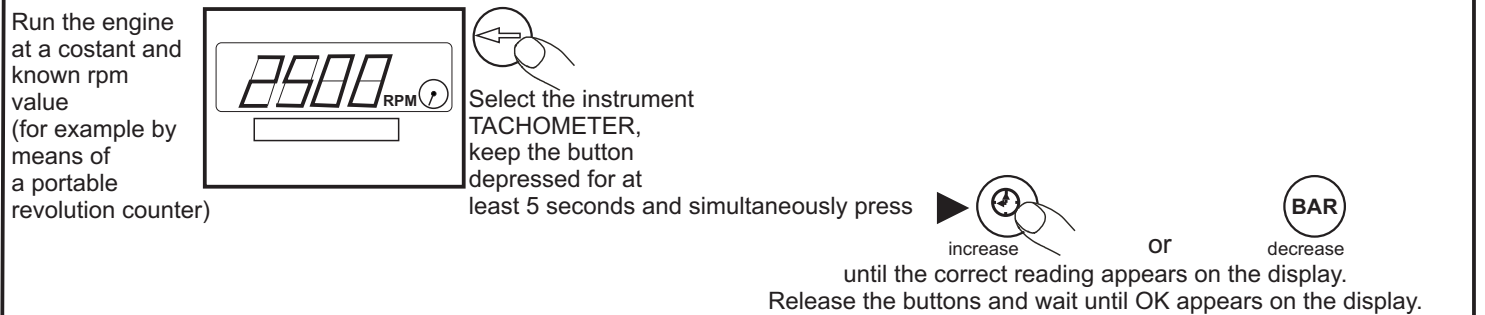

INSTALLING THE CONTROL UNIT

WIRING DIAGRAM

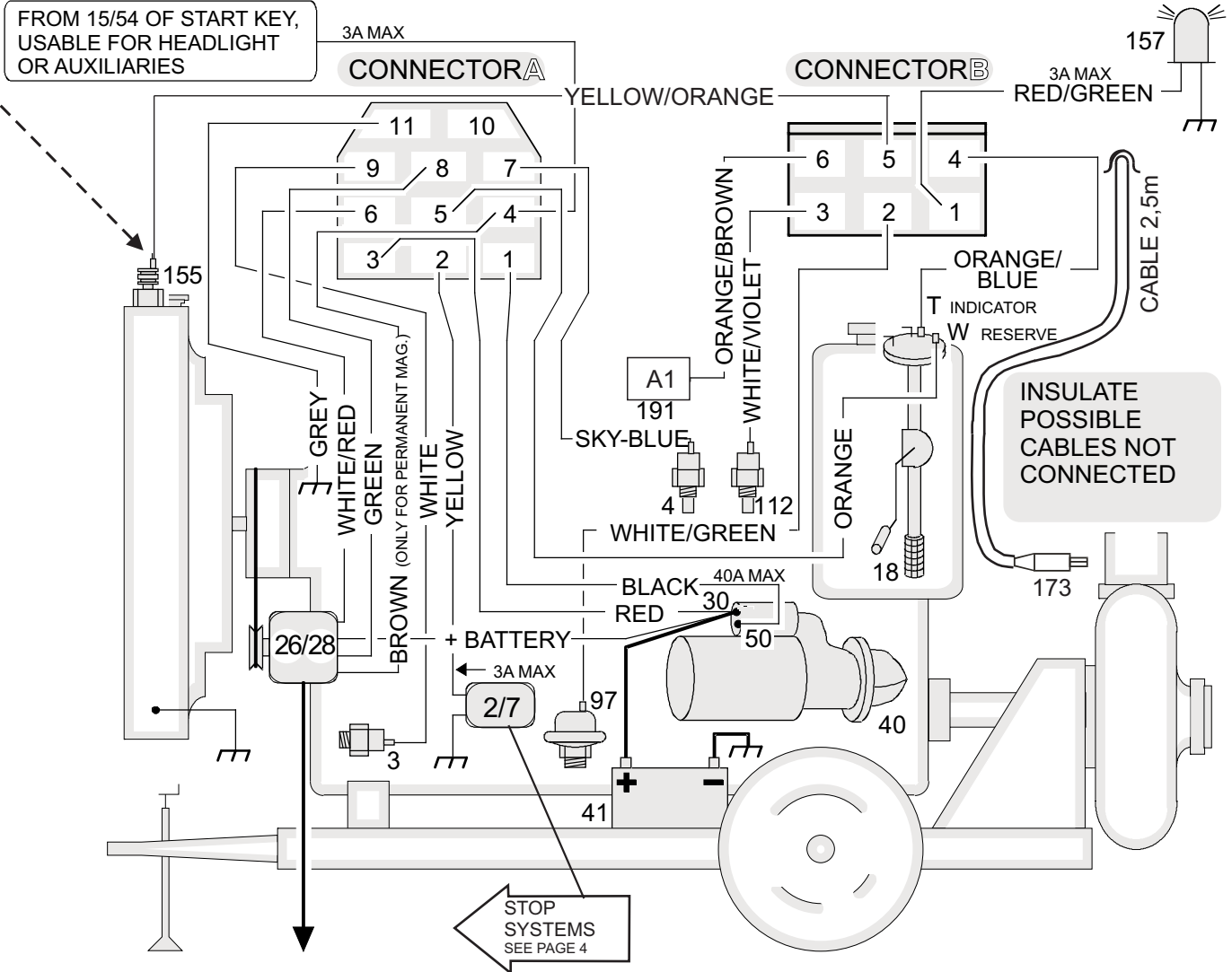

CHARGE BATTERY ALTERNATOR:

PRE-EXCITATION

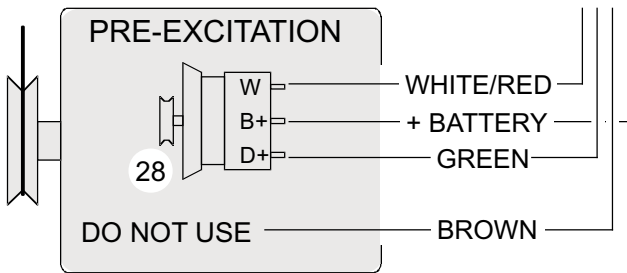

PERMANENT MAGNETS

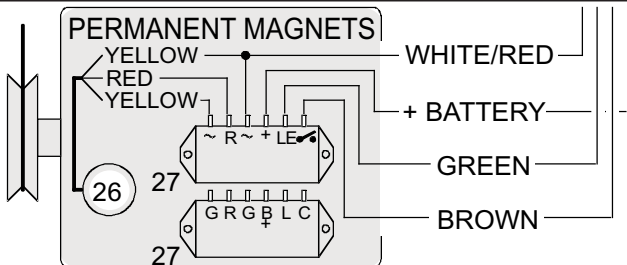

ACCESSORIES AVAILABLE ON REQUEST

- (2/7) ELECTROMAGNET OR SOLENOID VALVE
- (3) OIL PRESSURE SWITCH
- (4) THERMOSTAT
- (18) FUEL FLOAT FOR INDICATOR AND RESERVE
- (97) OIL PRESSURE TRANSMITTER
- (112) TEMPERATURE TRANSMITTER
- (155) COOLANT LEVEL PROBE
- (173) PUMP WATER PRESSURE TRANSMITTER (SUPPLIED)

- (26) PERMANENT MAGNETS CHARGE ALTERNATOR
- (27) BATTERY CHARGE ALTERNATOR REGULATOR
- (28) PRE-EXCITATION CHARGE ALTERNATOR
- (40) STARTING MOTOR
- (41) BATTERY
- (157) GENERAL ALARM LIGHT
- (191) A1 AVAILABLE FOR PROTECTION PROBE

CONNECTION SYSTEM FOR EXTRACTING THE W TERMINAL IN PRE-EXCITATION BATTERY CHARGE ALTERNATORS.

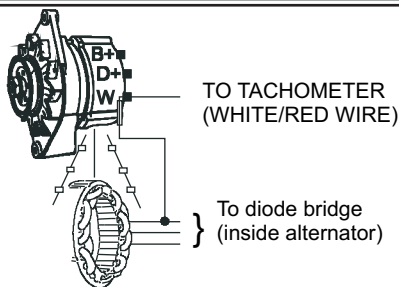

(BOSCH, MARELLI, LUCAS, ECC...)

SELECT LANGUAGE The language set up is ITALIAN; the languages that can be selected are: ENGLISH, FRENCH, GERMAN, SPANISH and PORTUGUESE.

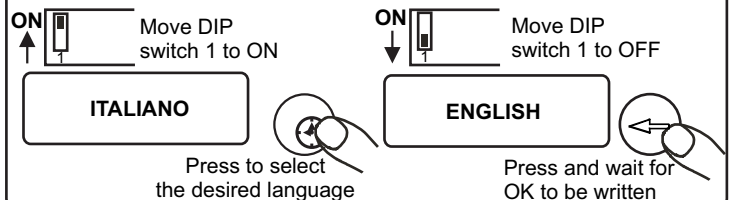

OPERATION

CONTROLLING THE CONNECTION OF THE PUMP WATER ELECTRONIC PRESSURE GAUGE (Transmitter)

Turning the key to the AUT position stops the electronic pressure gauge.

Control is activated 1 minute after the completion of the starting pulse.

Intervention is highlighted by the relevant indicators and stops the motor pump after 2 seconds.

DISCONNECTED



flashing warning light



To exclude intervention, press the push-button



PUMP PROTECTION EXCLUSION.

PUMP PROTECTION

The pump protection is enabled with the switching on of the ACTIVE PUMP PROTECTION (after 2 consecutive minutes of stable water pressure, indicated by the visual signal REGULAR PUMP PRESSURE  and, in any case, 10 minutes after the start of the motor pump).

The intervention of the protection (5 seconds after the increase or decrease of the pressure) stops the engine and is indicated by the visual signal for WATER PUMP OVERPRESSURE  or LOW PUMP WATER PRESSURE .

RESET: is obtained by turning the start key onto "ZERO".

STOPPING THE ENGINE PUMP

The control unit shuts down the engine in four conditions:

- turning the starter key onto "ZERO"
- protection intervention
- timer intervention at the end of the work period
- through intervention of the external emergency.

The unit adapts to two different stop systems

- by working the ELECTROMAGNET for 20 seconds which pulls the STOP lever
- by cutting off power to the SOLENOID VALVE shutting off the flow of fuel.

GENERAL ALARM



This can be obtained by fitting on the outside an optical and/or acoustic signaller to be connected to the RED/GREEN wire. It is activated on protection intervention.

EMERGENCY STOP

It can be obtained in all functioning conditions, mounting one or more release-type buttons. It is indicated by the visual signal  and enables the general alarm.

INSTRUMENT SELECTION

The control unit comprises six instruments:

 HOUR METER - Total hours of operation (with the engine running the signal  pulsates, to indicate the correct functioning of the HOUR-METER).

INSTRUMENTS WHICH CAN BE SELECTED IN SEQUENCE BY PRESSING THE BUTTON 

Each time it is pressed, IT SHOWS the next instrument. WHEN THE TIMER IS set, the duration of the display of the instrument is limited to 30 seconds from the activating of the button; the TIMER then reappears.

 - PRESSURE GAUGE - Engine oil pressure

 - THERMOMETER - Engine oil and water temperature

 - TACHOMETER - Speed of motor pump

 - PRESSURE GAUGE - Pump water pressure

 - INDICATOR - Fuel level percentage

} TRANSMITTERS FITTED ON ENGINE
ON REQUEST

UNIT FOR CONTROL AND PROTECTION OF IRRIGATION MOTOR PUMPSET TYPE **CIM-250**

Only for starting and surveillance of the diesel motor pump and stops it if there are anomalies in the parts controlled by probes.
It has been designed to be installed also on the machine.

NOTICES



Warning:
adhere closely to the following advice:

- Always install under other equipment which produces or spreads heat.
- Always follow the Wiring Diagram on pages 4-5 when making connections.
- Check that the line loading and the consumption of the connected equipment are compatible with the technical characteristics on page 8.
- All technical interventions must be performed with the engine stationary and terminal 50 of the starter motor disconnected.
- Never use a battery charger for the emergency start-up, this could damage the control unit.
- To protect the safety of persons and the equipment, before connecting an external battery charger, disconnect the electrical plant terminals from the battery poles.
- Never disconnect the battery terminals with the engine running.

THIS CONTROL UNIT IS NOT SUITABLE FOR OPERATING IN THE FOLLOWING CONDITIONS:

- Where the environmental temperature is outside the limits indicated in the Technical Data on page 8.
- Where there are high levels or heat from radiation caused by the sun, ovens or the like.
- Where there is the risk of fire or explosions.
- Where the panel can receive strong vibrations or knocks.

ELECTROMAGNETIC COMPATIBILITY

This control unit functions correctly only if inserted in plants which conform with the CE marking standards; it meets the exemption requirements of the standard EN61326-1 but it cannot be excluded that malfunctions could occur in extreme cases due to particular situations. The installer has the task of checking that the disturbance levels are within the requirements of the standards.

CONDUCTION AND MAINTENANCE

The following maintenance operations should be performed every week:

- check that the indicators function;
- check the batteries;
- check that the conductors are tight, check the condition of the terminals.

UNLESS WE MAKE A WRITTEN DECLARATION STATING THE CONTRARY, THIS CONTROL UNIT IS NOT SUITABLE FOR USE AS A CRITICAL COMPONENT IN EQUIPMENT OR PLANTS RESPONSIBLE FOR KEEPING PERSONS OR OTHER LIVING BEINGS ALIVE

YOUR ELECTRICAL TECHNICIAN CAN ASK US ANYTHING ABOUT THIS CONTROL UNIT BY TELEPHONING ONE OF OUR TECHNICIANS

DIMENSIONS

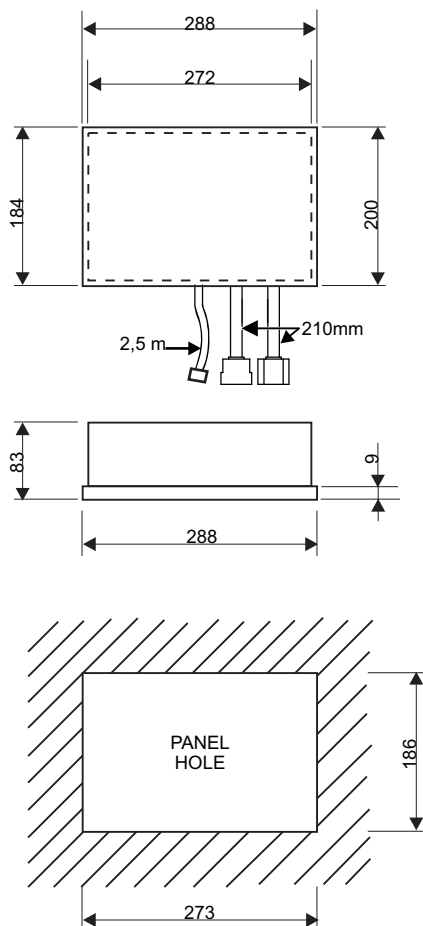

TECHNICAL DATA

- BATTERY VOLTAGE SUPPLY	12 Vdc 24 Vdc
- VOLTAGE SUPPLY	8÷ 32V
- CIRCUIT LOADING WITH KEY AT ZERO	13 mA at 12 V 9 mA at 24 V
- MAX LOAD OF THE OUTPUT:	
- (STOPPING) YELLOW	3 A
- (STARTING MOTOR) BLACK	40 A
- (GENERAL ALARM) RED/GREEN	3 A
- (AUXILIARY) BROWN	3 A
- TEMPERATURE RANGE	-10 ÷ +60 °C
- HOUR-METER	4 DIGITS
- OIL PRESSURE GAUGE	0 ÷ 7 bar
- PUMP WATER PRESSURE GAUGE	0 ÷ 21 bar
- PUMP WATER PRESSURE TRANSMITTER:	
• ALLOWED MAX. PRESSURE	21 bar
- ENGINE OIL/WATER THERMOMETER	+20 ÷ +145 °C
- TACHOMETER	4000 rpm
- TIMER	1' ÷ 24 h
- INSTALLATION CONDITIONS	FOR EXTERNAL USE
- DEGREE OF PROTECTION:	
BOX/CONNECTOR	IP54/IP20
- CONTROL UNIT WEIGHT	1,5 Kg
- TOTAL WEIGHT	3,2 Kg
(CONTROL UNIT + ACCESSORIES + PACKAGE)	

ORDERING DATA

TYPE CIM-250 CODE 00211056

ACCESSORIES KIT

- PRE - WIRED FEMALE CONNECTOR CEM-256	CODE 70804382
- PUMP WATER PRESSURE TRANSMITTER TYPE TPA-200	
NIPPLE F1/4" GAS -M3/8"GAS	CODE 40500251
- NUTS KIT	CODE 40179906

CONFORMITY DECLARATION



The company Elcos s.r.l. assumes full responsibility for declaring that the control unit:

Type **CIM-250**

installed and used in the ways and for the purposes described in the user instruction manual complies with the essential requirements and other relevant provisions laid down by the following directives:

- 2004/108/CE related to the electromagnetic compatibility and that repeals the directive 89/336/CEE,
- 2011/65/UE on the restriction of the use of certain hazardous substances in electrical and electronic equipment,

because it is built and functions in accordance with the harmonized Standards: EN61326-1, EN61326/A1, EN61000-4-2, EN61000-4-4, EN61000-4-6, EN60529.

E ELCOS® S.r.l.
Via Arandora Star, 28/a
I 43122 PARMA ITALIA
Tel. +39 0521/772021 Fax +39 0521/270218
E-mail: info@elcos.it - HTTP://www.elcos.it

Parma, 30/01/2013
President

Margini Enzo