



Type "B" Single Stage Centrifugal Pump Electric Motor Drive

Section	CC
Page	350.1
Date	July 1, 2011
Supersedes 1/1/04	

CAST IRON IMPELLER

B6ZPL

Flanged Case

Packing Construction

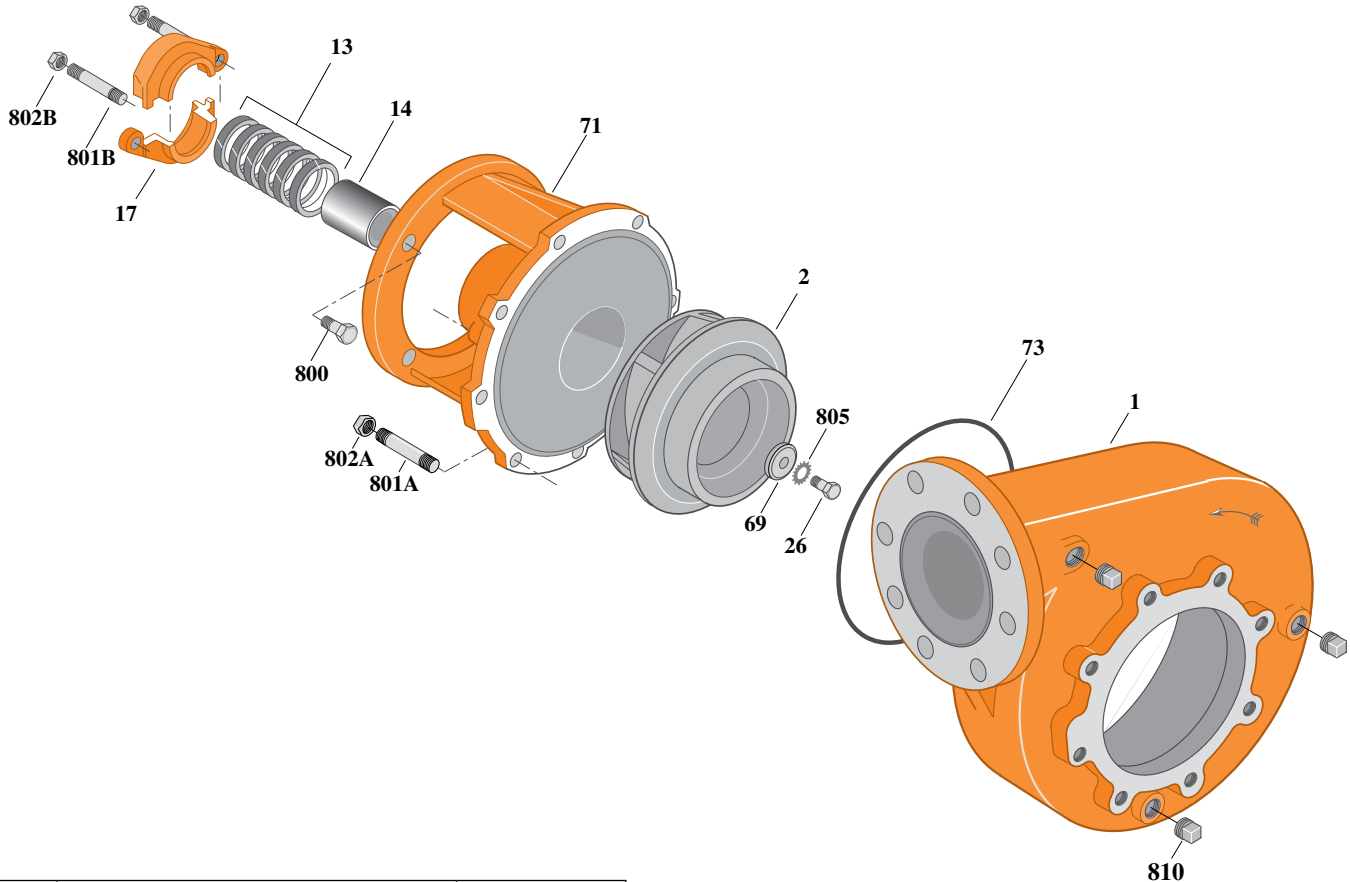

Item	Part Description	Part Number
1	Case, Volute	H05065
2	Impeller	See Table I
13	Rings, Packing (Set of 6)	S13470
14	Sleeve, Shaft	S05149L
17	Gland, Packing	B82470
26	Screw, Impeller 1/2 - 13 x 3"	S23631
32	Key, 1/4 x 2-1/4" (See Note 1)	S23677
69	Washer, Impeller	S06319
71	Bracket	See Table II
73	O-Ring (See Note 2)	M14943
800	Capscrew, 1/2 - 13 x 1-1/2" (4 Req.)	S26916
801A	Stud, 3/8 - 16 x 1-3/8" (8 Req.)	S09942
801B	Stud, 3/8 - 16 x 4" (2 Req.)	S08303
802A	Nut, Hex 3/8 - 16 (8 Req.)	S23103
802B	Nut, Hex 3/8 - 16 (2 Req.)	S23343
805	Washer, Lock	S23038
810	Plug, Pipe 1/2 NPT (3 Req.)	S23717

Table I

B/M No.	HP	PH	RPM	"U" Dim.	Imp. Dia.	Imp. No.
B69509	10	1	1800	1-1/4"	6.12"x8.25"	M07718
B69512	10	3	1800	1-1/4"	6.12"x8.25"	M07718
B69548	15	3	1800	1-1/4"	7.56"x8.56"	M07719
B69542	20	3	1800	1-1/4"	8.00"x9.00"	M04348

Table II

HP	PH	Bracket No.	"AK" Fit	"U" Dim.	Motor Frame
10	1	L03827	8-1/2"	1-1/4"	215JP
10	3	L03827	8-1/2"	1-1/4"	215JP
15	3	L03827	8-1/2"	1-1/4"	254JP
20	3	L03827	8-1/2"	1-1/4"	256JP

NOTE 1: For an explanation of the tabulated material found on this page and for impeller key location, refer to *Supplement A* located at the beginning of this section.

NOTE 2: Also accepts gasket S05126 as replacement for o-ring. See *Supplement E* located at the beginning of this section.



Type "B" Single Stage Centrifugal Pump Electric Motor Drive

Section	CC
Page	350.2
Date	July 1, 2011
Supersedes 1/1/04	

CAST IRON IMPELLER

B6ZPLS

Flanged Case

Mechanical Shaft Seal Construction

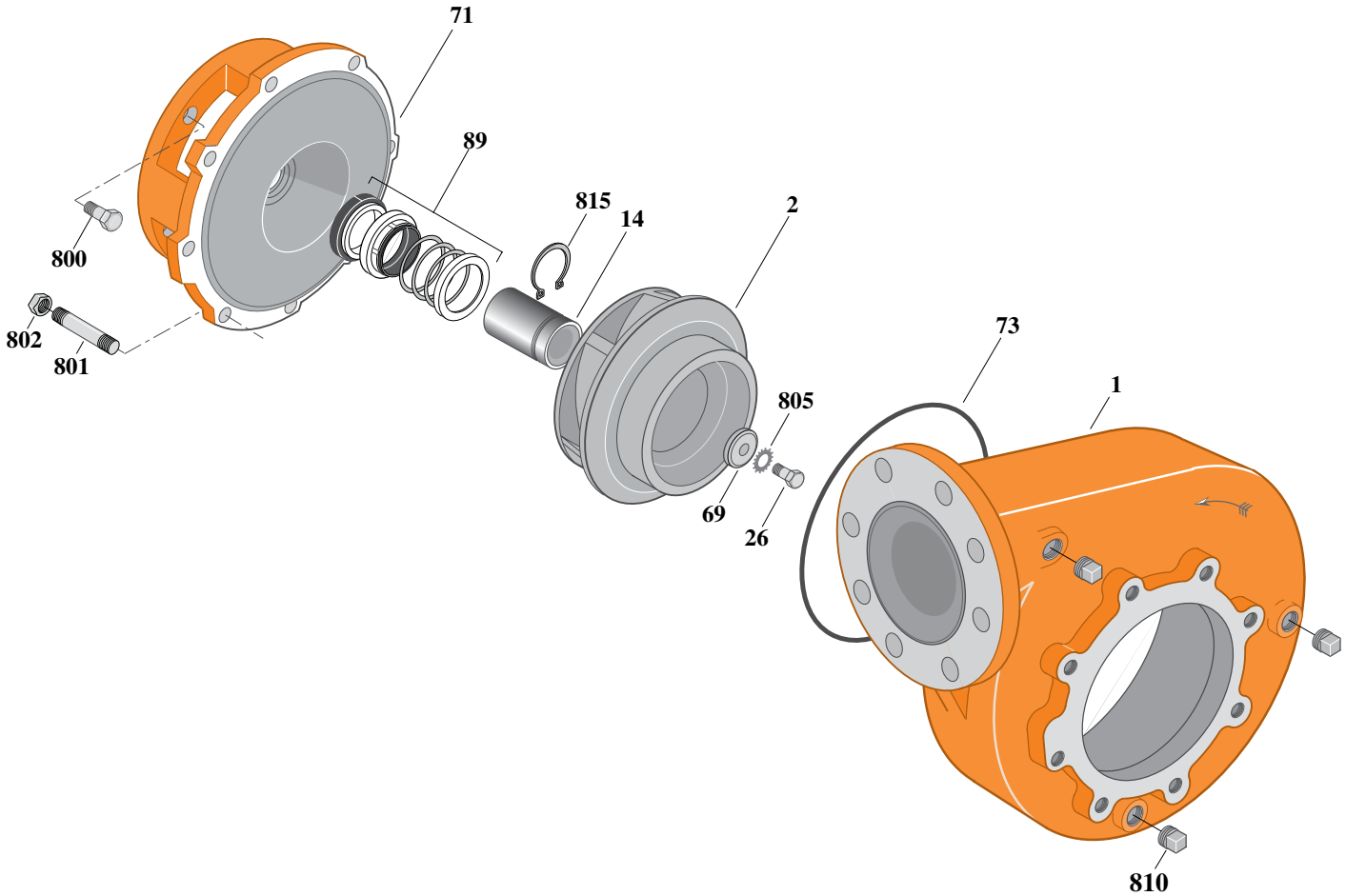

Item	Part Description	Part Number
1	Case, Volute	H05065
2	Impeller	See Table I
14	Sleeve, Shaft	S19310L
26	Screw, Impeller 3/8 - 16 x 2"	S23574
32	Key, 3/16 x 1-1/4" (See Note 1)	S34383
69	Washer, Impeller	S06314
71	Bracket	See Table II
73	O-Ring (See Note 2)	M14943
89	Seal, Mechanical Shaft	S32014
800	Capscrew, 1/2 - 13 x 1" (4 Req.)	S26912
801	Stud, 3/8 - 16 x 1-3/8" (8 Req.)	S09942
802	Nut, 3/8 - 16 (8 Req.)	S23103
805	Washer, Lock	S23036
810	Plug, Pipe 1/2 NPT (3 Req.)	S23717
815	Ring, Retaining	S11207

Table I

B/M No.	HP	PH	RPM	"U" Dim.	Imp. Dia.	Imp. No.
B69514	10	1	1800	7/8"	6.12"x8.25"	M07766
B69515	10	3	1800	7/8"	6.12"x8.25"	M07766

Table II

HP	PH	Bracket No.	"AK" Fit	"U" Dim.	Motor Frame
10	1	L05331	8-1/2"	7/8"	215JM
10	3	L05331	8-1/2"	7/8"	215JM

NOTE 1: For an explanation of the tabulated material found on this page and for impeller key location, refer to *Supplement A* located at the beginning of this section.

NOTE 2: Also accepts gasket S05126 as replacement for o-ring. See *Supplement E* located at the beginning of this section.



Type "B" Single Stage Centrifugal Pump Electric Motor Drive

Section	CC
Page	350.2.1
Date	July 1, 2011
Supersedes 1/1/04	

CAST IRON IMPELLER

B6ZPLS

Special Flanged Case

Mechanical Shaft Seal Construction

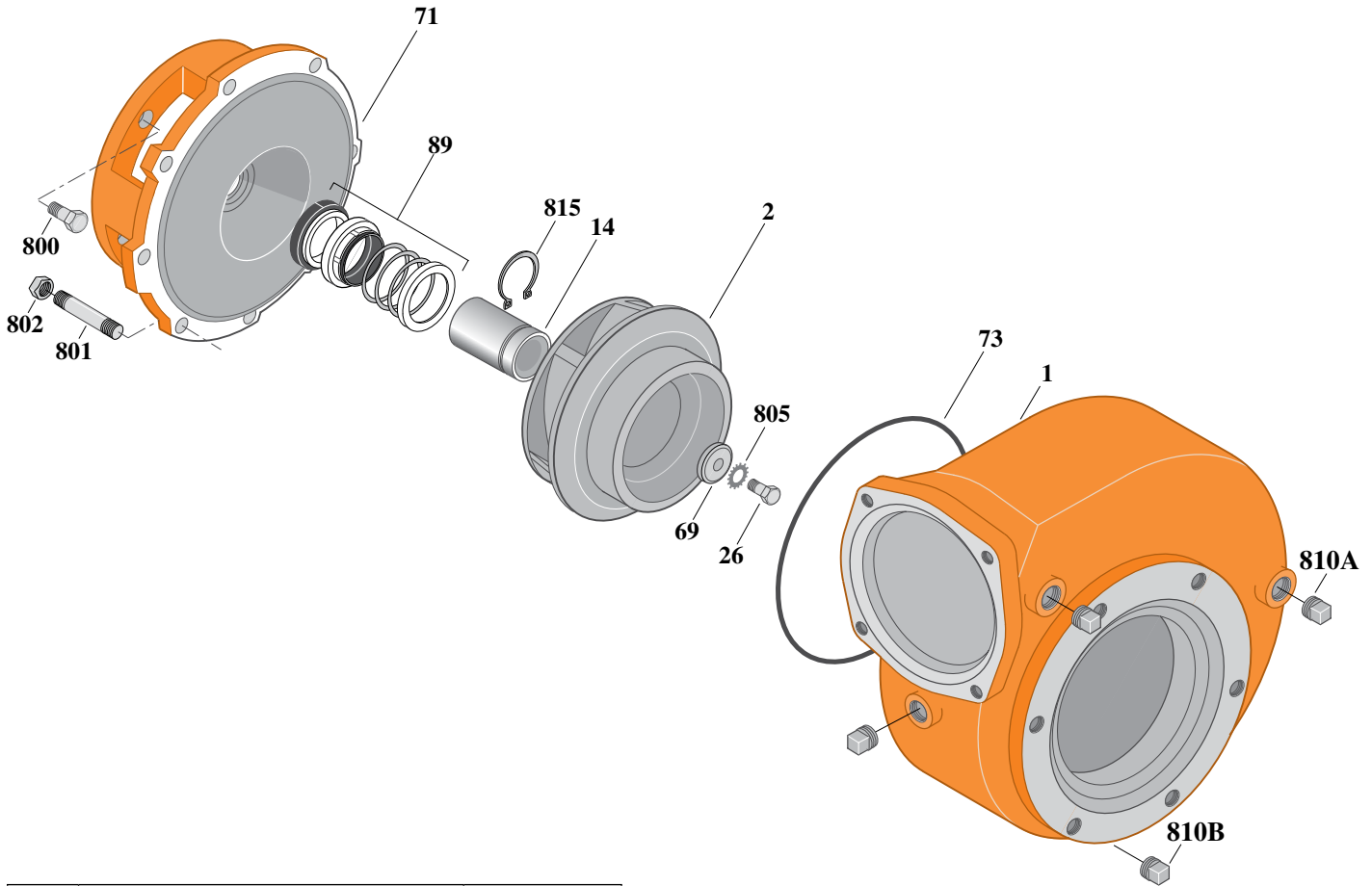

Item	Part Description	Part Number
1	Case, Volute	H01750
2	Impeller	See Table I
14	Sleeve, Shaft	S19310L
26	Screw, Impeller 3/8 - 16 x 2"	S23574
32	Key, 3/16 x 1-1/4" (See Note 1)	S34383
69	Washer, Impeller	S06314
71	Bracket	See Table II
73	O-Ring (See Note 2)	M14943
89	Seal, Mechanical Shaft	S32014
800	Capscrew, 1/2 - 13 x 1" (4 Req.)	S26912
801	Stud, 3/8 - 16 x 1-3/8" (8 Req.)	S23994
802	Nut, 3/8 - 16 (8 Req.)	S23103
805	Washer, Lock	S23036
810A	Plug, Pipe 1/2 NPT (3 Req.)	S23717
810B	Plug, Pipe 1/2 NPT Skt. Hd.	M11137
815	Ring, Retaining	S11207

Table I

B/M No.	HP	PH	RPM	"U" Dim.	Imp. Dia.	Imp. No.
B56350	10	1	1800	7/8"	6.12"x8.25"	M07766
B56351	10	3	1800	7/8"	6.12"x8.25"	M07766

Table II

HP	PH	Bracket No.	"AK" Fit	"U" Dim.	Motor Frame
10	1	L05331	8-1/2"	7/8"	215JM
10	3	L05331	8-1/2"	7/8"	215JM

NOTE 1: For an explanation of the tabulated material found on this page and for impeller key location, refer to **Supplement A** located at the beginning of this section.

NOTE 2: Also accepts gasket S05126 as replacement for o-ring. See **Supplement E** located at the beginning of this section.



Type "B" Single Stage Centrifugal Pump Electric Motor Drive

Section	CC
Page	350.3
Date	July 1, 2011
Supersedes 1/1/04	

CAST IRON IMPELLERB6ZPLS

Flanged Case

Mechanical Shaft Seal Construction

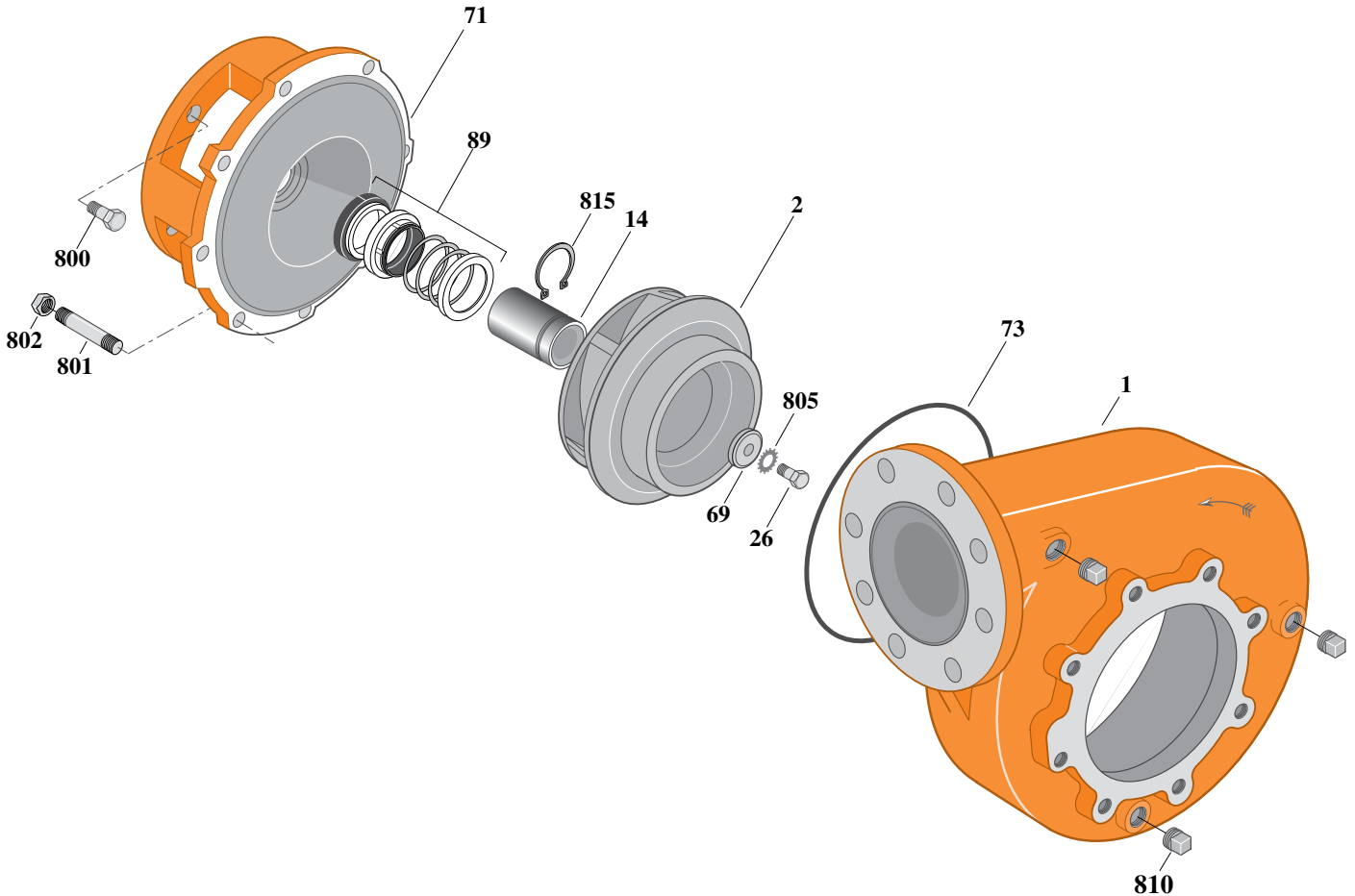

Item	Part Description	Part Number
1	Case, Volute	H05065
2	Impeller	See Table I
14	Sleeve, Shaft	S18869L
26	Screw, Impeller 1/2 - 13 x 3"	S23631
32	Key, 1/4 x 2-1/4" (See Note 1)	S23677
69	Washer, Impeller	S06319
71	Bracket	See Table II
73	O-Ring (See Note 2)	M14943
89	Seal, Mechanical Shaft	S32015
800	Capscrew, 1/2 - 13 x 1" (4 Req.)	S26912
801	Stud, 3/8 - 16 x 1-3/8" (8 Req.)	S09942
802	Nut, 3/8 -16 (8 Req.)	S23103
805	Washer, Lock	S23038
810	Plug, Pipe 1/2 NPT (3 Req.)	S23717
815	Ring, Retaining	S16767

Table I

B/M No.	HP	PH	RPM	"U" Dim.	Imp. Dia.	Imp. No.
B69546	15	3	1800	1-1/4"	7.56"x8.56"	M07719
B69540	20	3	1800	1-1/4"	8.00"x9.00"	M04348

Table II

HP	PH	Bracket No.	"AK" Fit	"U" Dim.	Motor Frame
15	3	L04615	8-1/2"	1-1/4"	254JM
20	3	L04615	8-1/2"	1-1/4"	256JM

NOTE 1: For an explanation of the tabulated material found on this page and for impeller key location, refer to *Supplement A* located at the beginning of this section.

NOTE 2: Also accepts gasket S05126 as replacement for o-ring. See *Supplement E* located at the beginning of this section.



Type "B" Single Stage Centrifugal Pump Electric Motor Drive

Section	CC
Page	350.3.1
Date	July 1, 2011
Supersedes 1/1/04	

CAST IRON IMPELLER

B6ZPLS

Special Flanged Case

Mechanical Shaft Seal Construction

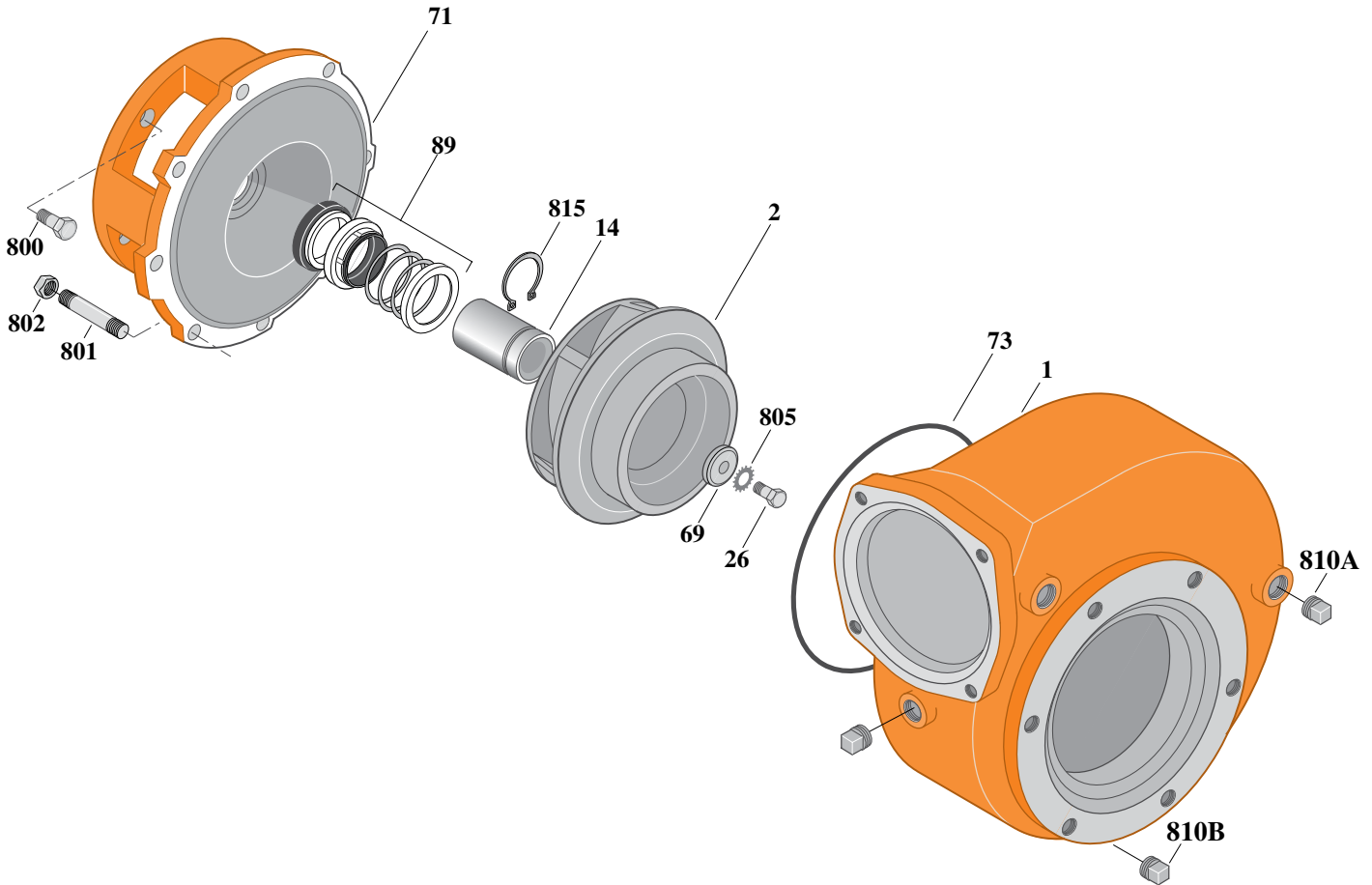

Item	Part Description	Part Number
1	Case, Volute	H01750
2	Impeller	See Table I
14	Sleeve, Shaft	S18869L
26	Screw, Impeller 1/2 - 13 x 3"	S23631
32	Key, 1/4 x 2-1/4" (See Note 1)	S23677
69	Washer, Impeller	S06319
71	Bracket	See Table II
73	O-Ring (See Note 2)	M14943
89	Seal, Mechanical Shaft	S32015
800	Capscrew, 1/2 - 13 x 1" (4 Req.)	S26912
801	Stud, 3/8 - 16 x 1-3/8" (8 Req.)	S23994
802	Nut, 3/8 - 16 (8 Req.)	S23103
805	Washer, Lock	S23038
810A	Plug, Pipe 1/2 NPT (3 Req.)	S23717
810B	Plug, Pipe 1/2 NPT Skt. Hd.	M11137
815	Ring, Retaining	S16767

Table I

B/M No.	HP	PH	RPM	"U" Dim.	Imp. Dia.	Imp. No.
B56352	15	3	1800	1-1/4"	7.56"x8.56"	M07719
B56353	20	3	1800	1-1/4"	8.00"x9.00"	M04348

Table II

HP	PH	Bracket No.	"AK" Fit	"U" Dim.	Motor Frame
15	3	L04615	8-1/2"	1-1/4"	254JM
20	3	L04615	8-1/2"	1-1/4"	256JM

NOTE 1: For an explanation of the tabulated material found on this page and for impeller key location, refer to *Supplement A* located at the beginning of this section.

NOTE 2: Also accepts gasket S05126 as replacement for o-ring. See *Supplement E* located at the beginning of this section.



Type "B" Single Stage Centrifugal Pump Electric Motor Drive

Section	CC
Page	350.4
Date	July 1, 2011
Supersedes 1/1/04	

BRONZE IMPELLER

B6ZPLS

Flanged Case

Mechanical Shaft Seal Construction

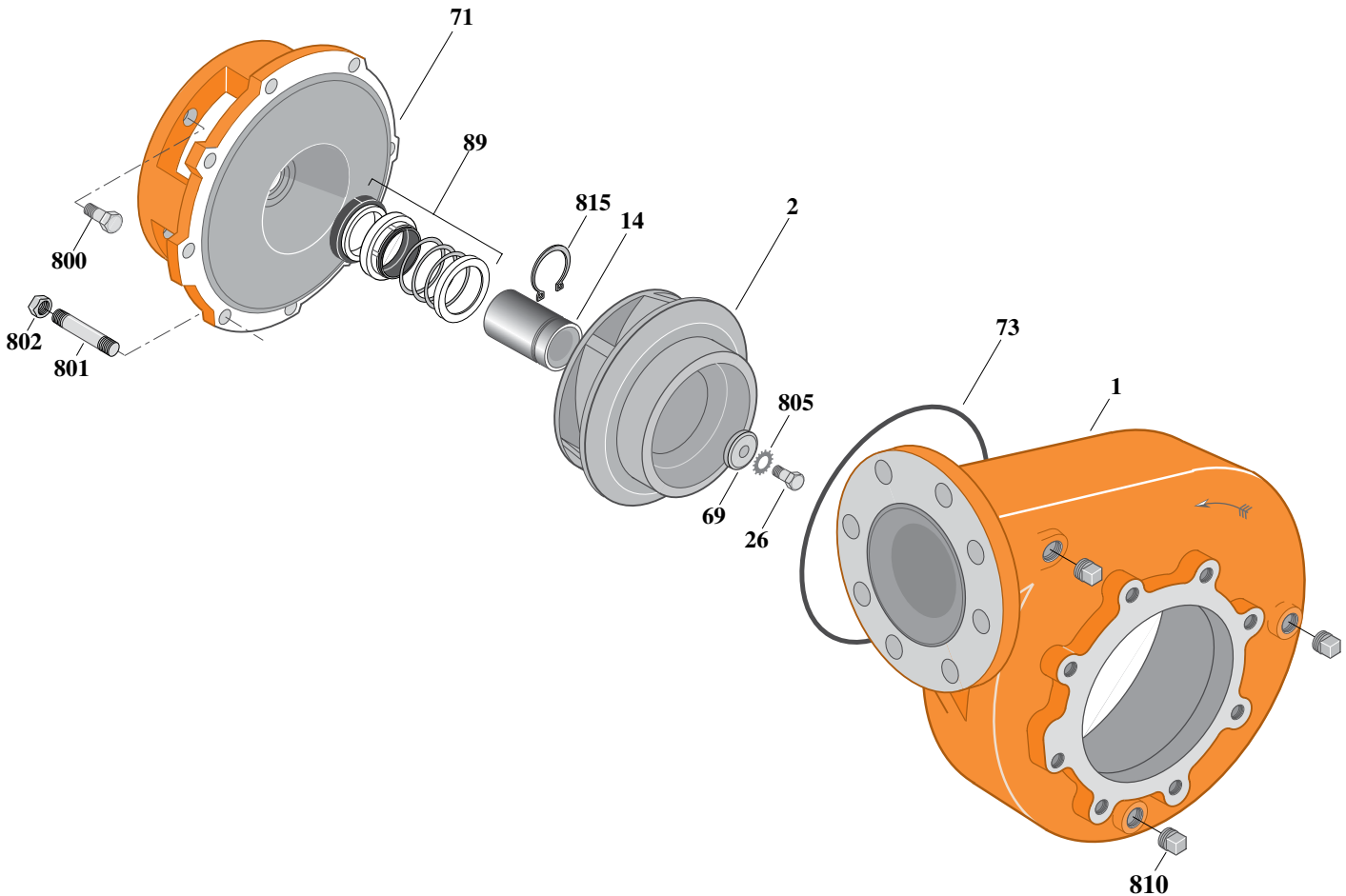

Item	Part Description	Part Number
1	Case, Volute	H05065
2	Impeller	See Table I
14	Sleeve, Shaft	S19310L
26	Screw, Impeller 3/8 - 16 x 2"	S23574
32	Key, 3/16 x 1-1/4" (See Note 1)	S34383
69	Washer, Impeller	S06314
71	Bracket	See Table II
73	O-Ring (See Note 2)	M14943
89	Seal, Mechanical Shaft	S32014
800	Capscrew, 1/2 - 13 x 1" (4 Req.)	S26912
801	Stud, 3/8 - 16 x 1-3/8" (8 Req.)	S09942
802	Nut, 3/8 - 16 (8 Req.)	S23103
805	Washer, Lock	S23036
810	Plug, Pipe 1/2 NPT (3 Req.)	S23717
815	Ring, Retaining	S11207

Table I

B/M No.	HP	PH	RPM	"U" Dim.	Imp. Dia.	Imp. No.
B76777	10	1	1800	7/8"	6.12"x8.25"	M11566
B76778	10	3	1800	7/8"	6.12"x8.25"	M11566

Table II

HP	PH	Bracket No.	"AK" Fit	"U" Dim.	Motor Frame
10	1	L05331	8-1/2"	7/8"	215JM
10	3	L05331	8-1/2"	7/8"	215JM

NOTE 1: For an explanation of the tabulated material found on this page and for impeller key location, refer to *Supplement A* located at the beginning of this section.

NOTE 2: Also accepts gasket S05126 as replacement for o-ring. See *Supplement E* located at the beginning of this section.



Type "B" Single Stage Centrifugal Pump Electric Motor Drive

Section	CC
Page	350.5
Date	July 1, 2011
Supersedes 1/1/04	

BRONZE IMPELLER

B6ZPLS

Flanged Case

Mechanical Shaft Seal Construction

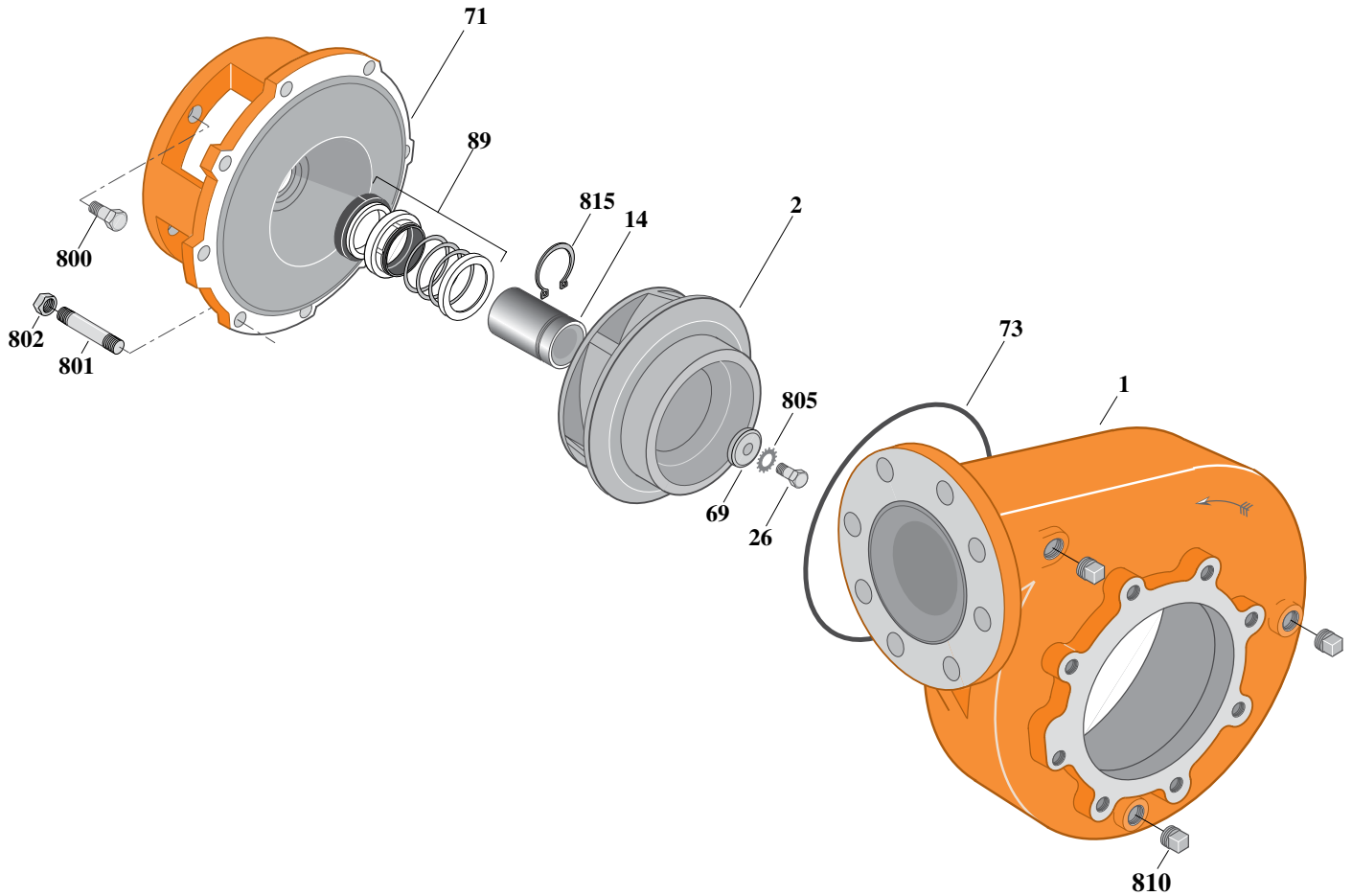

Item	Part Description	Part Number
1	Case, Volute	H05065
2	Impeller	See Table I
14	Sleeve, Shaft	S18869L
26	Screw, Impeller 1/2 - 13 x 3"	S23631
32	Key, 1/4 x 2-1/4" (See Note 1)	S23677
69	Washer, Impeller	S06319
71	Bracket	See Table II
73	O-Ring (See Note 2)	M14943
89	Seal, Mechanical Shaft	S32015
800	Capscrew, 1/2 - 13 x 1" (4 Req.)	S26912
801	Stud, 3/8 - 16 x 1-3/8" (8 Req.)	S09942
802	Nut, 3/8 -16 (8 Req.)	S23103
805	Washer, Lock	S23038
810	Plug, Pipe 1/2 NPT (3 Req.)	S23717
815	Ring, Retaining	S16767

Table I

B/M No.	HP	PH	RPM	"U" Dim.	Imp. Dia.	Imp. No.
B76779	15	3	1800	1-1/4"	7.56"x8.56"	M11568
B76780	20	3	1800	1-1/4"	8.00"x9.00"	M11567

Table II

HP	PH	Bracket No.	"AK" Fit	"U" Dim.	Motor Frame
15	3	L04615	8-1/2"	1-1/4"	254JM
20	3	L04615	8-1/2"	1-1/4"	256JM

NOTE 1: For an explanation of the tabulated material found on this page and for impeller key location, refer to *Supplement A* located at the beginning of this section.

NOTE 2: Also accepts gasket S05126 as replacement for o-ring. See *Supplement E* located at the beginning of this section.