



TYPE "B" SINGLE STAGE CENTRIFUGAL PUMP Electric Motor Drive

Section	CC
Page	380.1
Date	January 1, 2004
Supersedes 6/1/95	

CAST IRON IMPELLER

B6JPBM

Flanged Case

Packing Construction

TABLE I

B/M No.	HP	PH	RPM	"U" Dim.	Imp. Dia.	Imp. No.
B56757	10	3	1200	1-1/4"	10.94"	L06196
B58124	15	3	1200	1-1/4"	12.31"	L06199
B58125	20	3	1200	1-1/4"	13.50"	L05816

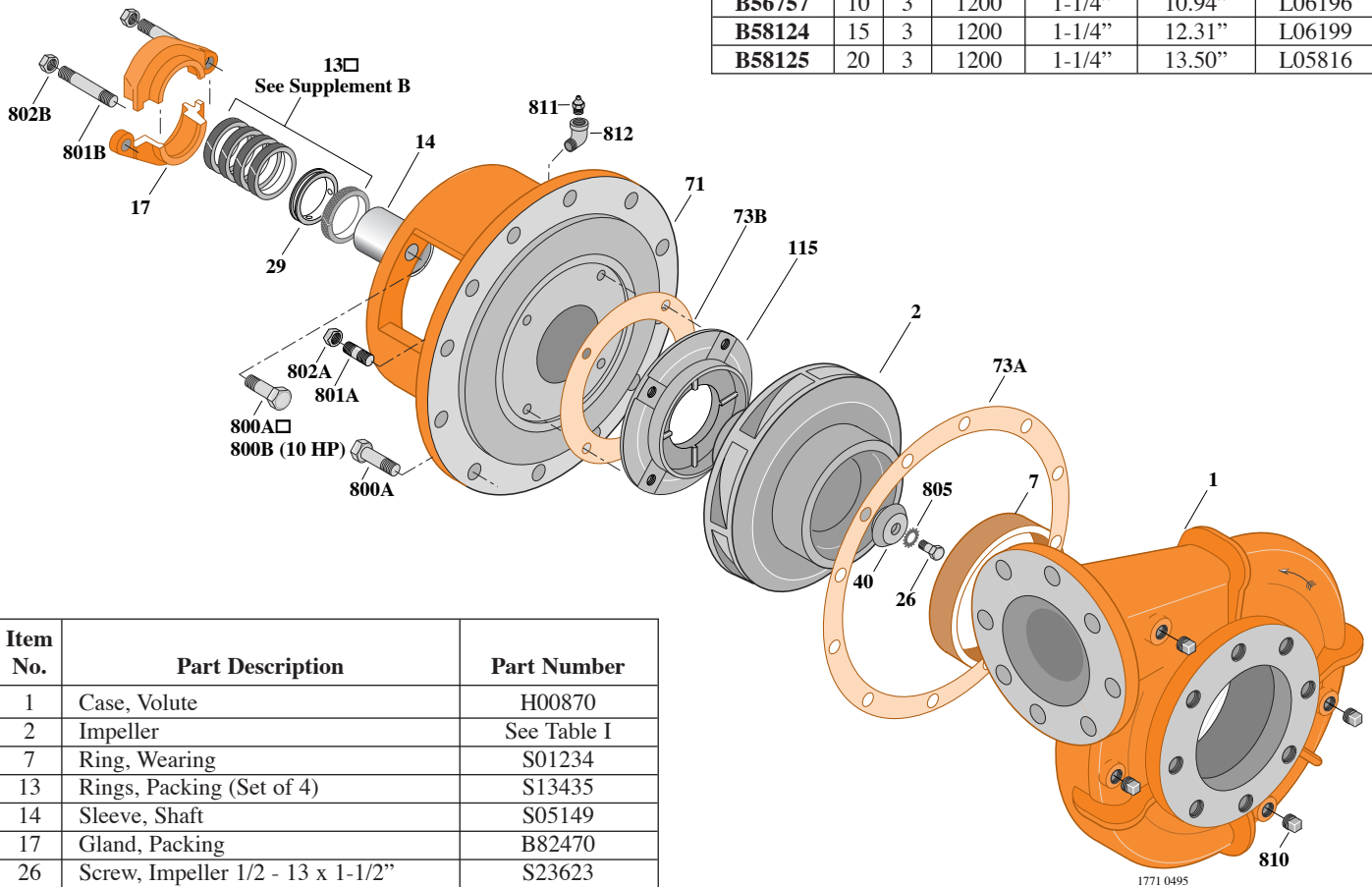

Item No.	Part Description	Part Number
1	Case, Volute	H00870
2	Impeller	See Table I
7	Ring, Wearing	S01234
13	Rings, Packing (Set of 4)	S13435
14	Sleeve, Shaft	S05149
17	Gland, Packing	B82470
26	Screw, Impeller 1/2 - 13 x 1-1/2"	S23623
29	Ring, Lantern	S19200
32	Key, 1/4 x 2-1/4" (See Note)	S23677
40	Deflector	S18117
71	Bracket	See Table II
73A	Gasket, Volute	S06271
73B	Gasket, Balance Ring	S09943
115	Ring, Balance	S12315
800A	Capscrew, 5/8 - 11 x 1-1/2" (12 Req.)	S26999
800B	Capscrew, 1/2 - 13 x 1-1/2" (4 Req.)	S26916
801A	Stud, 3/8 - 16 x 1-3/4" (4 Req.)	S23996
801B	Stud, 3/8 - 16 x 2-1/2" (2 Req.)	S04438
802A	Nut, Hex 3/8 - 16 (4 Req.)	S23103
802B	Nut, Hex 3/8 - 16 (2 Req.)	S23343
805	Washer, Lock	S23038
810	Plug, Pipe 1/2 NPT (4 Req.)	S23717
811	Fitting, Grease	S23700
812	Elbow, Street	S25421

TABLE II

HP	PH	Bracket No.	"AK" Fit	"U" Dim.	Motor Frame
10	3	H02384	8-1/2"	1-1/4"	256JP
15	3	H01601	12-1/2"	1-1/4"	284JP
20	3	H01601	12-1/2"	1-1/4"	286JP

NOTE: For an explanation of the tabulated material found on this page and for impeller key location, refer to *Supplement A* located at the beginning of this section.



TYPE "B" SINGLE STAGE CENTRIFUGAL PUMP Electric Motor Drive

Section	CC
Page	380.2
Date	January 1, 2004
Supersedes 6/1/95	

CAST IRON IMPELLER

B6JPBM

Flanged Case

Packing Construction

TABLE I

B/M No.	HP	PH	RPM	"U" Dim.	Imp. Dia.	Imp. No.
B58126	30	3	1800	1-1/4"	10.44"	L06200
B56761	40	3	1800	1-1/4"	11.44"	L06197
B56762	50	3	1800	1-1/4"	12.18"	L06198

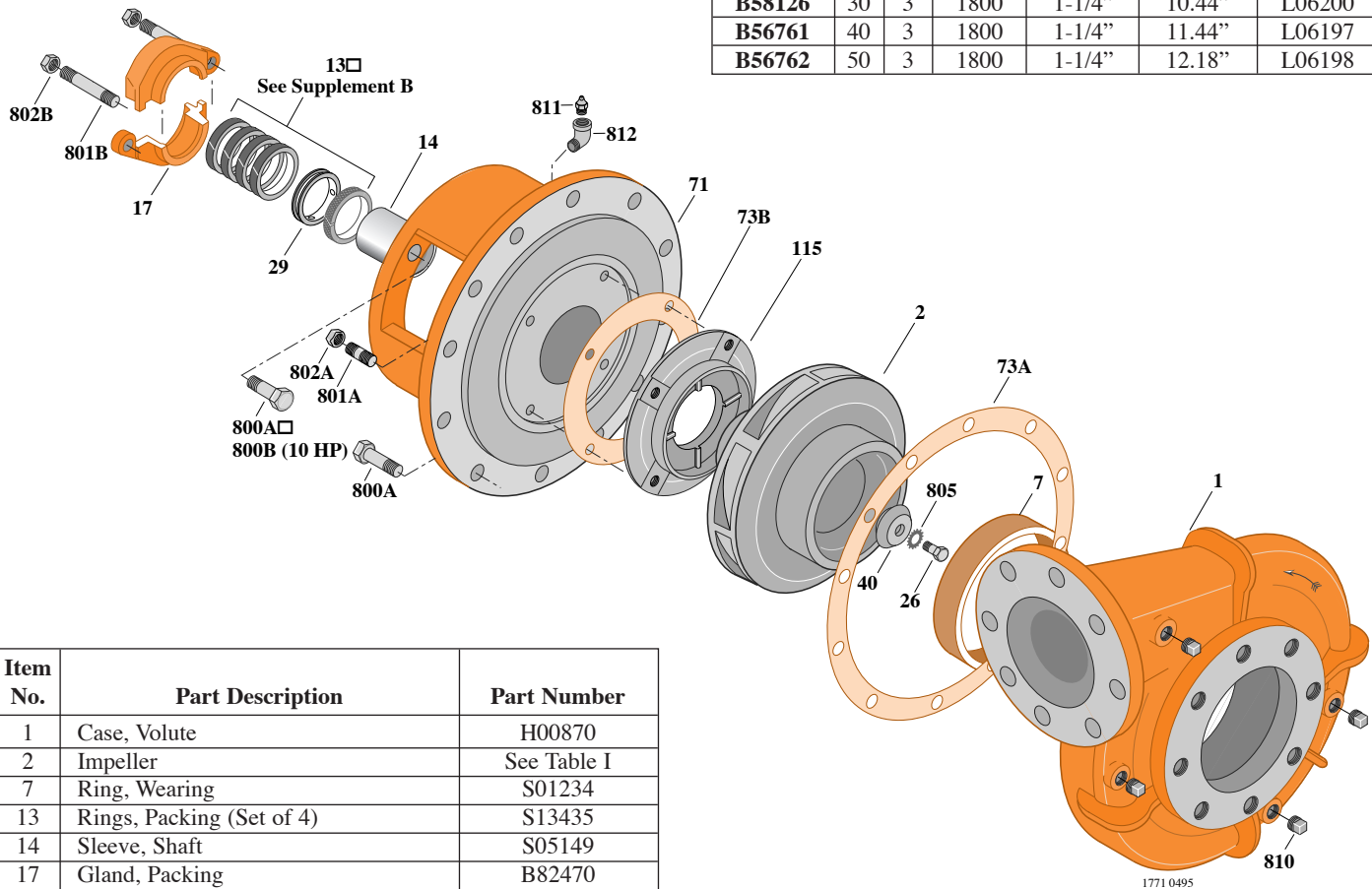

Item No.	Part Description	Part Number
1	Case, Volute	H00870
2	Impeller	See Table I
7	Ring, Wearing	S01234
13	Rings, Packing (Set of 4)	S13435
14	Sleeve, Shaft	S05149
17	Gland, Packing	B82470
26	Screw, Impeller 1/2 - 13 x 1-1/2"	S23623
29	Ring, Lantern	S19200
32	Key, 1/4 x 2-1/4" (See Note)	S23677
40	Deflector	S18117
71	Bracket	See Table II
73A	Gasket, Volute	S06271
73B	Gasket, Balance Ring	S09943
115	Ring, Balance	S12315
800	Capscrew, 5/8 - 11 x 1-1/2" (16 Req.)	S26999
801A	Stud, 3/8 - 16 x 1-3/4" (4 Req.)	S23996
801B	Stud, 3/8 - 16 x 2-1/2" (2 Req.)	S04438
802A	Nut, Hex 3/8 - 16 (4 Req.)	S23103
802B	Nut, Hex 3/8 - 16 (2 Req.)	S23343
805	Washer, Lock	S23038
811	Fitting, Grease	S23700
810	Plug, Pipe 1/2 NPT (4 Req.)	S23717
812	Elbow, Street	S25421

TABLE II

HP	PH	Bracket No.	"AK" Fit	"U" Dim.	Motor Frame
30	3	H01601	12-1/2"	1-1/4"	286JP
40	3	H01601	12-1/2"	1-1/4"	324JP
50	3	H01601	12-1/2"	1-1/4"	326JP

NOTE: For an explanation of the tabulated material found on this page and for impeller key location, refer to *Supplement A* located at the beginning of this section.



TYPE "B" SINGLE STAGE CENTRIFUGAL PUMP Electric Motor Drive

Section	CC
Page	380.3
Date	February 2, 2007
Supersedes 1/1/04	

CAST IRON IMPELLER

B6JPBM

Flanged Case

Packing Construction

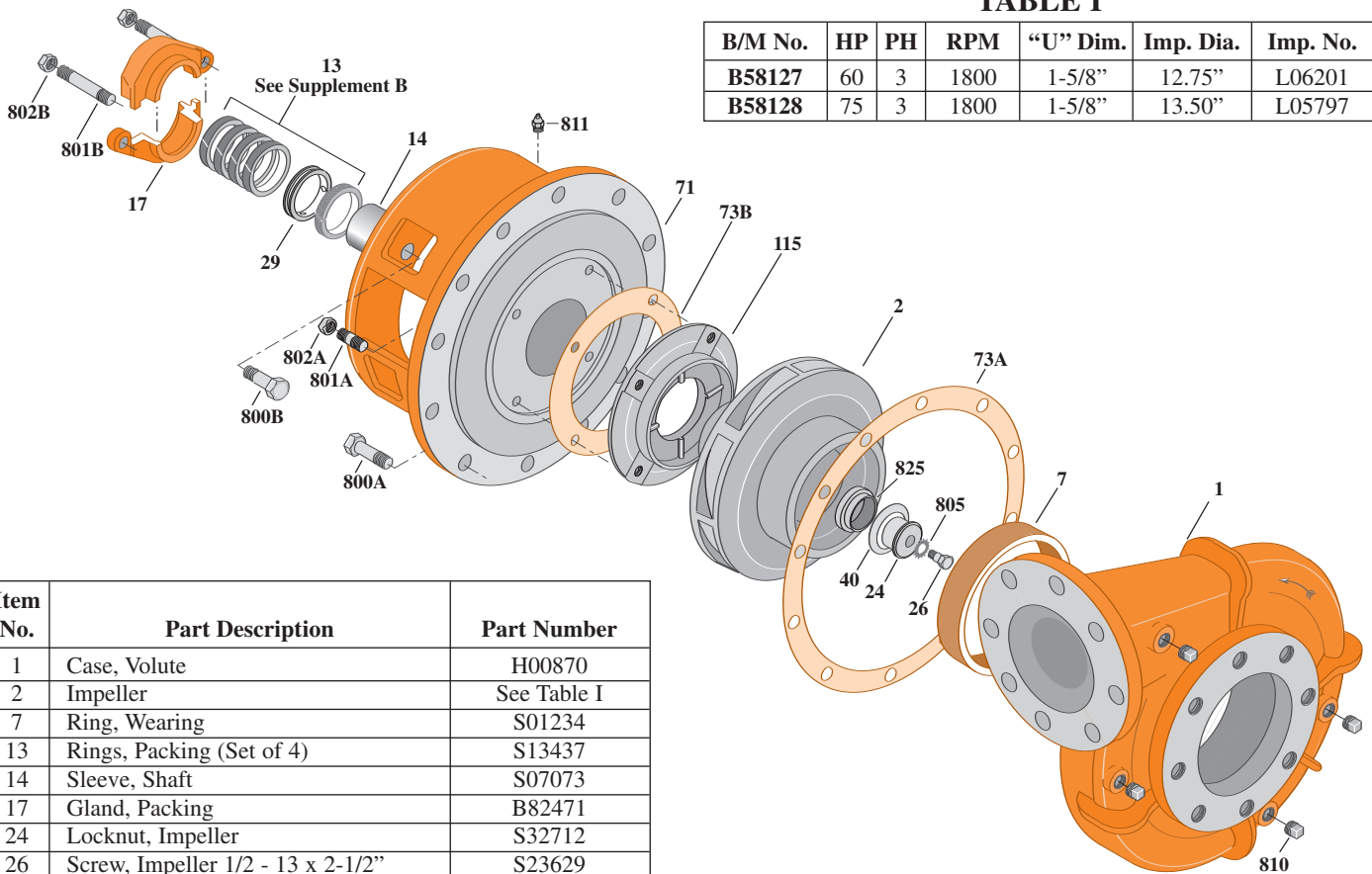

TABLE I

B/M No.	HP	PH	RPM	"U" Dim.	Imp. Dia.	Imp. No.
B58127	60	3	1800	1-5/8"	12.75"	L06201
B58128	75	3	1800	1-5/8"	13.50"	L05797

Item No.	Part Description	Part Number
1	Case, Volute	H00870
2	Impeller	See Table I
7	Ring, Wearing	S01234
13	Rings, Packing (Set of 4)	S13437
14	Sleeve, Shaft	S07073
17	Gland, Packing	B82471
24	Locknut, Impeller	S32712
26	Screw, Impeller 1/2 - 13 x 2-1/2"	S23629
29	Ring, Lantern	S19198
32	Key, 3/8 x 2-1/4" (See Note)	S23940
40	Deflector	S19864
71	Bracket	See Table II
73A	Gasket, Volute	S06271
73B	Gasket, Balance Ring	S09943
115	Ring, Balance	S12334
800A	Capscrew, 5/8 - 11 x 1-1/2" (12 Req.)	S26999
800B	Capscrew, 5/8 - 11 x 1-3/4" (4 Req.)	S27001
801A	Stud, 3/8 - 16 x 1-3/4" (4 Req.)	S23996
801B	Stud, 3/8 - 16 x 2-1/2" (2 Req.)	S04438
802A	Nut, Hex 3/8 - 16 (4 Req.)	S23103
802B	Nut, Hex 3/8 - 16 (2 Req.)	S23343
805	Washer, Lock	S23038
810A	Plug, Pipe 1/2 NPT (4 Req.)	S23717
810B	Plug, Pipe 1/4 NPT (2 Req.) (Not Illustrated)	S23715
811	Fitting, Grease	S23700
812	Elbow, Street	S25421
825	Sleeve, Impeller Locknut	S31661

TABLE II

HP	PH	Bracket No.	"AK" Fit	"U" Dim.	Motor Frame
60	3	H03622	12-1/2"	1-5/8"	364JP
75	3	H03622	12-1/2"	1-5/8"	365JP

NOTE: For an explanation of the tabulated material found on this page and for impeller key location, refer to *Supplement A* located at the beginning of this section.

1772 0495



TYPE "B" SINGLE STAGE CENTRIFUGAL PUMP Electric Motor Drive

Section	CC
Page	380.4
Date	January 1, 2004
Supersedes 6/1/95	

CAST IRON IMPELLER

B6JPBMS

Flanged Case

Mechanical Shaft Seal Construction

TABLE I

B/M No.	HP	PH	RPM	"U" Dim.	Imp. Dia.	Imp. No.
B56765	10	3	1200	1-1/4"	10.94"	L06196
B56766	15	3	1200	1-1/4"	12.31"	L06199
B56767	20	3	1200	1-1/4"	13.50"	L05816

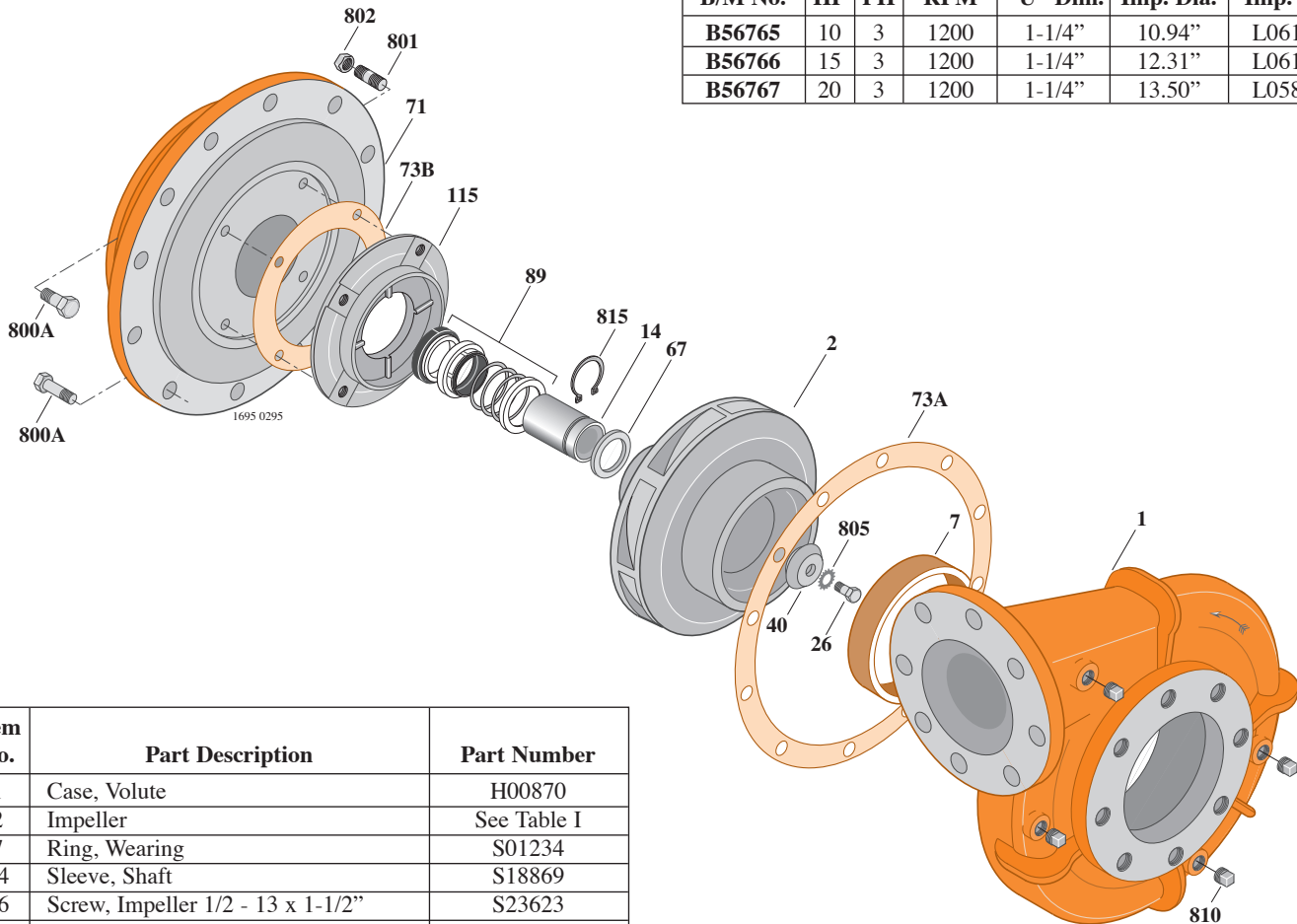

Item No.	Part Description	Part Number
1	Case, Volute	H00870
2	Impeller	See Table I
7	Ring, Wearing	S01234
14	Sleeve, Shaft	S18869
26	Screw, Impeller 1/2 - 13 x 1-1/2"	S23623
32	Key, 1/4 x 2-1/4" (See Note)	S23677
40	Deflector	S18117
67	Ring, Spacer	S19349
71	Bracket	See Table II
73A	Gasket, Volute Case	S06271
73B	Gasket, Balance Ring	S09943
89	Seal, Mechanical Shaft	S32015
115	Ring, Balance	S19105
800A	Capscrew, 5/8 - 11 x 1-1/2" (12 Req.-8-1/2 AK; 16 Req.-12-1/2 AK)	S26999
800B	Capscrew, 1/2 - 13 x 1-1/2" (4 Req.) (8-1/2 AK Only)	S26916
801	Stud, 3/8 - 16 x 1-1/2" (4 Req.)	S23995
802	Nut, 3/8 - 16 (4 Req.)	S23103
805	Washer, Lock	S23038
810	Plug, Pipe 1/2 NPT (4 Req.)	S23717
815	Ring, Retaining	S16767

TABLE II

HP	PH	Bracket No.	"AK" Fit	"U" Dim.	Motor Frame
10	3	H03300	8-1/2"	1-1/4"	256JM
15	3	H03301	12-1/2"	1-1/4"	284JM
20	3	H03301	12-1/2"	1-1/4"	286JM

NOTE: For an explanation of the tabulated material found on this page and for impeller key location, refer to *Supplement A* located at the beginning of this section.



TYPE "B" SINGLE STAGE CENTRIFUGAL PUMP Electric Motor Drive

Section	CC
Page	380.5
Date	January 1, 2004
Supersedes 6/1/95	

CAST IRON IMPELLER

B6JPBMS

Flanged Case

Mechanical Shaft Seal Construction

TABLE I

B/M No.	HP	PH	RPM	"U" Dim.	Imp. Dia.	Imp. No.
B56768	30	3	1800	1-1/4"	10.44"	L06200
B56769	40	3	1800	1-1/4"	11.44"	L06197
B56770	50	3	1800	1-1/4"	12.18"	L06198

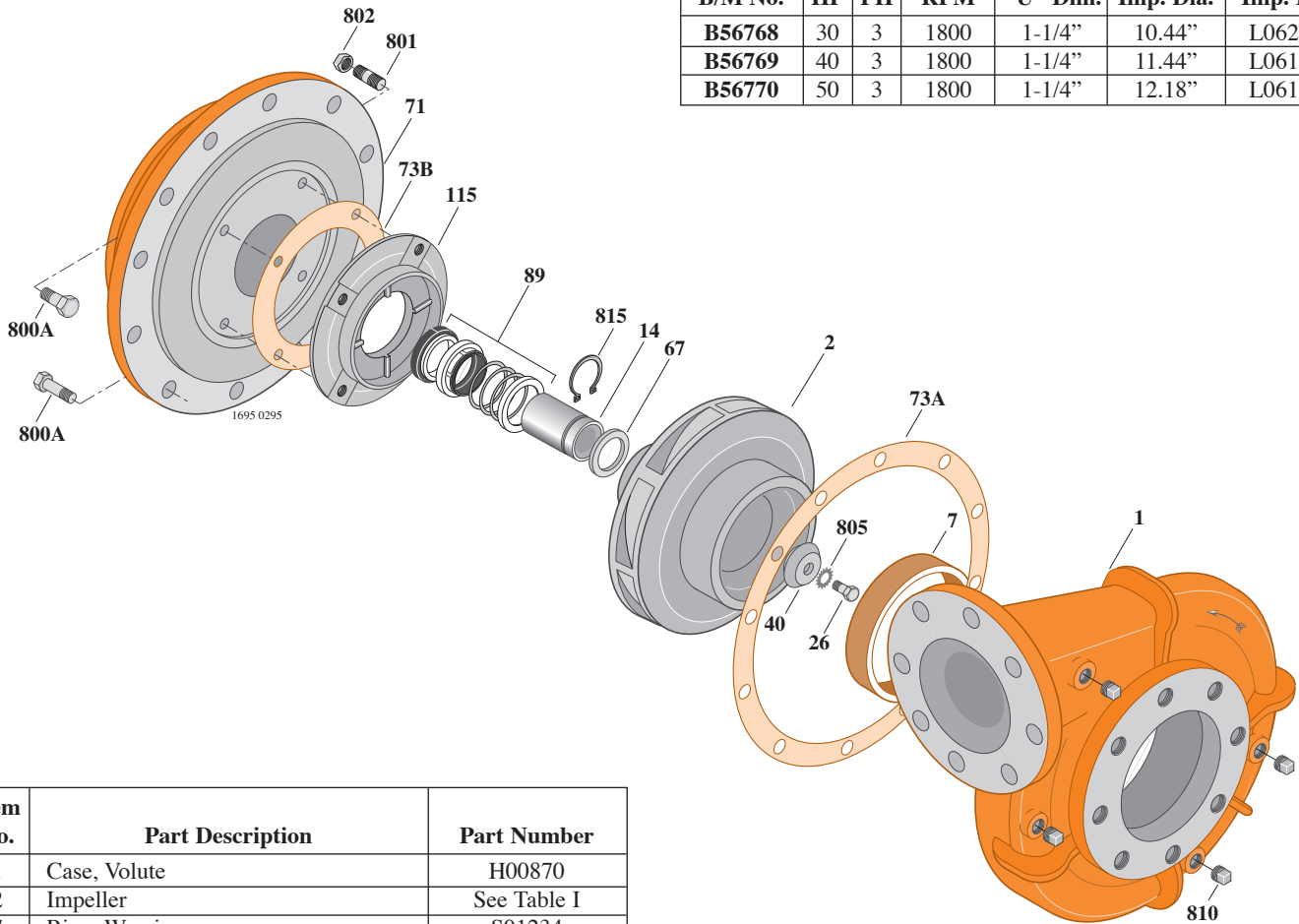

Item No.	Part Description	Part Number
1	Case, Volute	H00870
2	Impeller	See Table I
7	Ring, Wearing	S01234
14	Sleeve, Shaft	S18869
26	Screw, Impeller 1/2 - 13 x 1-1/2"	S23623
32	Key, 1/4 x 2-1/4" (See Note)	S23677
40	Deflector	S18117
67	Ring, Spacer	S19349
71	Bracket	See Table II
73A	Gasket, Volute Case	S06271
73B	Gasket, Balance Ring	S09943
89	Seal, Mechanical Shaft	S32015
115	Ring, Balance	S19105
800A	Capscrew, 5/8 - 11 x 1-1/2" (16 Req.)	S26999
801	Stud, 3/8 - 16 x 1-1/2" (4 Req.)	S23995
802	Nut, 3/8 - 16 (4 Req.)	S23103
805	Washer, Lock	S23038
810	Plug, Pipe 1/2 NPT (4 Req.)	S23717
815	Ring, Retaining	S16767

TABLE II

HP	PH	Bracket No.	"AK" Fit	"U" Dim.	Motor Frame
30	3	H03301	12-1/2"	1-1/4"	286JM
40	3	H03301	12-1/2"	1-1/4"	324JM
50	3	H03301	12-1/2"	1-1/4"	326JM

NOTE: For an explanation of the tabulated material found on this page and for impeller key location, refer to *Supplement A* located at the beginning of this section.



TYPE "B" SINGLE STAGE CENTRIFUGAL PUMP Electric Motor Drive

Section	CC
Page	380.6
Date	February 2, 2007
Supersedes 1/1/04	

CAST IRON IMPELLER B6JPBMS

Flanged Case

Mechanical Shaft Seal Construction

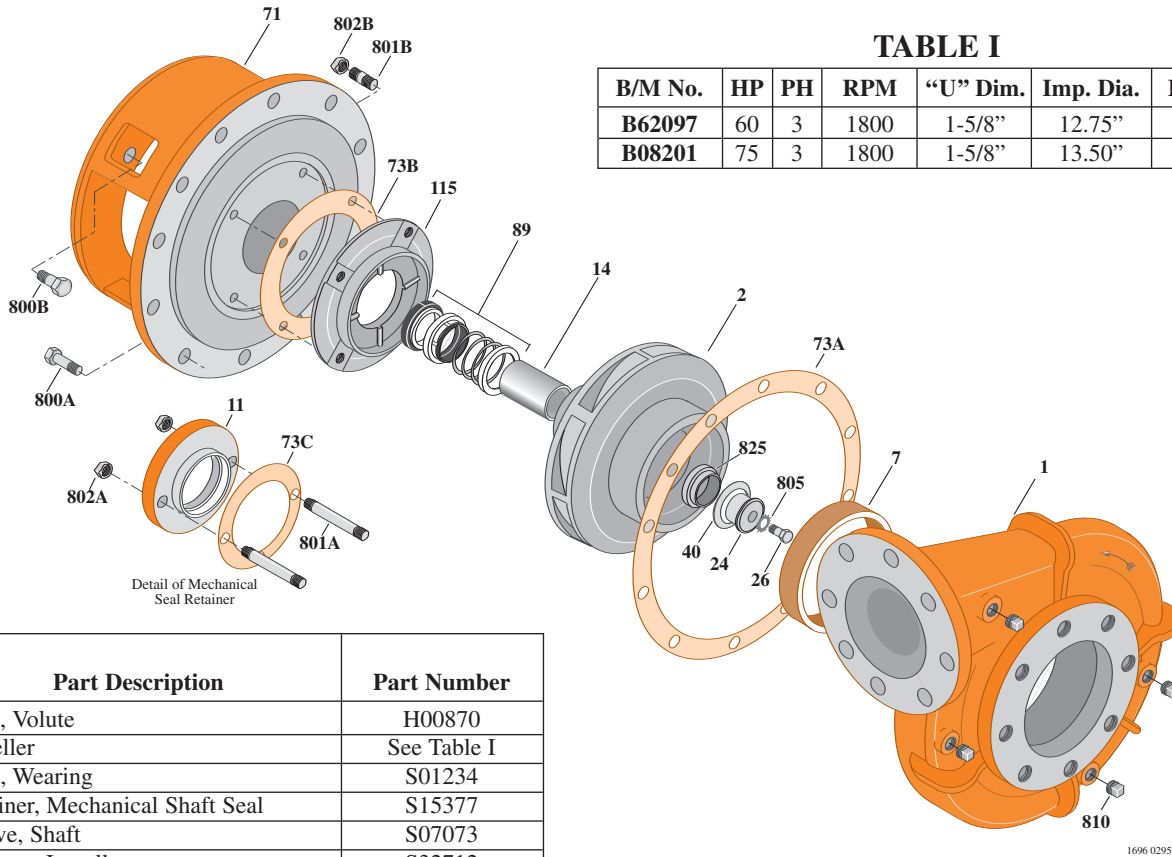

TABLE I

B/M No.	HP	PH	RPM	"U" Dim.	Imp. Dia.	Imp. No.
B62097	60	3	1800	1-5/8"	12.75"	L06201
B08201	75	3	1800	1-5/8"	13.50"	L05797

Item No.	Part Description	Part Number
1	Case, Volute	H00870
2	Impeller	See Table I
7	Ring, Wearing	S01234
11	Retainer, Mechanical Shaft Seal	S15377
14	Sleeve, Shaft	S07073
24	Locknut, Impeller	S32712
26	Screw, Impeller 1/2 - 13 x 2-1/2"	S23629
32	Key, 3/8 x 2-1/4" (See Note)	S23940
40	Deflector	S19864
71	Bracket	See Table II
73A	Gasket, Volute Case	S06271
73B	Gasket, Balance Ring	S09943
73C	Gasket, Seal Retainer	S15078
89	Seal, Mechanical Shaft	S32016
115	Ring, Balance	S12334
800A	Capscrew, 5/8 - 11 x 1-1/2" (12 Req.)	S26999
800B	Capscrew, 5/8 - 11 x 1-3/4" (4 Req.)	S27001
801A	Stud, 3/8 - 16 x 2-1/2" (2 Req.)	S04438
802A	Nut, 3/8 - 16 (2 Req.)	S23343
801B	Stud, 3/8 - 16 x 1-3/4" (4 Req.)	S23996
802B	Nut, 3/8 - 16 (4 Req.)	S23103
805	Washer, Lock	S23038
810	Plug, Pipe 1/2 NPT (4 Req.)	S23717
820	Connector, Comp. Fitting (2 Req.)	S24013
822	Tubing, Copper	S20677
825	Sleeve, Impeller Locknut	S31661
•	Plug, Pipe 1/8 NPT (Not Illustrated)	S23714
•	Plug, Pipe 1/4 NPT (Not Illustrated)	S23715

TABLE II

HP	PH	Bracket No.	"AK" Fit	"U" Dim.	Motor Frame
60	3	H03936	12-1/2"	1-5/8"	364JP
75	3	H03936	12-1/2"	1-5/8"	365JP

NOTE: For an explanation of the tabulated material found on this page and for impeller key location, refer to *Supplement A* located at the beginning of this section.



TYPE "B" SINGLE STAGE CENTRIFUGAL PUMP Electric Motor Drive

Section	CC
Page	380.7
Date	February 2, 2007
Supersedes 1/1/04	

SILICON BRONZE IMPELLER

B6JPBM

Flanged Case

Packing Construction

TABLE I

B/M No.	HP	PH	RPM	"U" Dim.	Imp. Dia.	Imp. No.
B74921	60	3	1800	1-5/8"	12.75"	H05690
B74925	75	3	1800	1-5/8"	13.50"	H05691

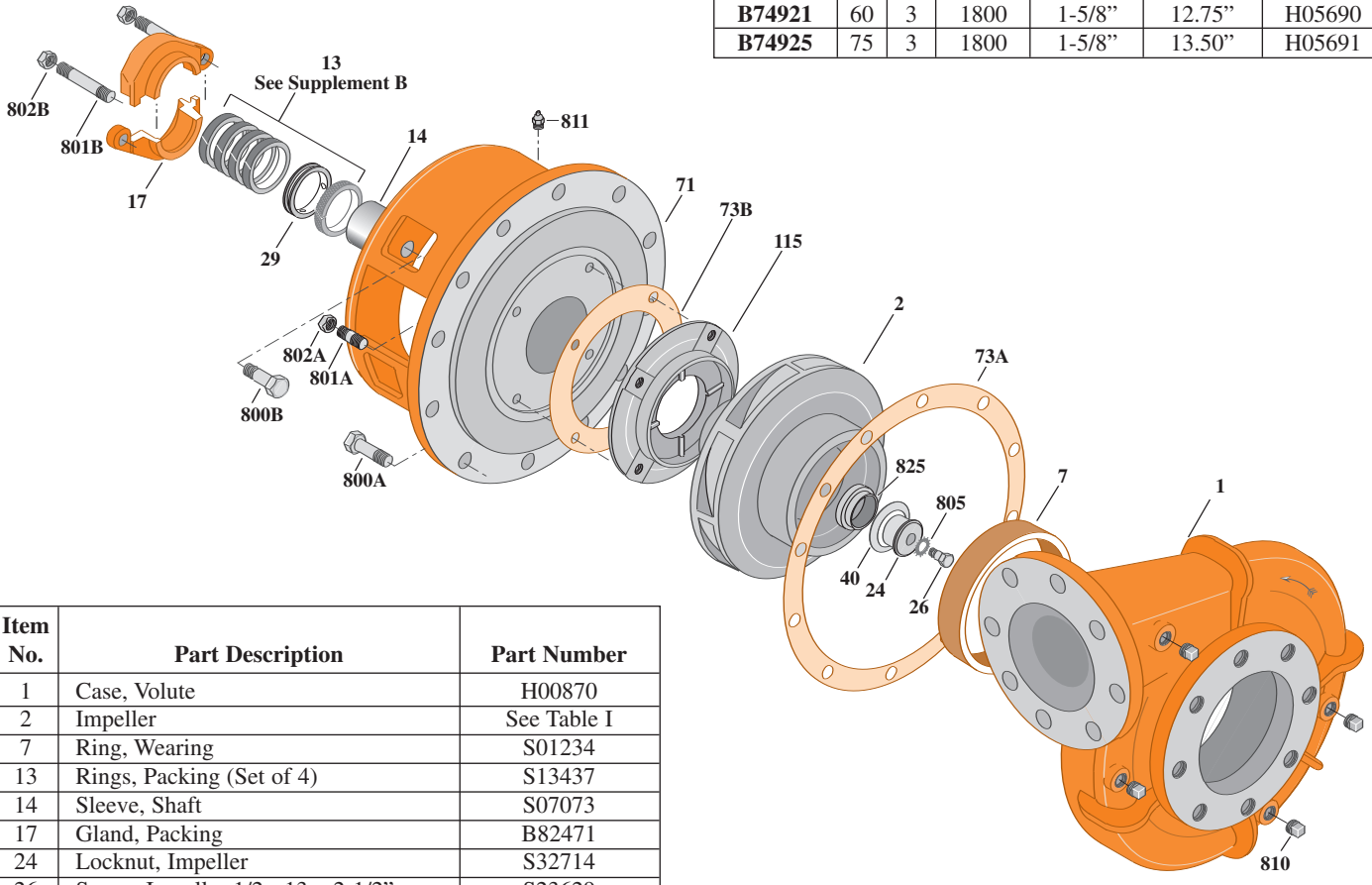

1772 0495

Item No.	Part Description	Part Number
1	Case, Volute	H00870
2	Impeller	See Table I
7	Ring, Wearing	S01234
13	Rings, Packing (Set of 4)	S13437
14	Sleeve, Shaft	S07073
17	Gland, Packing	B82471
24	Locknut, Impeller	S32714
26	Screw, Impeller 1/2 - 13 x 2-1/2"	S23629
29	Ring, Lantern	S19198
32	Key, 3/8 x 2-1/4" (See Note)	S23940
40	Deflector	S19864
71	Bracket	See Table II
73A	Gasket, Volute	S06271
73B	Gasket, Balance Ring	S09943
115	Ring, Balance	S12334
800A	Capscrew, 5/8 - 11 x 1-1/2" (12 Req.)	S26999
800B	Capscrew, 5/8 - 11 x 1-3/4" (4 Req.)	S27001
801A	Stud, 3/8 - 16 x 1-3/4" (4 Req.)	S23996
801B	Stud, 3/8 - 16 x 2-1/2" (2 Req.)	S04438
802A	Nut, Hex 3/8 - 16 (4 Req.)	S23103
802B	Nut, Hex 3/8 - 16 (2 Req.)	S23343
805	Washer, Lock	S23038
810	Plug, Pipe 1/2" NPT (4 Req.)	S23717
811	Fitting, Grease	S23700
825	Sleeve, Impeller Locknut	S31661

TABLE II

HP	PH	Bracket No.	"AK" Fit	"U" Dim.	Motor Frame
60	3	H03622	12-1/2"	1-5/8"	364JP
75	3	H03622	12-1/2"	1-5/8"	365JP

NOTE: For an explanation of the tabulated material found on this page and for impeller key location, refer to *Supplement A* located at the beginning of this section.



TYPE "B" SINGLE STAGE CENTRIFUGAL PUMP Electric Motor Drive

Section	CC
Page	380.8
Date	January 1, 2004
Supersedes 9/1/97	

SILICON BRONZE IMPELLER

B6JPBMS

Flanged Case

Mechanical Shaft Seal Construction

TABLE I

B/M No.	HP	PH	RPM	"U" Dim.	Imp. Dia.	Imp. No.
B74929	10	3	1200	1-1/4"	10.94"	H05684
B74933	15	3	1200	1-1/4"	12.31"	H05687
B74937	20	3	1200	1-1/4"	13.50"	H05689

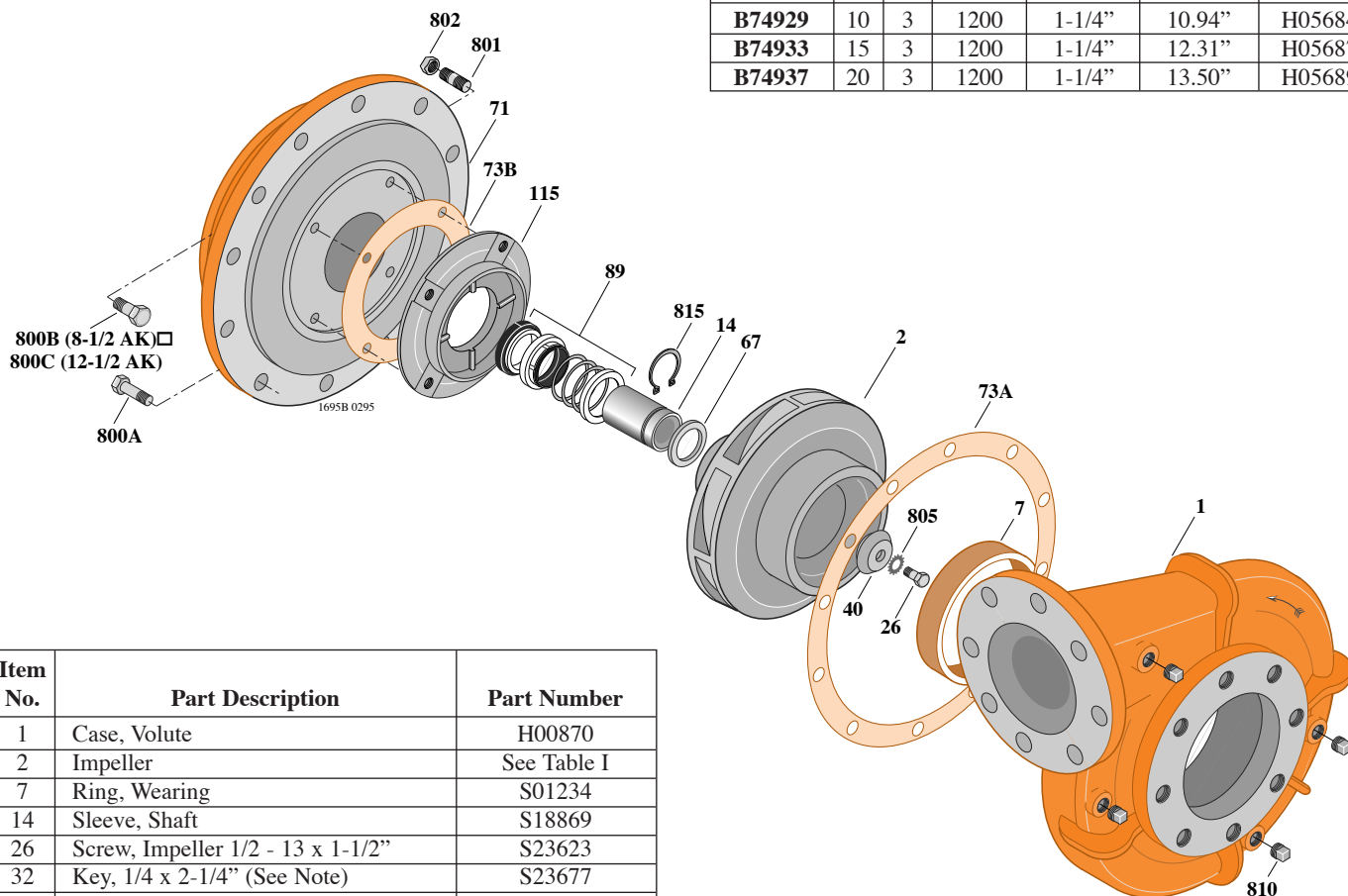

Item No.	Part Description	Part Number
1	Case, Volute	H00870
2	Impeller	See Table I
7	Ring, Wearing	S01234
14	Sleeve, Shaft	S18869
26	Screw, Impeller 1/2 - 13 x 1-1/2"	S23623
32	Key, 1/4 x 2-1/4" (See Note)	S23677
40	Deflector	S18117
67	Ring, Spacer	S19349
71	Bracket	See Table II
73A	Gasket, Volute Case	S06271
73B	Gasket, Balance Ring	S09943
89	Seal, Mechanical Shaft	S32015
115	Ring, Balance	S19105
800A	Capscrew, 5/8 - 11 x 1-1/2" (12 Req.)	S26999
800B	Capscrew, 1/2 - 13 x 1-1/2" (4 Req.)	S26916
800C	Capscrew, 5/8 - 11 x 1-1/2" (4 Req.)	S26999
801	Stud, 3/8 - 16 x 1-1/2" (4 Req.)	S23995
802	Nut, 3/8 - 16 (4 Req.)	S23103
805	Washer, Lock	S23038
810	Plug, Pipe 1/2" NPT (4 Req.)	S23717
815	Ring, Retaining	S16767
•	Plug, Pipe 1/8" NPT (In Bracket)	S23714

• Not illustrated.

TABLE II

HP	PH	Bracket No.	"AK" Fit	"U" Dim.	Motor Frame
10	3	H03300	8-1/2"	1-1/4"	256JM
15	3	H03301	12-1/2"	1-1/4"	284JM
20	3	H03301	12-1/2"	1-1/4"	286JM

NOTE: For an explanation of the tabulated material found on this page and for impeller key location, refer to *Supplement A* located at the beginning of this section.

NOTE: For seal flush line details, see *Supplement D*.



TYPE "B" SINGLE STAGE CENTRIFUGAL PUMP Electric Motor Drive

Section	CC
Page	380.9
Date	January 1, 2004
Supersedes 9/1/97	

SILICON BRONZE IMPELLER

B6JPBM

Flanged Case

Packing Construction

TABLE I

B/M No.	HP	PH	RPM	"U" Dim.	Imp. Dia.	Imp. No.
B74897	10	3	1200	1-1/4"	10.94"	H05684
B74901	15	3	1200	1-1/4"	12.31"	H05687
B74905	20	3	1200	1-1/4"	13.50"	H05689

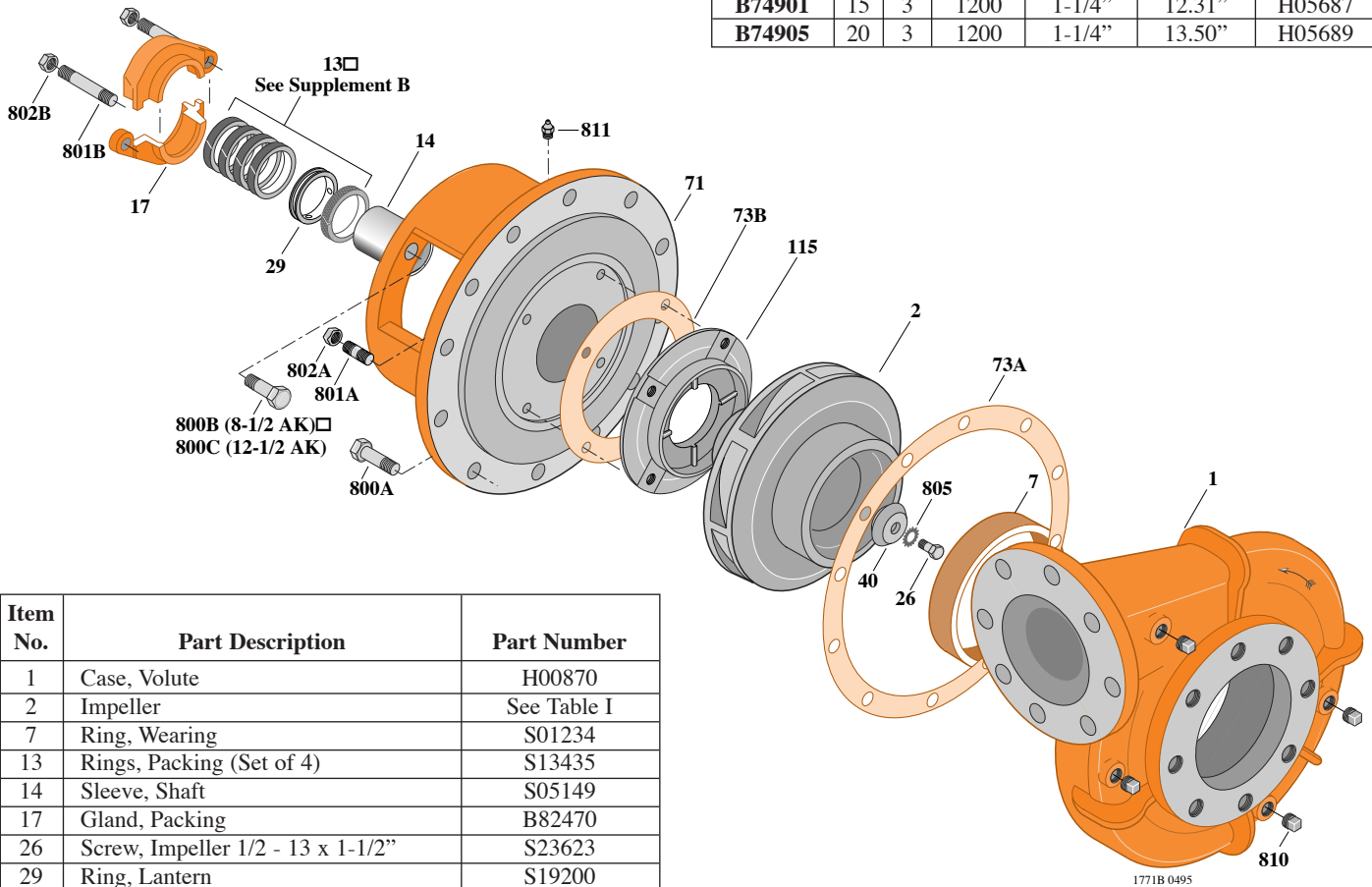

Item No.	Part Description	Part Number
1	Case, Volute	H00870
2	Impeller	See Table I
7	Ring, Wearing	S01234
13	Rings, Packing (Set of 4)	S13435
14	Sleeve, Shaft	S05149
17	Gland, Packing	B82470
26	Screw, Impeller 1/2 - 13 x 1-1/2"	S23623
29	Ring, Lantern	S19200
32	Key, 1/4 x 2-1/4" (See Note)	S23677
40	Deflector	S18117
71	Bracket	See Table II
73A	Gasket, Volute	S06271
73B	Gasket, Balance Ring	S09943
115	Ring, Balance	S12315
800A	Capscrew, 5/8 - 11 x 1-1/2" (12 Req.)	S26999
800B	Capscrew, 1/2 - 13 x 1-1/2" (4 Req.)	S26916
800C	Capscrew, 5/8 - 11 x 1-1/2" (4 Req.)	S26999
801A	Stud, 3/8 - 16 x 1-3/4" (4 Req.)	S23996
801B	Stud, 3/8 - 16 x 2-1/2" (2 Req.)	S04438
802A	Nut, Hex 3/8 - 16 (4 Req.)	S23103
802B	Nut, Hex 3/8 - 16 (2 Req.)	S23343
805	Washer, Lock	S23038
810	Plug, Pipe 1/2" NPT (4 Req.)	S23717
811	Fitting, Grease	S23700

TABLE II

HP	PH	Bracket No.	"AK" Fit	"U" Dim.	Motor Frame
10	3	H02384	8-1/2"	1-1/4"	256JP
15	3	H01601	12-1/2"	1-1/4"	284JP
20	3	H01601	12-1/2"	1-1/4"	286JP

NOTE: For an explanation of the tabulated material found on this page and for impeller key location, refer to *Supplement A* located at the beginning of this section.



TYPE "B" SINGLE STAGE CENTRIFUGAL PUMP Electric Motor Drive

Section	CC
Page	380.10
Date	January 1, 2004
Supersedes 9/1/97	

SILICON BRONZE IMPELLER

B6JPBM

Flanged Case

Packing Construction

TABLE I

B/M No.	HP	PH	RPM	"U" Dim.	Imp. Dia.	Imp. No.
B74909	30	3	1800	1-1/4"	10.44"	H05682
B74913	40	3	1800	1-1/4"	11.44"	H05685
B74917	50	3	1800	1-1/4"	12.18"	H05686

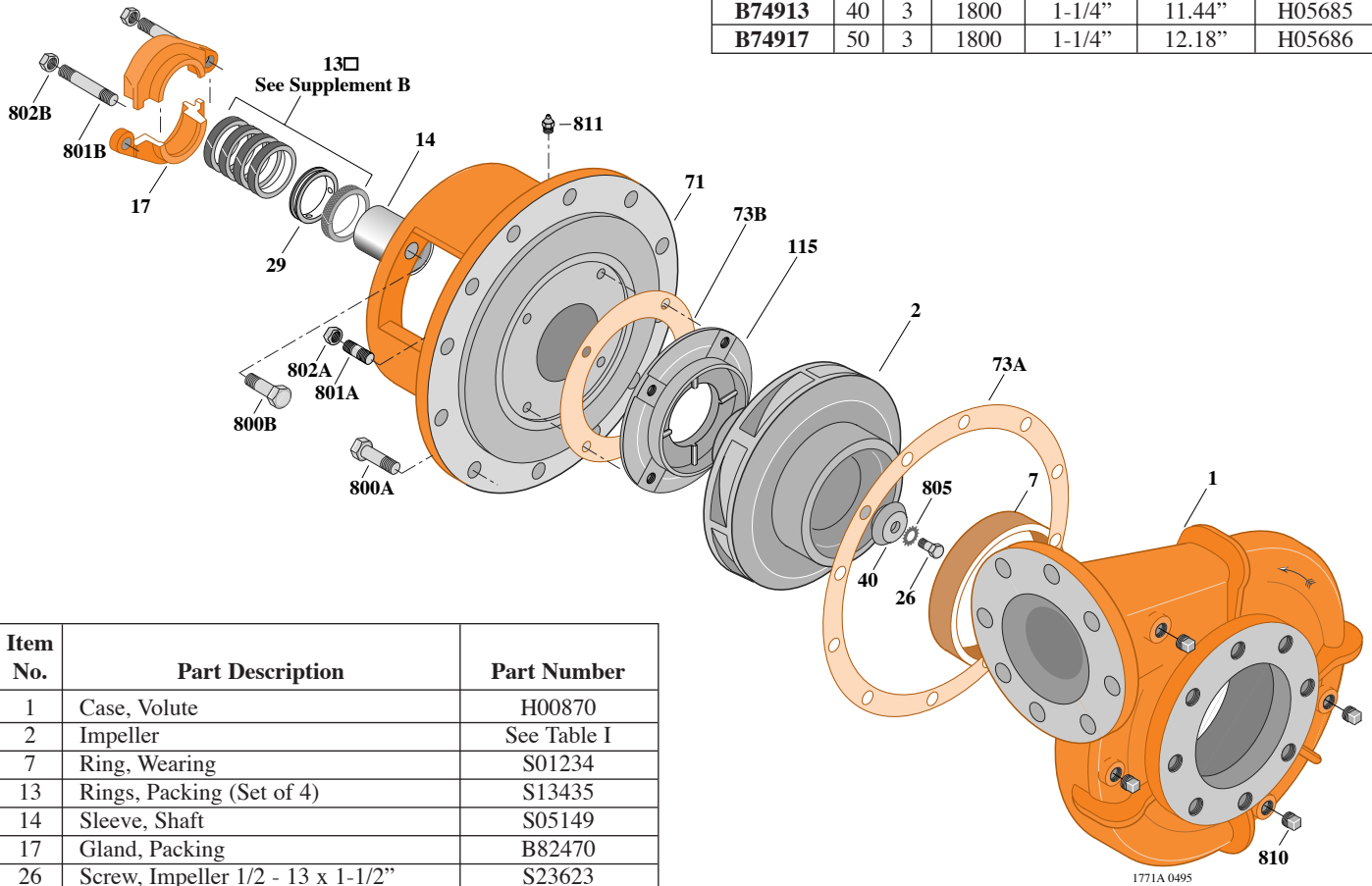

Item No.	Part Description	Part Number
1	Case, Volute	H00870
2	Impeller	See Table I
7	Ring, Wearing	S01234
13	Rings, Packing (Set of 4)	S13435
14	Sleeve, Shaft	S05149
17	Gland, Packing	B82470
26	Screw, Impeller 1/2 - 13 x 1-1/2"	S23623
29	Ring, Lantern	S19200
32	Key, 1/4 x 2-1/4" (See Note)	S23677
40	Deflector	S18117
71	Bracket	See Table II
73A	Gasket, Volute	S06271
73B	Gasket, Balance Ring	S09943
115	Ring, Balance	S12315
800A	Capscrew, 5/8 - 11 x 1-1/2" (12 Req.)	S26999
800B	Capscrew, 5/8 - 11 x 1-1/2" (4 Req.)	S26999
801A	Stud, 3/8 - 16 x 1-3/4" (4 Req.)	S23996
801B	Stud, 3/8 - 16 x 2-1/2" (2 Req.)	S04438
802A	Nut, Hex 3/8 - 16 (4 Req.)	S23103
802B	Nut, Hex 3/8 - 16 (2 Req.)	S23343
805	Washer, Lock	S23038
810	Plug, Pipe 1/2" NPT (4 Req.)	S23717
811	Fitting, Grease	S23700

TABLE II

HP	PH	Bracket No.	"AK" Fit	"U" Dim.	Motor Frame
30	3	H01601	12-1/2"	1-1/4"	286JP
40	3	H01601	12-1/2"	1-1/4"	324JP
50	3	H01601	12-1/2"	1-1/4"	326JP

NOTE: For an explanation of the tabulated material found on this page and for impeller key location, refer to *Supplement A* located at the beginning of this section.



TYPE "B" SINGLE STAGE CENTRIFUGAL PUMP Electric Motor Drive

Section	CC
Page	380.11
Date	January 1, 2004
Supersedes 9/1/97	

SILICON BRONZE IMPELLER

B6JPBMS

Flanged Case

Mechanical Shaft Seal Construction

TABLE I

B/M No.	HP	PH	RPM	"U" Dim.	Imp. Dia.	Imp. No.
B74941	30	3	1800	1-1/4"	10.44"	H05687
B74945	40	3	1800	1-1/4"	11.44"	H05685
B74949	50	3	1800	1-1/4"	12.18"	H05686

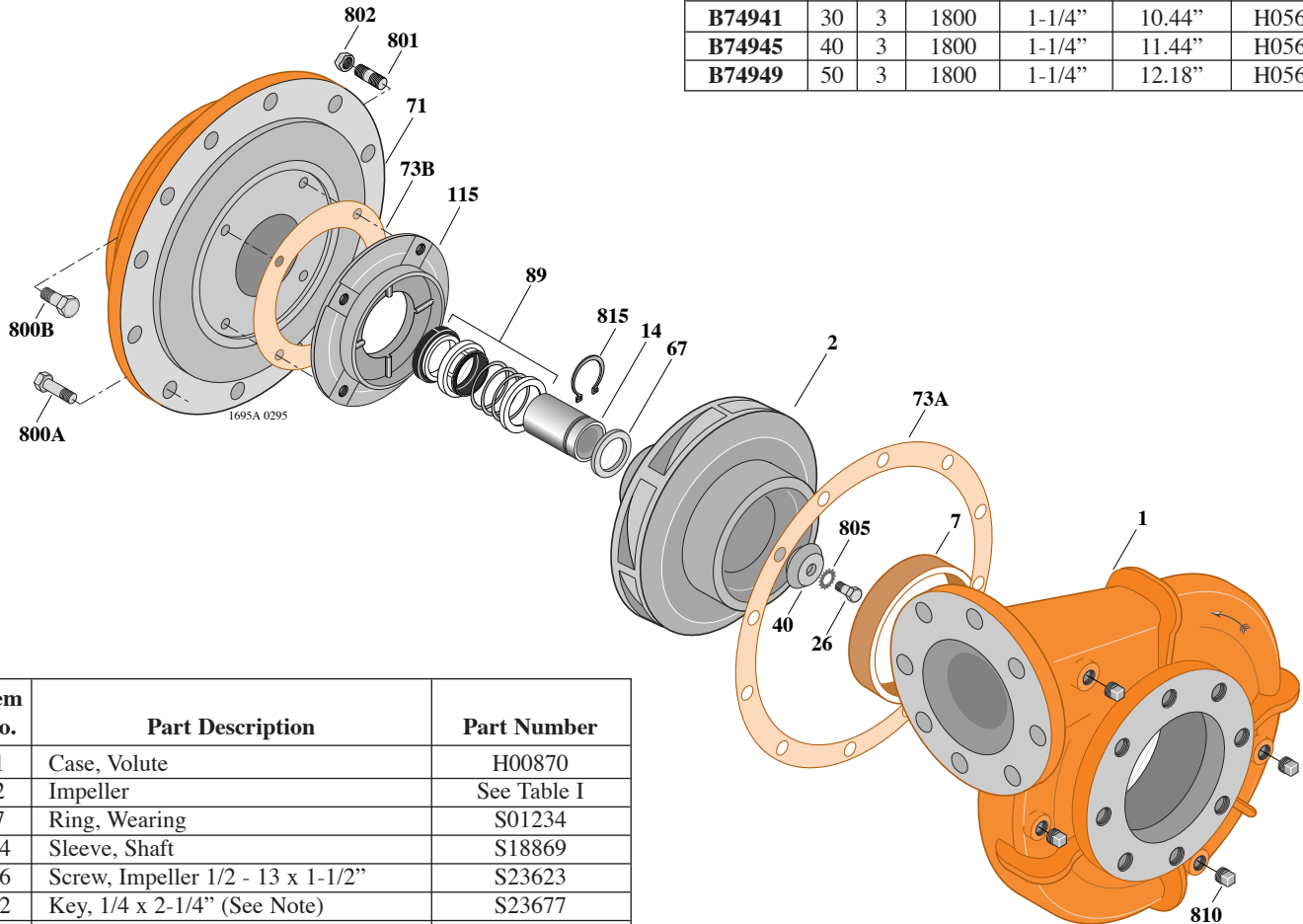

Item No.	Part Description	Part Number
1	Case, Volute	H00870
2	Impeller	See Table I
7	Ring, Wearing	S01234
14	Sleeve, Shaft	S18869
26	Screw, Impeller 1/2 - 13 x 1-1/2"	S23623
32	Key, 1/4 x 2-1/4" (See Note)	S23677
40	Deflector	S18117
67	Ring, Spacer	S19349
71	Bracket	See Table II
73A	Gasket, Volute Case	S06271
73B	Gasket, Balance Ring	S09943
89	Seal, Mechanical Shaft	S32015
115	Ring, Balance	S19105
800A	Capscrew, 5/8 - 11 x 1-1/2" (12 Req.)	S26999
800B	Capscrew, 5/8 - 11 x 1-1/2" (4 Req.)	S26999
801	Stud, 3/8 - 16 x 1-1/2" (4 Req.)	S23995
802	Nut, 3/8 - 16 (4 Req.)	S23103
805	Washer, Lock	S23038
810	Plug, Pipe 1/2" NPT (4 Req.)	S23717
815	Ring, Retaining	S16767
•	Plug, Pipe 1/8" NPT (In Bracket)	S23714

• Not illustrated.

TABLE II

HP	PH	Bracket No.	"AK" Fit	"U" Dim.	Motor Frame
30	3	H03301	12-1/2"	1-1/4"	286JM
40	3	H03301	12-1/2"	1-1/4"	324JM
50	3	H03301	12-1/2"	1-1/4"	326JM

NOTE: For an explanation of the tabulated material found on this page and for impeller key location, refer to *Supplement A* located at the beginning of this section.

NOTE: For seal flush line details, see *Supplement D*.



TYPE "B" SINGLE STAGE CENTRIFUGAL PUMP Electric Motor Drive

Section	CC
Page	380.12
Date	February 2, 2007
Supersedes 1/1/04	

SILICON BRONZE IMPELLER

B6JPBMS

Flanged Case

Mechanical Shaft Seal Construction

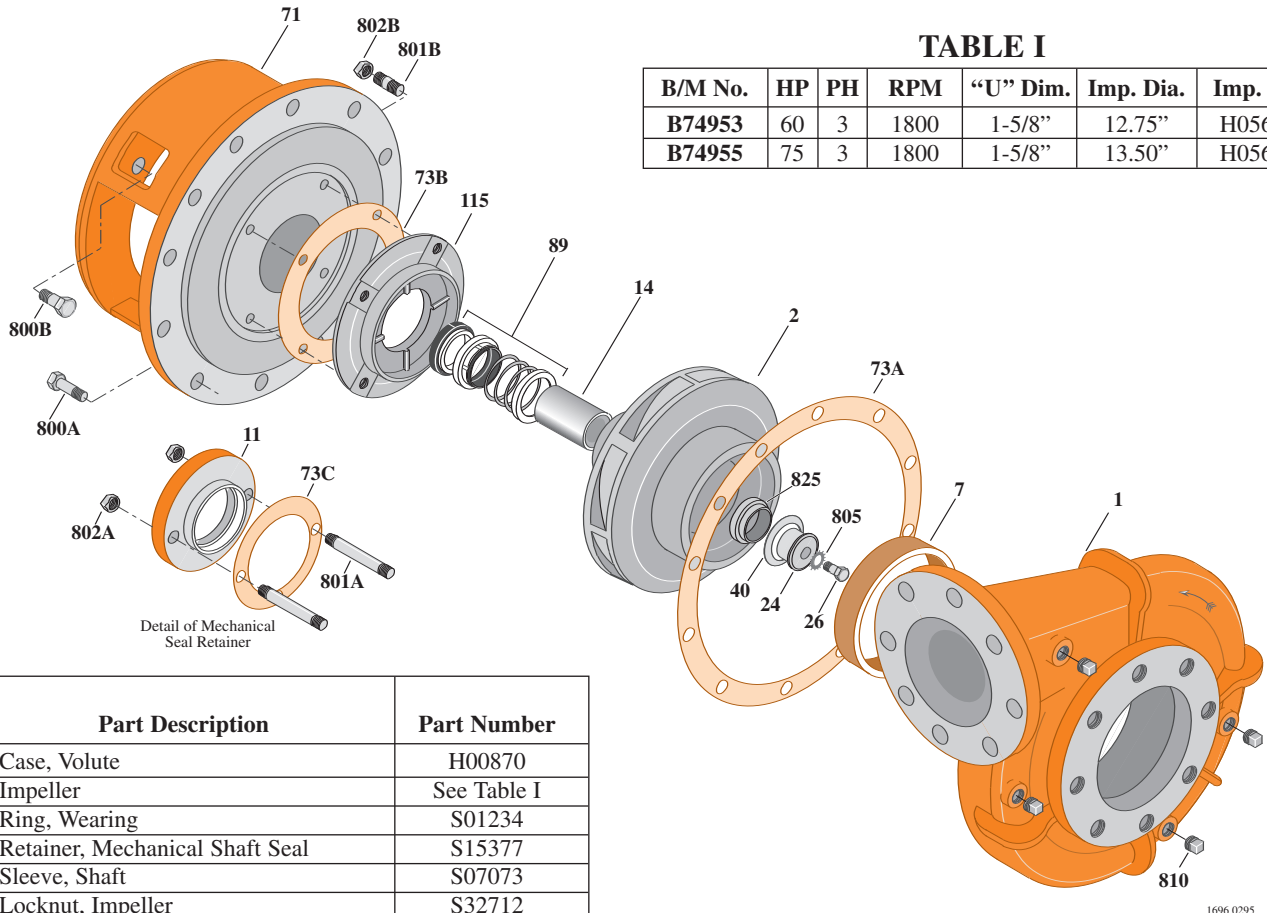

TABLE I

B/M No.	HP	PH	RPM	"U" Dim.	Imp. Dia.	Imp. No.
B74953	60	3	1800	1-5/8"	12.75"	H05690
B74955	75	3	1800	1-5/8"	13.50"	H05691

Item No.	Part Description	Part Number
1	Case, Volute	H00870
2	Impeller	See Table I
7	Ring, Wearing	S01234
11	Retainer, Mechanical Shaft Seal	S15377
14	Sleeve, Shaft	S07073
24	Locknut, Impeller	S32712
26	Screw, Impeller 1/2 - 13 x 2-1/2"	S23629
32	Key, 3/8 x 2-1/4" (See Note)	S23940
40	Deflector	S19864
71	Bracket	See Table II
73A	Gasket, Volute Case	S06271
73B	Gasket, Balance Ring	S09943
73C	Gasket, Seal Retainer	S15078
89	Seal, Mechanical Shaft	S32016
115	Ring, Balance	S12334
800A	Cap screw, 5/8 - 11 x 1-1/2" (12 Req.)	S26999
800B	Cap screw, 5/8 - 11 x 1-3/4" (4 Req.)	S27001
801A	Stud, 3/8 - 16 x 2-1/2" (2 Req.)	S04438
802A	Nut, 3/8 - 16 (2 Req.)	S23343
801B	Stud, 3/8 - 16 x 1-3/4" (4 Req.)	S23996
802B	Nut, 3/8 - 16 (4 Req.)	S23103
805	Washer, Lock	S23038
810	Plug, Pipe 1/2" NPT (4 Req.)	S23717
825	Sleeve, Impeller Locknut	S31661
•	Plug, Pipe 1/8" NPT(In Bracket)(2 Req.)	S23714

TABLE II

HP	PH	Bracket No.	"AK" Fit	"U" Dim.	Motor Frame
60	3	H03936	12-1/2"	1-5/8"	364JP
75	3	H03936	12-1/2"	1-5/8"	365JP

NOTE: For an explanation of the tabulated material found on this page and for impeller key location, refer to *Supplement A* located at the beginning of this section.

NOTE: For seal flush line details, see *Supplement D*.

• Not illustrated.