



# TYPE "B" SINGLE STAGE CENTRIFUGAL PUMP Electric Motor Drive

Section	CC
Page	400.1
Date	January 1, 2004
Supersedes 6/1/95	

## CAST IRON IMPELLER

## B6EXPBL

### Flanged Case

### Packing Construction

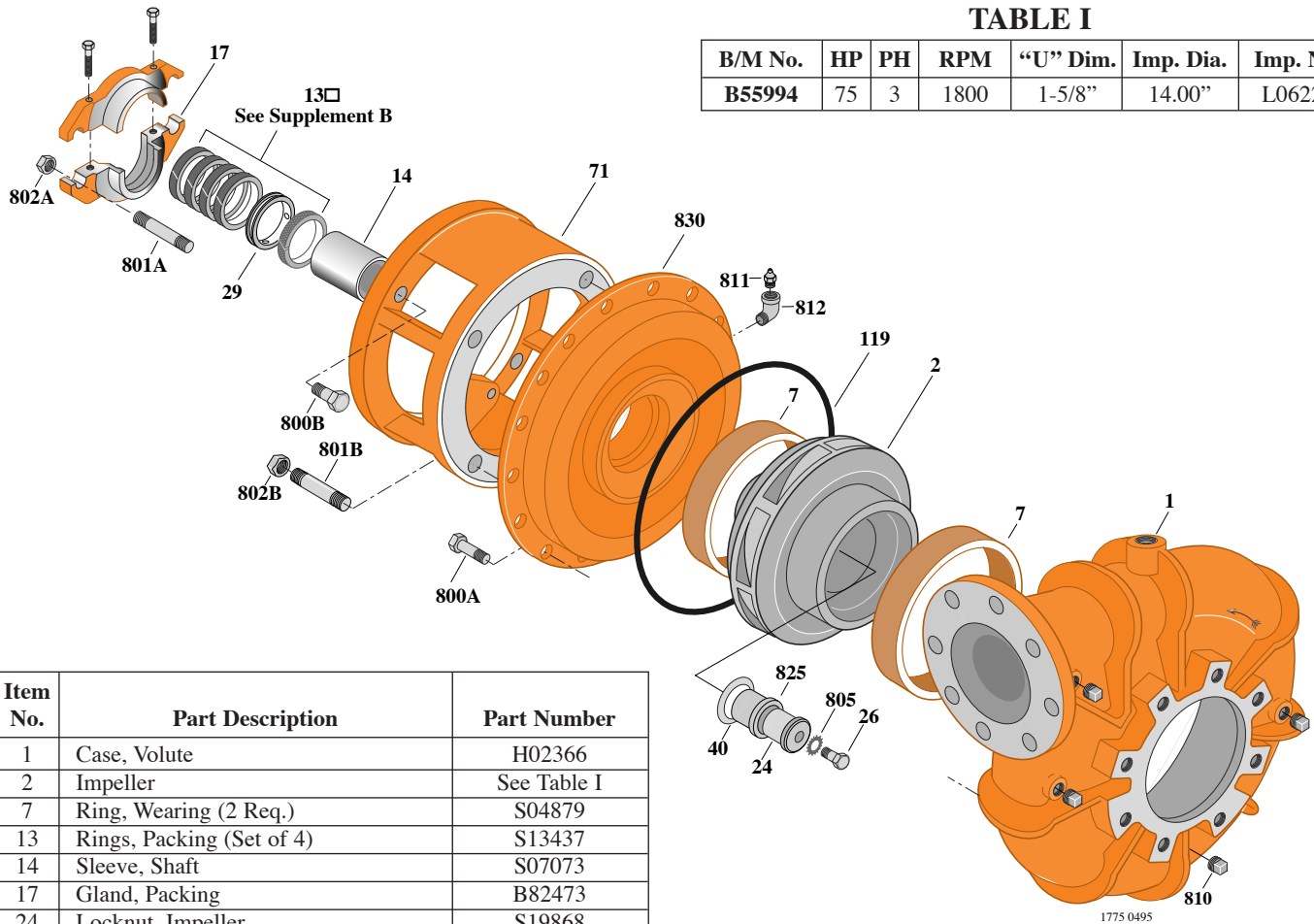

**TABLE I**

B/M No.	HP	PH	RPM	"U" Dim.	Imp. Dia.	Imp. No.
B55994	75	3	1800	1-5/8"	14.00"	L06225

Item No.	Part Description	Part Number
1	Case, Volute	H02366
2	Impeller	See Table I
7	Ring, Wearing (2 Req.)	S04879
13	Rings, Packing (Set of 4)	S13437
14	Sleeve, Shaft	S07073
17	Gland, Packing	B82473
24	Locknut, Impeller	S19868
26	Screw, Impeller 1/2 - 13 x 3-1/2"	S23633
29	Ring, Lantern	S19198
32	Key, 3/8 x 2-1/4" (See Note)	S23940
40	Deflector	S19864
71	Bracket	See Table II
119	O-Ring	S14444
800A	Capscrew, 5/8 - 11 x 1-1/2" (16 Req.)	S26999
800B	Capscrew, 5/8 - 11 x 1-3/4" (4 Req.)	S27001
801A	Stud, 1/2 - 13 x 3-3/4" (2 Req.)	S08305
801B	Stud, 3/4 - 10 x 2-1/4" (4 Req.)	S23078
802A	Nut, Hex 1/2 - 13 x 7/16" (2 Req.)	S23347
802B	Nut, Hex 3/4 - 10 (4 Req.)	S23111
805	Washer, Lock	S23038
810	Plug, Pipe 1/2 NPT (4 Req.)	S23717
811	Fitting, Grease	S23700
812	Elbow, Street	S27401
825	Sleeve, Impeller Locknut	S19865
830	Cover, Case	H02482

**TABLE II**

HP	PH	Bracket No.	"AK" Fit	"U" Dim.	Motor Frame
75	3	H03688	12-1/2"	1-5/8"	365JP

**NOTE:** For an explanation of the tabulated material found on this page and for impeller key location, refer to *Supplement A* located at the beginning of this section.



# TYPE "B" SINGLE STAGE CENTRIFUGAL PUMP Electric Motor Drive

Section	CC
Page	400.2
Date	January 1, 2004
Supersedes 6/1/95	

## CAST IRON IMPELLER

## B6EXPBL

### Flanged Case

### Packing Construction

**TABLE I**

B/M No.	HP	PH	RPM	"U" Dim.	Imp. Dia.	Imp. No.
B55995	100	3	1800	1-5/8"	15.25"	L06226
B55995MS1	125	3	1800	1-5/8"	15.50"	L05156

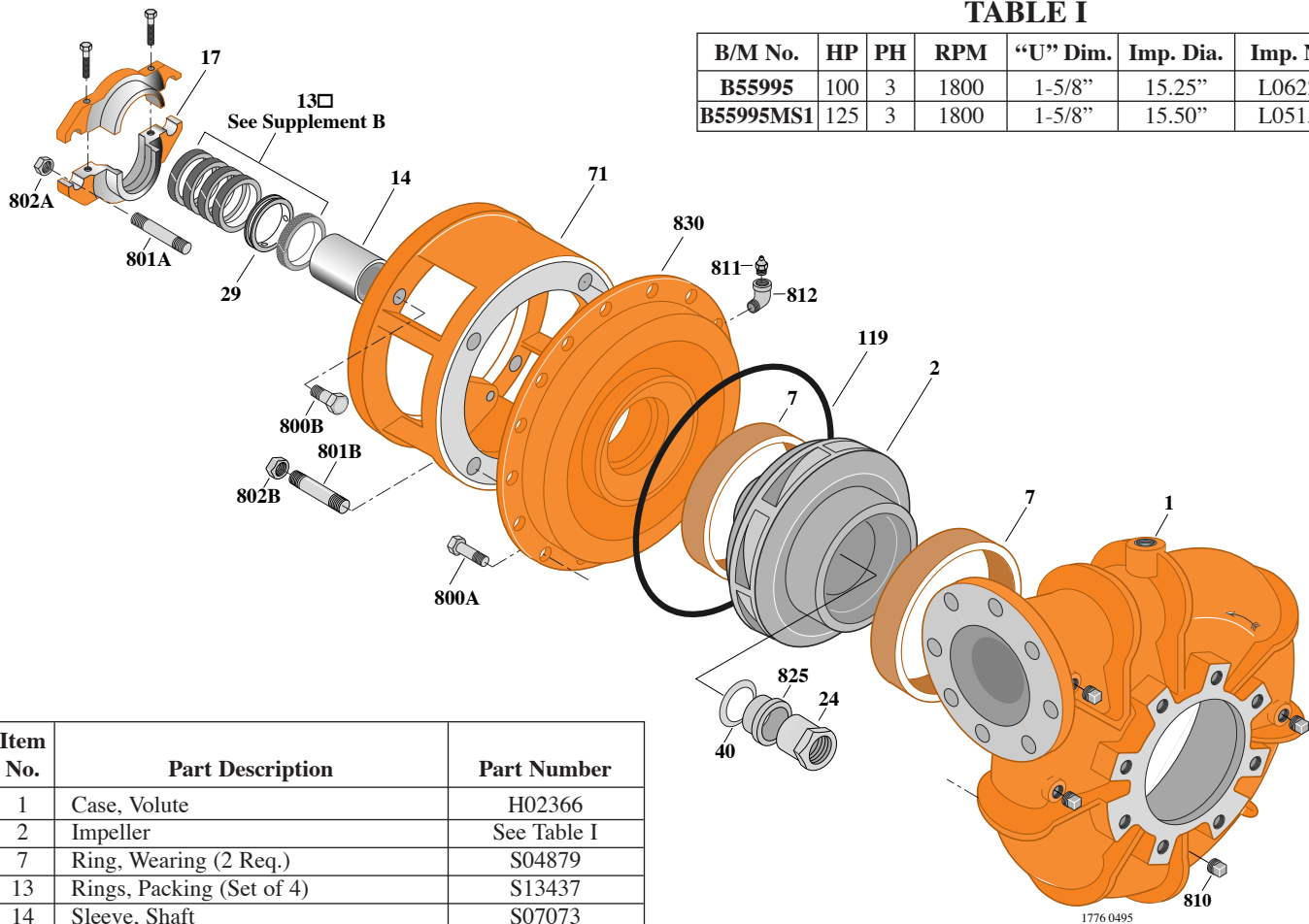

Item No.	Part Description	Part Number
1	Case, Volute	H02366
2	Impeller	See Table I
7	Ring, Wearing (2 Req.)	S04879
13	Rings, Packing (Set of 4)	S13437
14	Sleeve, Shaft	S07073
17	Gland, Packing	B82473
24	Locknut, Impeller	S19863
29	Ring, Lantern	S19198
32	Key, 3/8 x 2-1/4" (See Note)	S23940
40	Deflector	S19864
71	Bracket	See Table II
119	O-Ring	S14444
800A	Capscrew, 5/8 - 11 x 1-1/2" (16 Req.)	S26999
800B	Capscrew, 5/8 - 11 x 1-3/4" (4 Req.)	S27001
801A	Stud, 1/2 - 13 x 3-3/4" (2 Req.)	S08305
801B	Stud, 3/4 - 10 x 2-1/4" (4 Req.)	S24078
802A	Nut, Hex 1/2 - 13 x 7/16" (2 Req.)	S23347
802B	Nut, Hex 3/4 - 10 (4 Req.)	S23111
810	Plug, Pipe 1/2 NPT (4 Req.)	S23717
811	Fitting, Grease	S23700
812	Elbow, Street	S27401
825	Sleeve, Impeller Locknut	S19865
830	Cover, Case	H02482

**TABLE II**

HP	PH	Bracket No.	"AK" Fit	"U" Dim.	Motor Frame
100	3	H03688	12-1/2"	1-5/8"	404TC
125	3	H03688	12-1/2"	1-5/8"	405TC

**NOTE:** For an explanation of the tabulated material found on this page and for impeller key location, refer to *Supplement A* located at the beginning of this section.



# TYPE "B" SINGLE STAGE CENTRIFUGAL PUMP Electric Motor Drive

Section	CC
Page	400.3
Date	January 1, 2004
Supersedes 6/1/95	

## CAST IRON IMPELLER

## B6EXPBLS

### Flanged Case

### Mechanical Shaft Seal Construction

**TABLE I**

B/M No.	HP	PH	RPM	"U" Dim.	Imp. Dia.	Imp. No.
<b>B68434</b>	75	3	1800	1-5/8"	14.00"	L06225

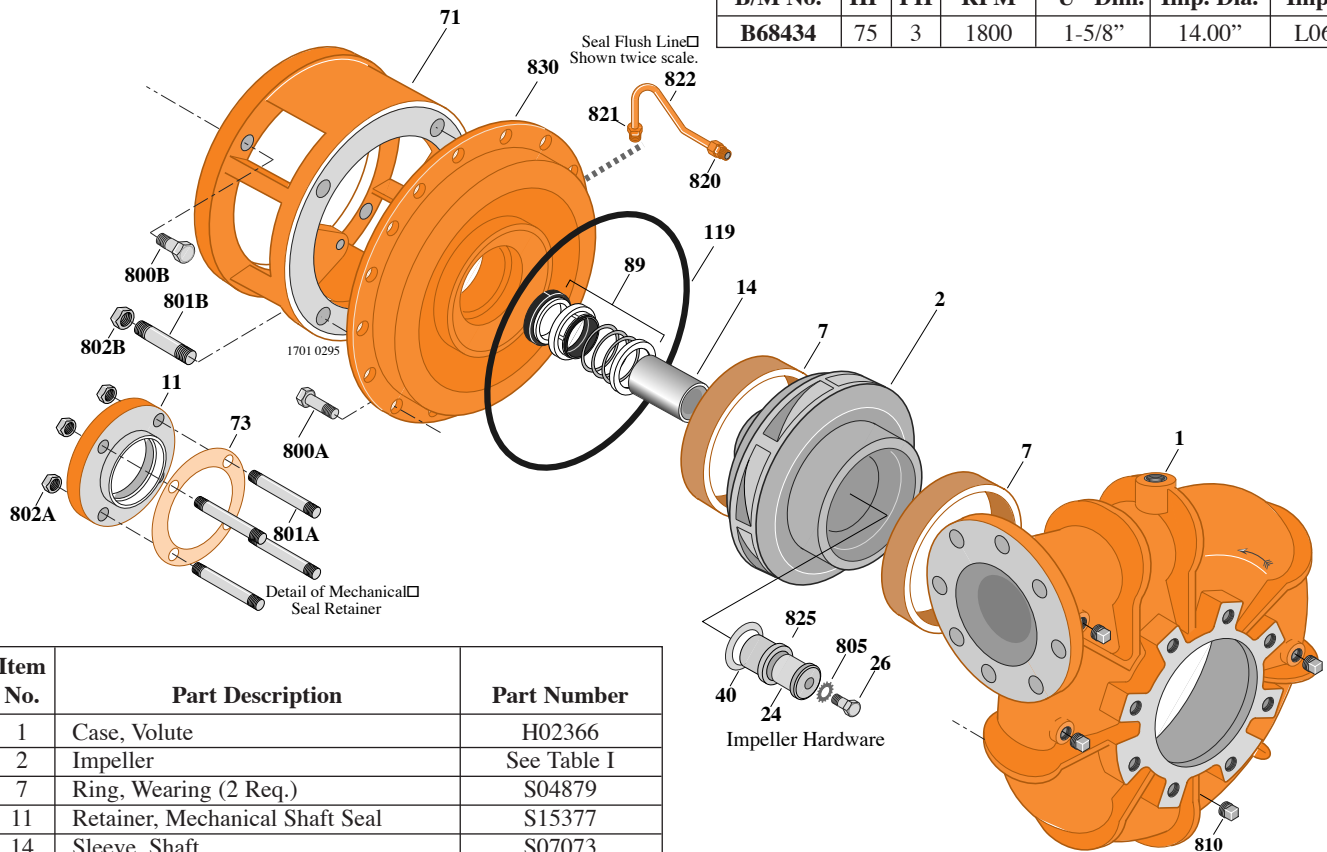

Item No.	Part Description	Part Number
1	Case, Volute	H02366
2	Impeller	See Table I
7	Ring, Wearing (2 Req.)	S04879
11	Retainer, Mechanical Shaft Seal	S15377
14	Sleeve, Shaft	S07073
24	Locknut, Impeller	S19868
26	Screw, Impeller 1/2 - 13 x 3-1/2"	S23633
32	Key, 3/8 x 2-1/2" (See Note)	S23941
40	Deflector	S19864
71	Bracket	See Table II
73	Gasket, Seal Retainer	S16411
89	Seal, Mechanical Shaft	S32016
119	O-Ring	S14444
800A	Capscrew, 5/8 - 11 x 1-1/2" (16 Req.)	S26999
800B	Capscrew, 5/8 - 11 x 1-3/4" (4 Req.)	S27001
801A	Stud, 3/8 - 16 x 1-3/4" (4 Req.)	S04435
801B	Stud, 3/4 - 10 x 2-1/4" (4 Req.)	S24078
802A	Nut, 3/8 - 16 (2 Req.)	S23343
802B	Nut, 3/4 - 10 (4 Req.)	S23111
805	Washer, Lock	S23038
810	Plug, Pipe 1/2 NPT (4 Req.)	S23717
820	Connector, Comp. Fitting	S24013
821	Elbow, Comp. Tube Fitting	S24128
822	Tubing, Copper	S20677
825	Sleeve, Impeller Locknut	S19865
830	Cover, Case	H02761

**TABLE II**

HP	PH	Bracket No.	"AK" Fit	"U" Dim.	Motor Frame
75	3	H05058	12-1/2"	1-5/8"	365JP

**NOTE:** For an explanation of the tabulated material found on this page and for impeller key location, refer to *Supplement A* located at the beginning of this section.



# TYPE "B" SINGLE STAGE CENTRIFUGAL PUMP Electric Motor Drive

Section	CC
Page	400.4
Date	January 1, 2004
Supersedes 6/1/95	

## CAST IRON IMPELLER

## B6EXPBLS

### Flanged Case

### Mechanical Shaft Seal Construction

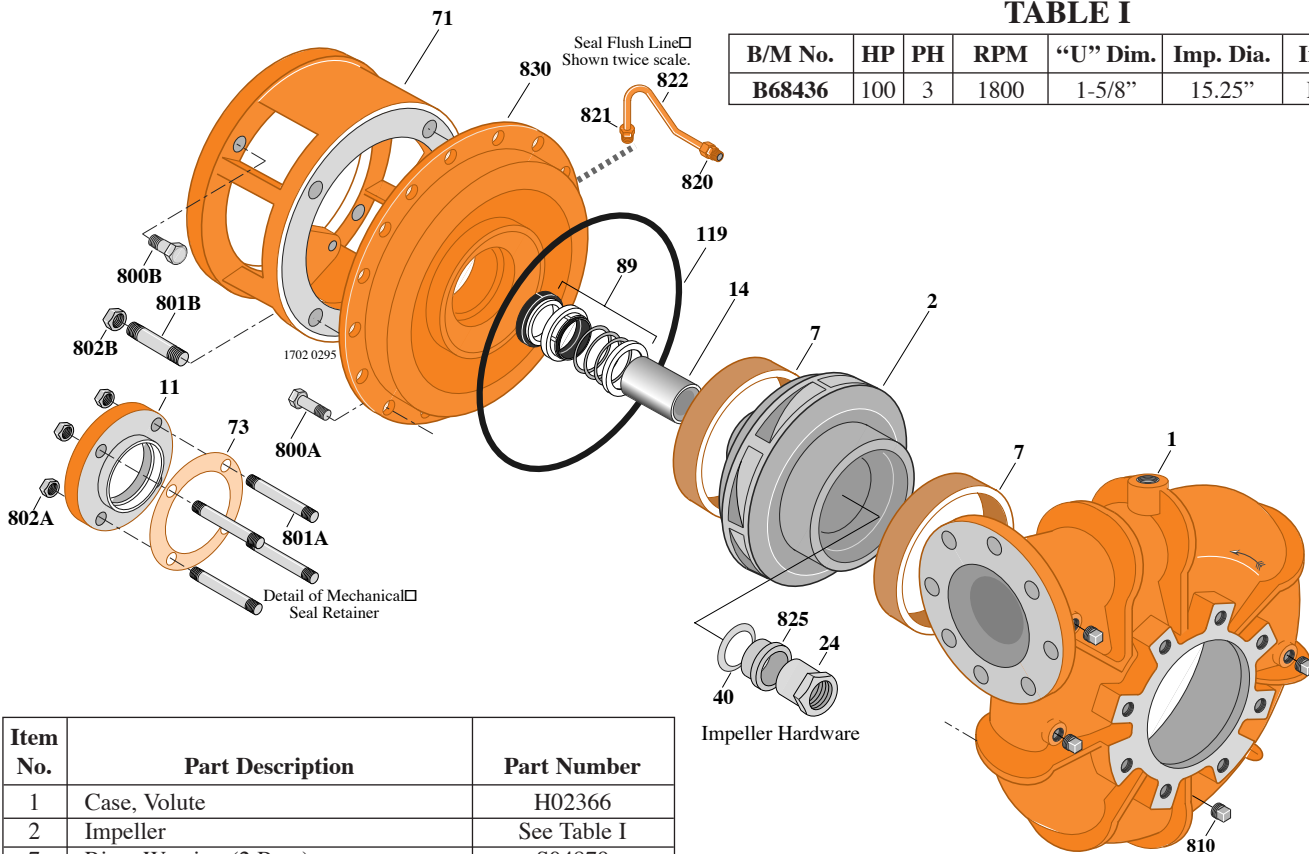

TABLE I

B/M No.	HP	PH	RPM	"U" Dim.	Imp. Dia.	Imp. No.
B68436	100	3	1800	1-5/8"	15.25"	L06226

Item No.	Part Description	Part Number
1	Case, Volute	H02366
2	Impeller	See Table I
7	Ring, Wearing (2 Req.)	S04879
11	Retainer, Mechanical Shaft Seal	S15377
14	Sleeve, Shaft	S07073
24	Locknut, Impeller	S19863
32	Key, 3/8 x 2-1/2" (See Note)	S23941
40	Deflector	S19864
71	Bracket	See Table II
73	Gasket, Seal Retainer	S16411
89	Seal, Mechanical Shaft	S32016
119	O-Ring	S14444
800A	Capscrew, 5/8 - 11 x 1-1/2" (16 Req.)	S26999
800B	Capscrew, 5/8 - 11 x 1-3/4" (4 Req.)	S27001
801A	Stud, 3/8 - 16 x 1-3/4" (4 Req.)	S04435
801B	Stud, 3/4 - 10 x 2-1/4" (4 Req.)	S24078
802A	Nut, 3/8 - 16 (2 Req.)	S23343
802B	Nut, 3/4 - 10 (4 Req.)	S23111
810	Plug, Pipe 1/2 NPT (4 Req.)	S23717
820	Connector, Comp. Fitting	S24013
821	Elbow, Comp. Tube Fitting	S24128
822	Tubing, Copper	S20677
825	Sleeve, Impeller Locknut	S19865
830	Cover, Case	H02761

TABLE II

HP	PH	Bracket No.	"AK" Fit	"U" Dim.	Motor Frame
100	3	H05058	12-1/2"	1-5/8"	404TC

**NOTE:** For an explanation of the tabulated material found on this page and for impeller key location, refer to *Supplement A* located at the beginning of this section.