



TYPE "B" SINGLE STAGE CENTRIFUGAL PUMP Electric Motor Drive

Section	CC
Page	330.1
Date	June 1, 1995
Supersedes/New	

BRONZE IMPELLER

B5WP

Flanged Case

Packing Construction

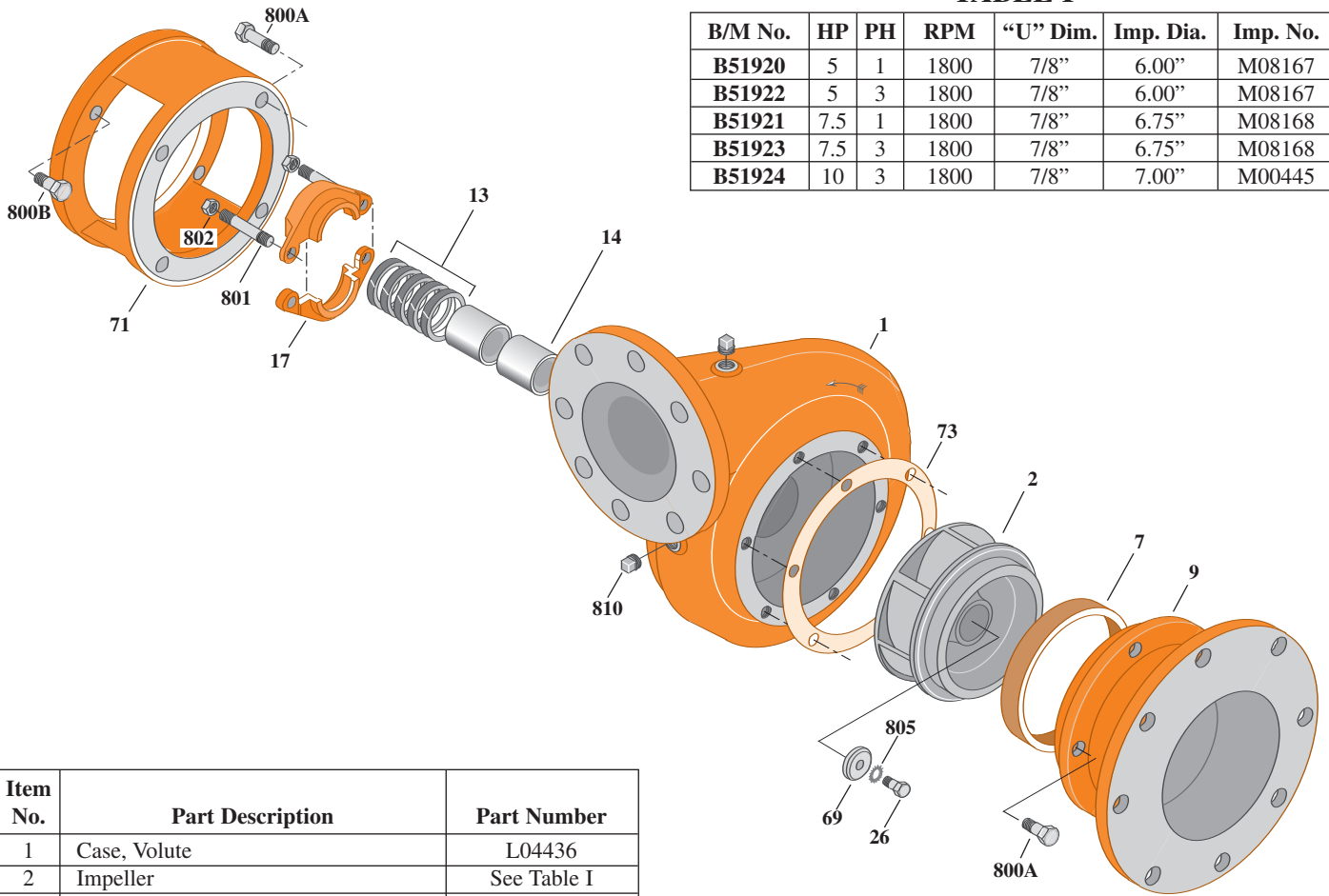

TABLE I

B/M No.	HP	PH	RPM	"U" Dim.	Imp. Dia.	Imp. No.
B51920	5	1	1800	7/8"	6.00"	M08167
B51922	5	3	1800	7/8"	6.00"	M08167
B51921	7.5	1	1800	7/8"	6.75"	M08168
B51923	7.5	3	1800	7/8"	6.75"	M08168
B51924	10	3	1800	7/8"	7.00"	M00445

Item No.	Part Description	Part Number
1	Case, Volute	L04436
2	Impeller	See Table I
7	Ring, Wearing	S04457
9	Cover, Suction	M05873
13	Rings, Packing (Set of 5)	S14109
14	Sleeve, Shaft (2 Req.)	S00619
17	Gland, Packing	S00393
26	Screw, Impeller 3/8 - 16 x 1"	S23566
32	Key, 3/16 x 1-1/4" (See Note)	S34383
69	Washer, Impeller	S06314
71	Bracket	See Table II
73	Gasket, Suction Cover	S01559
800A	Capscrew, 3/8 - 16 x 1" (10 Req.)	S26826
800B	Capscrew, 1/2 - 13 x 1-1/4" (4 Req.)	S26914
801	Stud, 3/8 - 16 x 3-1/4" (2 Req.)	S04440
802	Nut, Hex 3/8 - 16 (2 Req.)	S23343
805	Washer, Lock	S23036
810A	Plug, Pipe 1/4 NPT (4 Req.)	S23715
•	Plug, Pipe 1/2 NPT (Not Illustrated) (On Suction Cover)	S23717

TABLE II

HP	PH	Bracket No.	"AK" Fit	"U" Dim.	Motor Frame
5	1	M00631	8-1/2"	7/8"	213TC
5	3	M00631	8-1/2"	7/8"	184TC
7.5	1	M00631	8-1/2"	7/8"	215TC
7.5	3	M00631	8-1/2"	7/8"	213TC
10	3	M00631	8-1/2"	7/8"	215TC

NOTE: For an explanation of the tabulated material found on this page and for impeller key location, refer to *Supplement A* located at the beginning of this section.



TYPE "B" SINGLE STAGE CENTRIFUGAL PUMP Electric Motor Drive

Section	CC
Page	330.2
Date	June 1, 1995
Supersedes/New	

BRONZE IMPELLER

B5WPS

Flanged Case

Mechanical Shaft Seal Construction

TABLE I

B/M No.	HP	PH	RPM	"U" Dim.	Imp. Dia.	Imp. No.
B62577	5	1	1800	7/8"	6.00"	M08167
B68315	5	3	1800	7/8"	6.00"	M08167
B62579	7.5	1	1800	7/8"	6.75"	M08168
B62580	7.5	3	1800	7/8"	6.75"	M08168
B68316	10	1	1800	7/8"	7.00"	M00445
B62581	10	3	1800	7/8"	7.00"	M00445

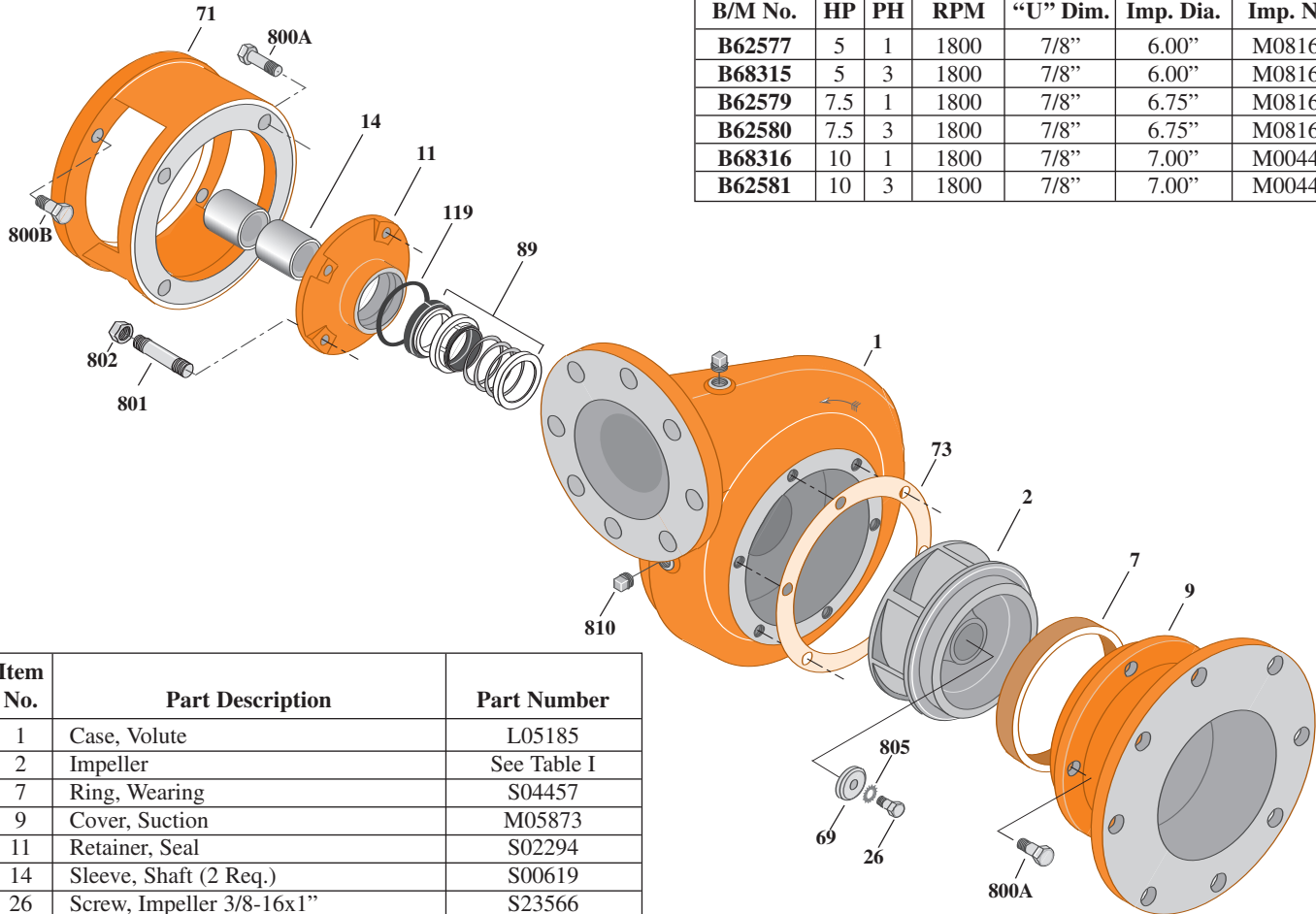

Item No.	Part Description	Part Number
1	Case, Volute	L05185
2	Impeller	See Table I
7	Ring, Wearing	S04457
9	Cover, Suction	M05873
11	Retainer, Seal	S02294
14	Sleeve, Shaft (2 Req.)	S00619
26	Screw, Impeller 3/8-16x1"	S23566
32	Key, 3/16x1-1/4" (See Note)	S34383
69	Washer, Lock	S06314
71	Bracket	See Table II
73	Gasket, Suction Cover	S01559
89	Seal, Mechanical Shaft	S32013
119	O-Ring	S14804
800A	Capscrew, 3/8-16x1" (10 Req.)	S26826
800B	Capscrew, 1/2-13x1-1/4" (4 Req.)	S26914
801	Stud, 3/8-16x3" (4 Req.)	S04439
802	Nut, Hex 3/8-16 (4 Req.)	S23343
805	Washer, Lock	S23036
810	Plug, Pipe 1/4 NPT (5 Req.)	S23715
820	Connector, Comp. Fitting	S24013
821	Elbow, Tubing	S24129
822	Tubing, Copper	S20677
•	Plug, Pipe 1/2 NPT (On Suction Cover) (Not Illustrated)	S23717

TABLE II

HP	PH	Bracket No.	"AK" Fit	"U" Dim.	Motor Frame
5	1	M00631	8-1/2"	7/8"	213TC
5	3	M00631	8-1/2"	7/8"	184TC
7.5	1	M00631	8-1/2"	7/8"	215TC
7.5	3	M00631	8-1/2"	7/8"	213TC
10	1	M00631	8-1/2"	7/8"	215TC
10	3	M00631	8-1/2"	7/8"	215TC

NOTE: For an explanation of the tabulated material found on this page and for impeller key location, refer to *Supplement A* located at the beginning of this section.



TYPE "B" SINGLE STAGE CENTRIFUGAL PUMP Electric Motor Drive

Section	CC
Page	330.3
Date	September 1, 1995
Supersedes/New	

SILICON BRONZE IMPELLER

B5WP

Flanged Case

Packing Construction

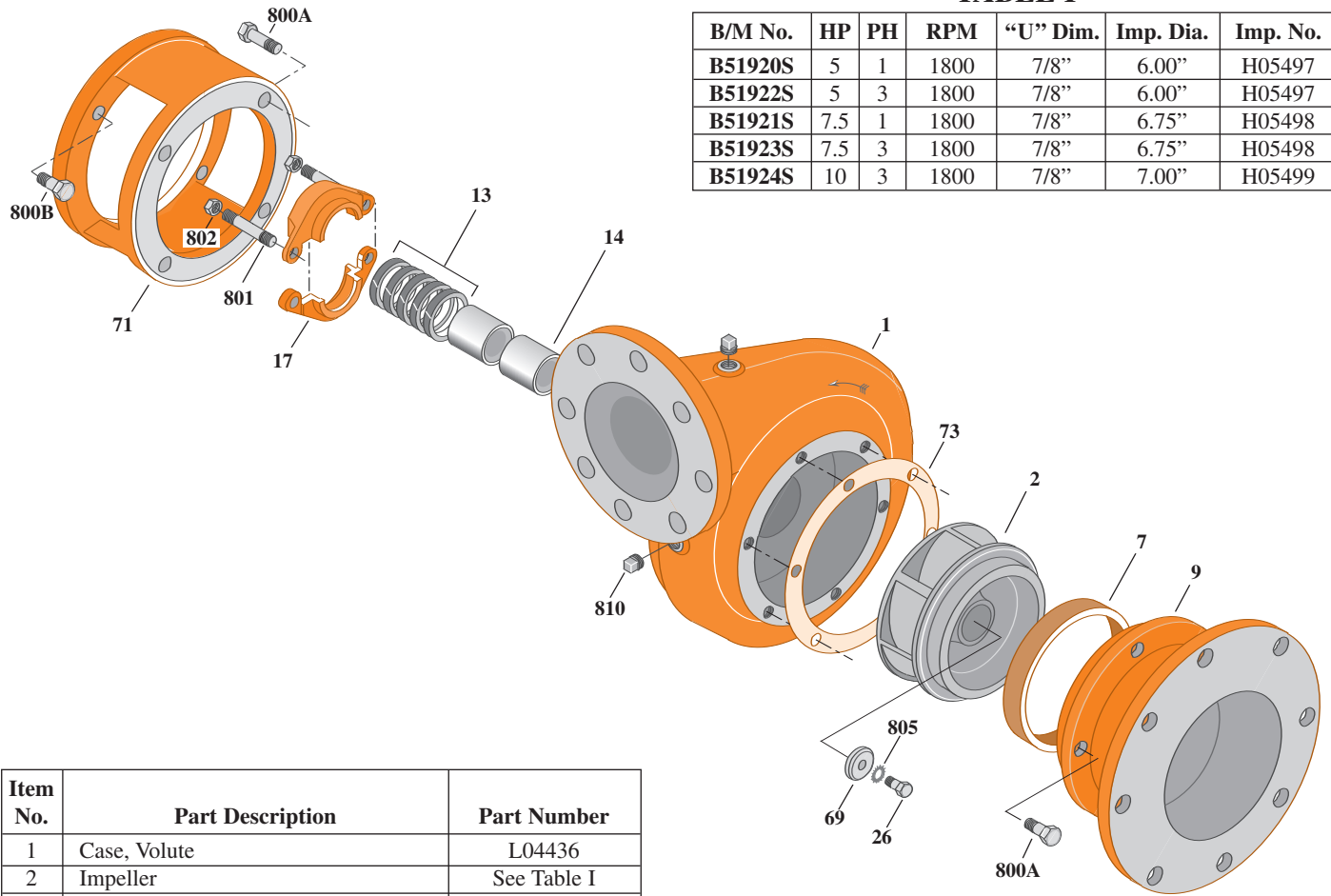

TABLE I

B/M No.	HP	PH	RPM	"U" Dim.	Imp. Dia.	Imp. No.
B51920S	5	1	1800	7/8"	6.00"	H05497
B51922S	5	3	1800	7/8"	6.00"	H05497
B51921S	7.5	1	1800	7/8"	6.75"	H05498
B51923S	7.5	3	1800	7/8"	6.75"	H05498
B51924S	10	3	1800	7/8"	7.00"	H05499

Item No.	Part Description	Part Number
1	Case, Volute	L04436
2	Impeller	See Table I
7	Ring, Wearing	S04457
9	Cover, Suction	M05873
13	Rings, Packing (Set of 5)	S14109
14	Sleeve, Shaft (2 Req.)	S00619
17	Gland, Packing	S00393
26	Screw, Impeller 3/8 - 16 x 1"	S23566
32	Key, 3/16 x 1-1/4" (See Note)	S34383
69	Washer, Impeller	S06314
71	Bracket	See Table II
73	Gasket, Suction Cover	S01559
800A	Capscrew, 3/8 - 16 x 1" (10 Req.)	S26826
800B	Capscrew, 1/2 - 13 x 1-1/4" (4 Req.)	S26914
801	Stud, 3/8 - 16 x 3-1/4" (2 Req.)	S04440
802	Nut, Hex 3/8 - 16 (2 Req.)	S23343
805	Washer, Lock	S23036
810A	Plug, Pipe 1/4 NPT (4 Req.)	S23715
•	Plug, Pipe 1/2 NPT (Not Illustrated) (On Suction Cover)	S23717

TABLE II

HP	PH	Bracket No.	"AK" Fit	"U" Dim.	Motor Frame
5	1	M00631	8-1/2"	7/8"	213TC
5	3	M00631	8-1/2"	7/8"	184TC
7.5	1	M00631	8-1/2"	7/8"	215TC
7.5	3	M00631	8-1/2"	7/8"	213TC
10	3	M00631	8-1/2"	7/8"	215TC

NOTE: For an explanation of the tabulated material found on this page and for impeller key location, refer to *Supplement A* located at the beginning of this section.



TYPE "B" SINGLE STAGE CENTRIFUGAL PUMP Electric Motor Drive

Section	CC
Page	330.4
Date	September 1, 1995
Supersedes/New	

SILICON BRONZE IMPELLER

B5WPS

Flanged Case

Mechanical Shaft Seal Construction

TABLE I

B/M No.	HP	PH	RPM	"U" Dim.	Imp. Dia.	Imp. No.
B62577S	5	1	1800	7/8"	6.00"	H05497
B68315S	5	3	1800	7/8"	6.00"	H05497
B62579S	7.5	1	1800	7/8"	6.75"	H05498
B62580S	7.5	3	1800	7/8"	6.75"	H05498
B68316S	10	1	1800	7/8"	7.00"	H05499
B62581S	10	3	1800	7/8"	7.00"	H05499

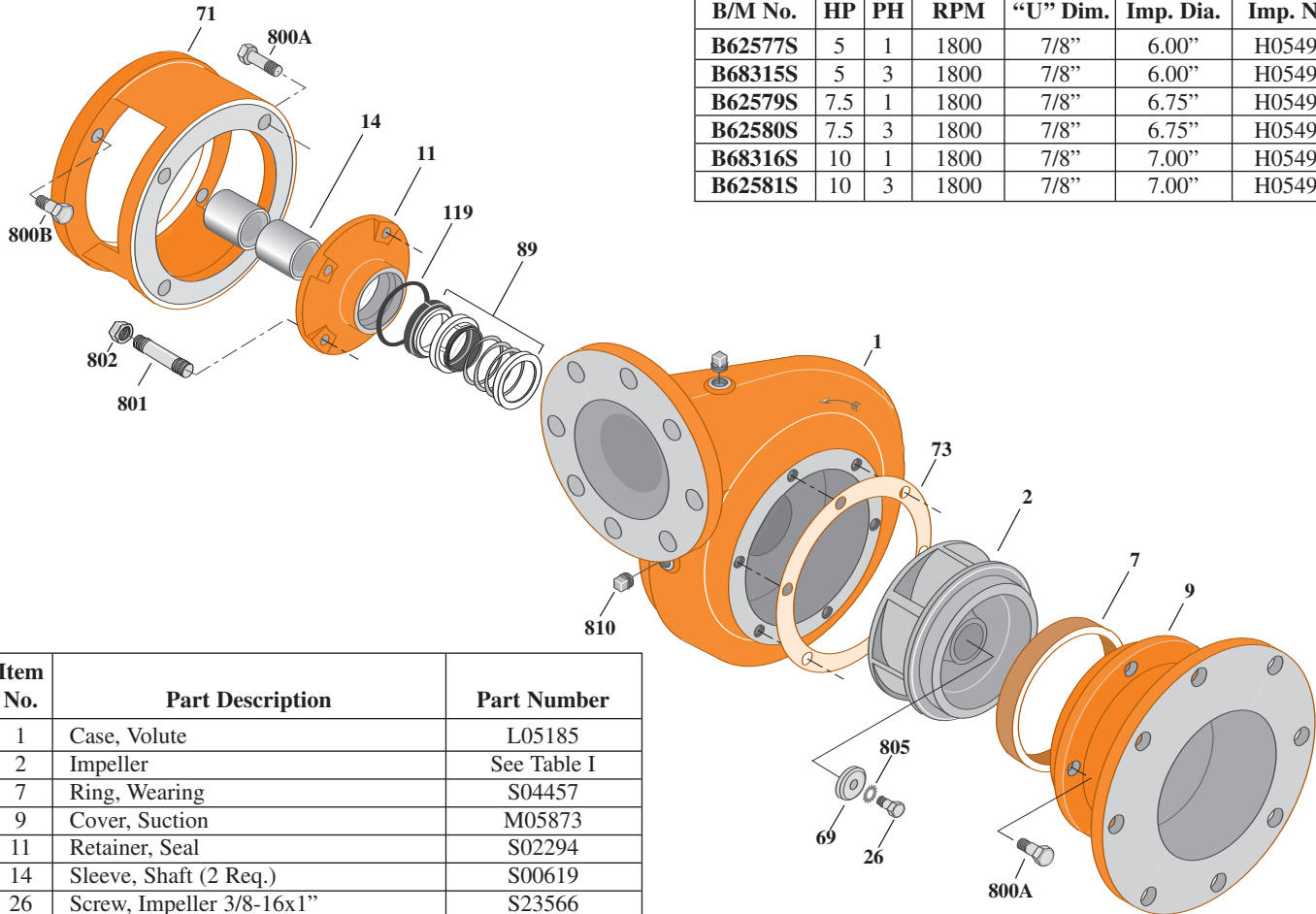

Item No.	Part Description	Part Number
1	Case, Volute	L05185
2	Impeller	See Table I
7	Ring, Wearing	S04457
9	Cover, Suction	M05873
11	Retainer, Seal	S02294
14	Sleeve, Shaft (2 Req.)	S00619
26	Screw, Impeller 3/8-16x1"	S23566
32	Key, 3/16x1-1/4" (See Note)	S34383
69	Washer, Lock	S06314
71	Bracket	See Table II
73	Gasket, Suction Cover	S01559
89	Seal, Mechanical Shaft	S32013
119	O-Ring	S14804
800A	Capscrew, 3/8-16x1" (10 Req.)	S26826
800B	Capscrew, 1/2-13x1-1/4" (4 Req.)	S26914
801	Stud, 3/8-16x3" (4 Req.)	S04439
802	Nut, Hex 3/8-16 (4 Req.)	S23343
805	Washer, Lock	S23036
810	Plug, Pipe 1/4 NPT (5 Req.)	S23715
820	Connector, Comp. Fitting	S24013
821	Elbow, Tubing	S24129
822	Tubing, Copper	S20677
•	Plug, Pipe 1/2 NPT (On Suction Cover) (Not Illustrated)	S23717

TABLE II

HP	PH	Bracket No.	"AK" Fit	"U" Dim.	Motor Frame
5	1	M00631	8-1/2"	7/8"	213TC
5	3	M00631	8-1/2"	7/8"	184TC
7.5	1	M00631	8-1/2"	7/8"	215TC
7.5	3	M00631	8-1/2"	7/8"	213TC
10	1	M00631	8-1/2"	7/8"	215TC
10	3	M00631	8-1/2"	7/8"	215TC

NOTE: For an explanation of the tabulated material found on this page and for impeller key location, refer to *Supplement A* located at the beginning of this section.



TYPE "B" SINGLE STAGE CENTRIFUGAL PUMP Electric Motor Drive

Section	CC
Page	330.5
Date	January 1, 2004
Supersedes 9/1/97	

SILICON BRONZE IMPELLER

B5WP

Flanged Case

Packing Construction

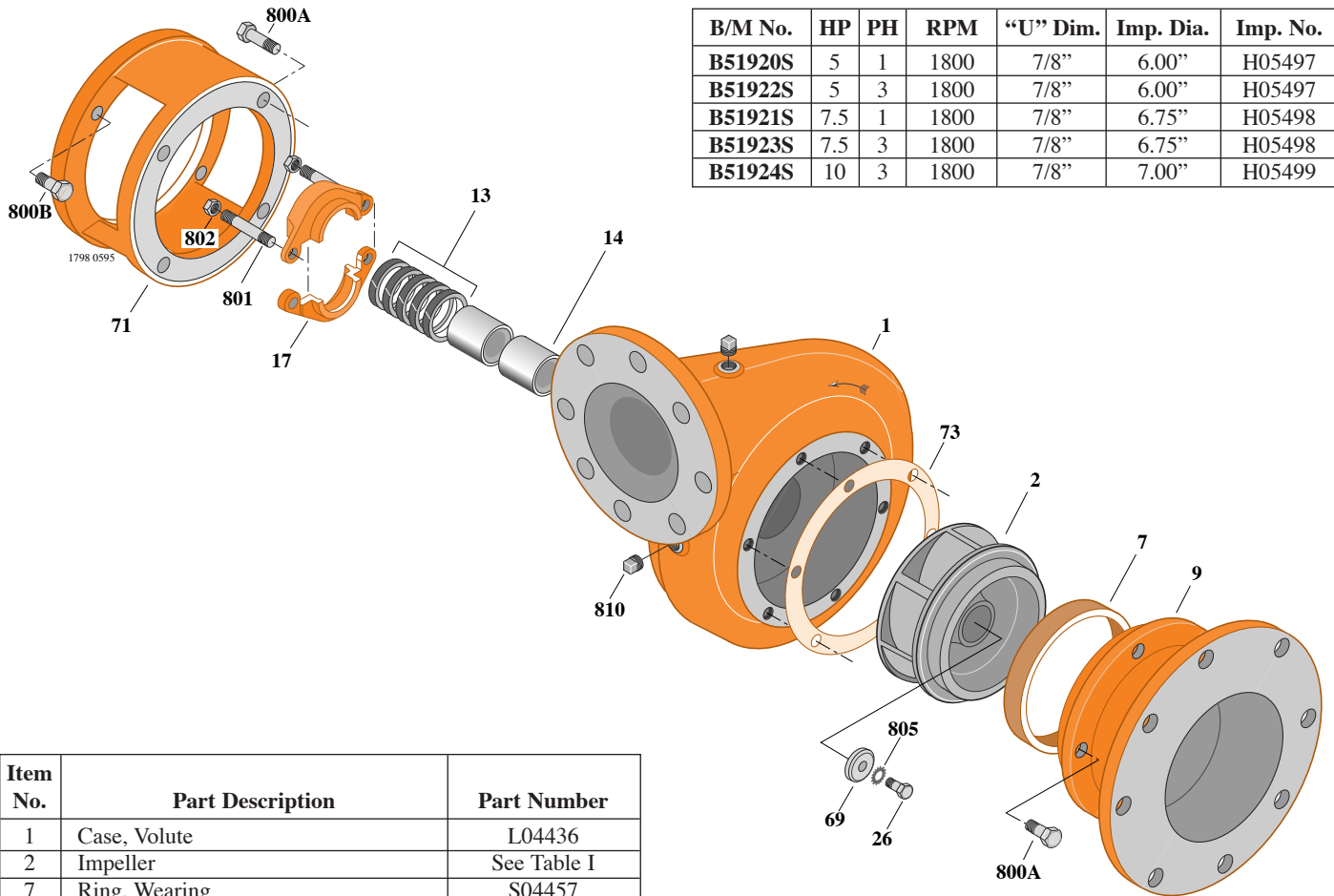

TABLE I

B/M No.	HP	PH	RPM	"U" Dim.	Imp. Dia.	Imp. No.
B51920S	5	1	1800	7/8"	6.00"	H05497
B51922S	5	3	1800	7/8"	6.00"	H05497
B51921S	7.5	1	1800	7/8"	6.75"	H05498
B51923S	7.5	3	1800	7/8"	6.75"	H05498
B51924S	10	3	1800	7/8"	7.00"	H05499

Item No.	Part Description	Part Number
1	Case, Volute	L04436
2	Impeller	See Table I
7	Ring, Wearing	S04457
9	Cover, Suction	M05873
13	Rings, Packing (Set of 5)	S14109
14	Sleeve, Shaft (2 Req.)	S00619
17	Gland, Packing	B82469
26	Screw, Impeller 3/8 - 16 x 1"	S23566
32	Key, 3/16 x 1-1/4" (See Note)	S34383
69	Washer, Impeller	S06314
71	Bracket	See Table II
73	Gasket, Suction Cover	S01559
800A	Capscrew, 3/8 - 16 x 1" (10 Req.)	S26826
800B	Capscrew, 1/2 - 13 x 1-1/4" (4 Req.)	S26914
801	Stud, 3/8 - 16 x 3-1/4" (2 Req.)	S04440
802	Nut, Hex 3/8 - 16 (2 Req.)	S23343
805	Washer, Lock	S23036
810	Plug, Pipe 1/4" NPT (4 Req.)	S23715
•	Plug, Pipe 1/2" NPT (Suction Cover)	S23717

TABLE II

HP	PH	Bracket No.	"AK" Fit	"U" Dim.	Motor Frame
5	1	M00631	8-1/2"	7/8"	213TC
5	3	M00631	8-1/2"	7/8"	184TC
7.5	1	M00631	8-1/2"	7/8"	215TC
7.5	3	M00631	8-1/2"	7/8"	213TC
10	3	M00631	8-1/2"	7/8"	215TC

NOTE: For an explanation of the tabulated material found on this page and for impeller key location, refer to *Supplement A* located at the beginning of this section.

• Not illustrated.



TYPE "B" SINGLE STAGE CENTRIFUGAL PUMP Electric Motor Drive

Section	CC
Page	330.6
Date	January 1, 2004
Supersedes 9/1/97	

SILICON BRONZE IMPELLER

B5WPS

Flanged Case

Mechanical Shaft Seal Construction

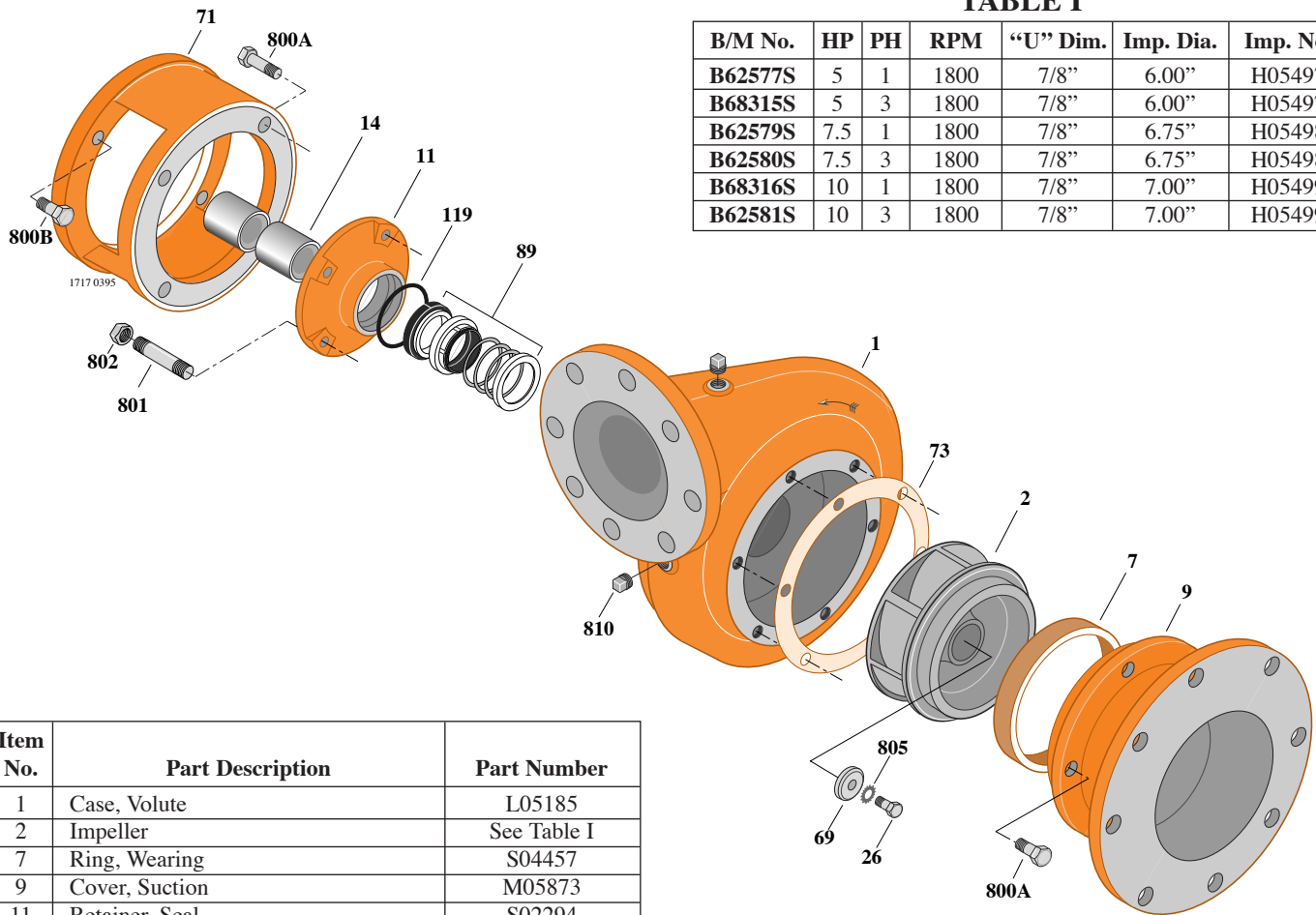

TABLE I

B/M No.	HP	PH	RPM	"U" Dim.	Imp. Dia.	Imp. No.
B62577S	5	1	1800	7/8"	6.00"	H05497
B68315S	5	3	1800	7/8"	6.00"	H05497
B62579S	7.5	1	1800	7/8"	6.75"	H05498
B62580S	7.5	3	1800	7/8"	6.75"	H05498
B68316S	10	1	1800	7/8"	7.00"	H05499
B62581S	10	3	1800	7/8"	7.00"	H05499

Item No.	Part Description	Part Number
1	Case, Volute	L05185
2	Impeller	See Table I
7	Ring, Wearing	S04457
9	Cover, Suction	M05873
11	Retainer, Seal	S02294
14	Sleeve, Shaft (2 Req.)	S00619
26	Screw, Impeller 3/8-16x1"	S23566
32	Key, 3/16x1-1/4" (See Note)	S34383
69	Washer, Lock	S06314
71	Bracket	See Table II
73	Gasket, Suction Cover	S01559
89	Seal, Mechanical Shaft	S32013
119	O-Ring	S14804
800A	Capscrew, 3/8-16x1" (10 Req.)	S26826
800B	Capscrew, 1/2-13x1-1/4" (4 Req.)	S26914
801	Stud, 3/8-16x3" (4 Req.)	S04439
802	Nut, Hex 3/8-16 (4 Req.)	S23343
805	Washer, Lock	S23036
810	Plug, Pipe 1/4" NPT (4 Req.)	S23715
•	Plug, Pipe 1/2" NPT (Suction Cover)	S23717
•	Plug, Pipe 1/8" NPT (Volute)	S23714

• Not illustrated.

TABLE II

HP	PH	Bracket No.	"AK" Fit	"U" Dim.	Motor Frame
5	1	M00631	8-1/2"	7/8"	213TC
5	3	M00631	8-1/2"	7/8"	184TC
7.5	1	M00631	8-1/2"	7/8"	215TC
7.5	3	M00631	8-1/2"	7/8"	213TC
10	1	M00631	8-1/2"	7/8"	215TC
10	3	M00631	8-1/2"	7/8"	215TC

NOTE: For an explanation of the tabulated material found on this page and for impeller key location, refer to *Supplement A* located at the beginning of this section.

NOTE: For seal flush line details, see *Supplement D*.