



TYPE "B" SINGLE STAGE CENTRIFUGAL PUMP Electric Motor Drive

Section	CC
Page	340.1
Date	January 1, 2004
Supersedes 6/1/95	

CAST IRON IMPELLER

B5EXPBH

Flanged Case

Packing Construction

TABLE I

B/M No.	HP	PH	RPM	"U" Dim.	Imp. Dia.	Imp. No.
B55988	100	3	1800	1-5/8"	14.38"	H03901
B55989	125	3	1800	1-5/8"	15.50"	H03433

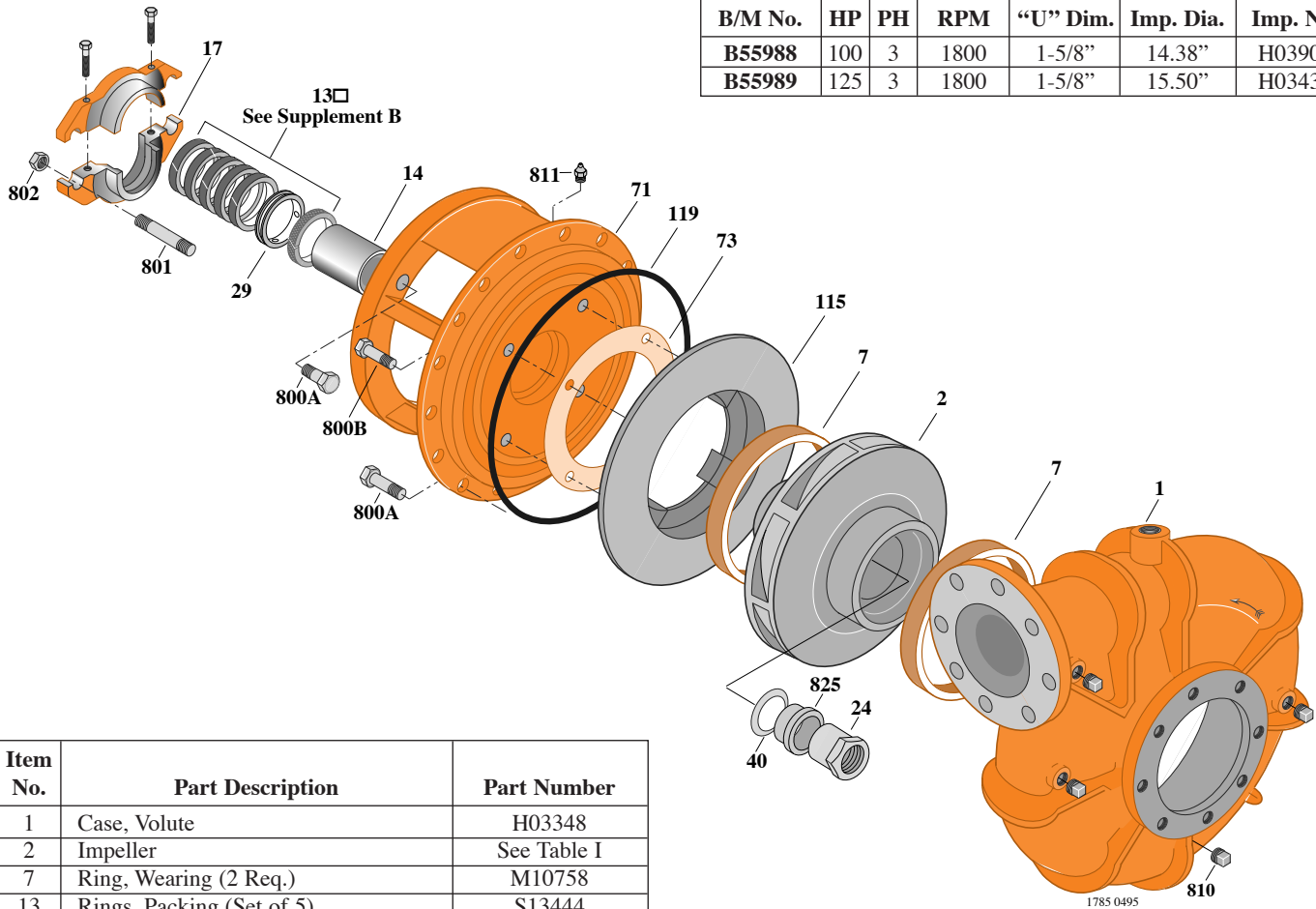

Item No.	Part Description	Part Number
1	Case, Volute	H03348
2	Impeller	See Table I
7	Ring, Wearing (2 Req.)	M10758
13	Rings, Packing (Set of 5)	S13444
14	Sleeve, Shaft	S07073
17	Gland, Packing	B82473
29	Ring, Lantern	S19198
32	Key, 3/8 x 2-1/4" (See Note)	S23940
40	Deflector	S19864
71	Bracket	See Table II
73	Gasket, Balance Ring	S09943
115	Ring, Balance	M06728
119	O-Ring	S14444
800A	Capscrew, 3/8 - 16 x 7/8" (4 Req.)	S26825
800B	Capscrew, 5/8 - 11 x 1-3/4" (20 Req.)	S27001
801	Stud, 1/2 - 13 x 3-3/4" (2 Req.)	S08305
802A	Nut, Hex 1/2 - 13 x 7/16" (2 Req.)	S23347
802B	Nut, Lock 1-1/4 - 12	S19863
810	Plug, Pipe 1/2 NPT (4 Req.)	S23717
811	Fitting, Grease	S23700
825	Sleeve, Impeller Locknut	S19865

TABLE II

HP	PH	Bracket No.	"AK" Fit	"U" Dim.	Motor Frame
100	3	H03684	12-1/2"	1-5/8"	404TC
125	3	H03684	12-1/2"	1-5/8"	405TC

NOTE: For an explanation of the tabulated material found on this page and for impeller key location, refer to *Supplement A* located at the beginning of this section.