



# TYPE "B" SINGLE STAGE CENTRIFUGAL PUMP Electric Motor Drive

Section	CC
Page	320.1
Date	January 1, 2004
Supersedes 6/1/95	

## BRONZE IMPELLER

## B5EPBM

### Flanged Case

### Packing Construction

**TABLE I**

B/M No.	HP	PH	RPM	"U" Dim.	Imp. Dia.	Imp. No.
<b>B56011</b>	60	3	3600	1-1/4"	7.56"	L06119
<b>B56011S</b>	60	3	3600	1-1/4"	7.56"	H05489

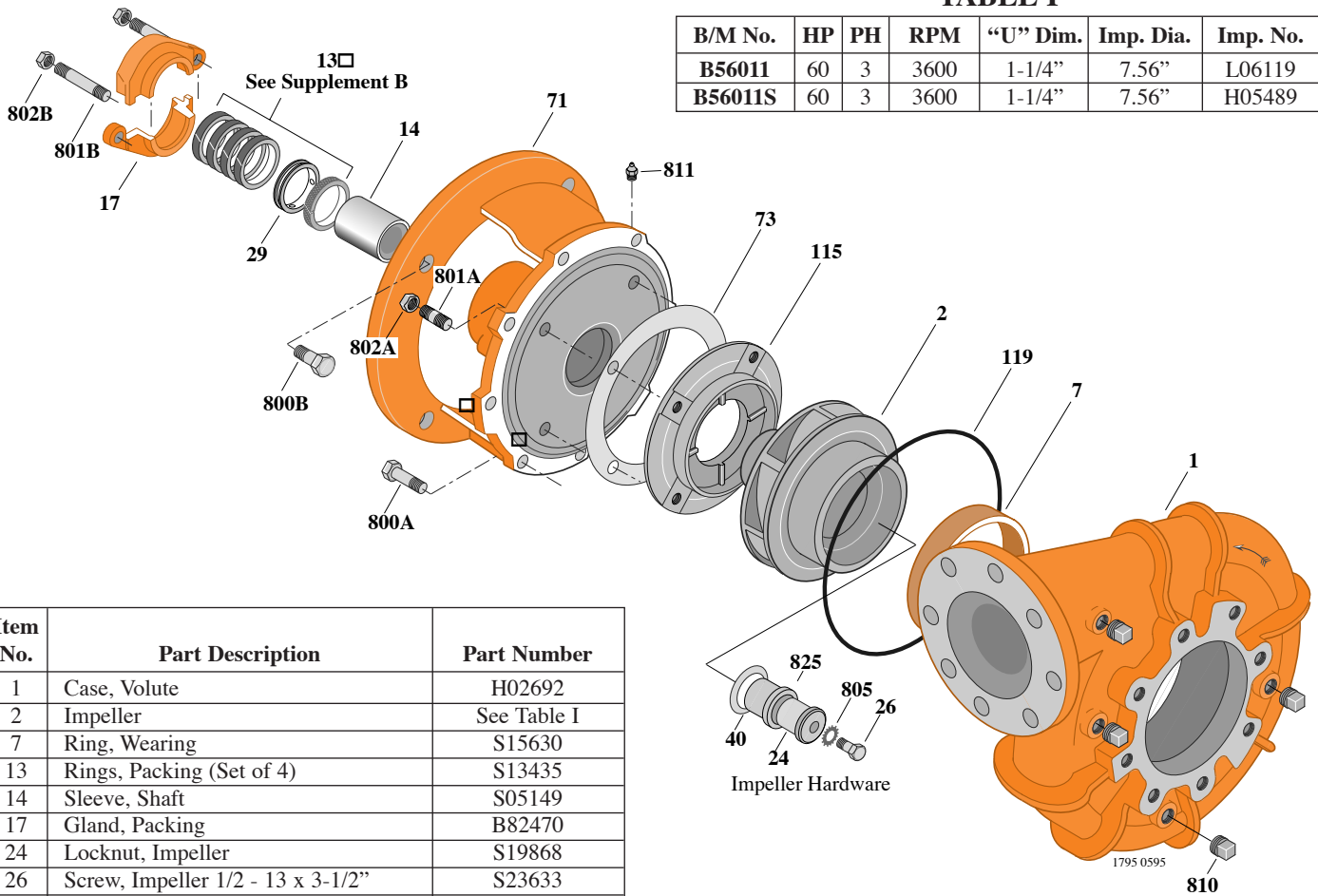

Item No.	Part Description	Part Number
1	Case, Volute	H02692
2	Impeller	See Table I
7	Ring, Wearing	S15630
13	Rings, Packing (Set of 4)	S13435
14	Sleeve, Shaft	S05149
17	Gland, Packing	B82470
24	Locknut, Impeller	S19868
26	Screw, Impeller 1/2 - 13 x 3-1/2"	S23633
29	Ring, Lantern	S19200
32	Key, 1/4 x 2-1/4" (See Note)	S23677
40	Deflector	S19864
71	Bracket	See Table II
73	Gasket, Balance Ring	S09943
115	Ring, Balance	S12334
119	O-Ring	S13760
800A	Capscrew, 1/2 - 13 x 1-1/4" (8 Req.)	S26914
800B	Capscrew, 5/8 - 11 x 1-1/2" (4 Req.)	S26999
801A	Stud, 3/8 - 16 x 1-1/4" (4 Req.)	S23994
801B	Stud, 3/8 - 16 x 2-1/2" (2 Req.)	S04438
802A	Nut, Hex 3/8 - 16 (4 Req.)	S23013
802B	Nut, Hex 3/8 - 16 (2 Req.)	S23343
805	Washer, Lock	S23038
810	Plug, Pipe 1/2 NPT (4 Req.)	S23717
811	Fitting, Grease	S23700
812	Elbow, Street	S25421
825	Sleeve, Impeller Locknut	S19865

**TABLE II**

HP	PH	Bracket No.	"AK" Fit	"U" Dim.	Motor Frame
60	3	L03497	12-1/2"	1-1/4"	326JP

**NOTE:** For an explanation of the tabulated material found on this page and for impeller key location, refer to *Supplement A* located at the beginning of this section.



# TYPE "B" SINGLE STAGE CENTRIFUGAL PUMP Electric Motor Drive

Section	CC
Page	320.2
Date	January 1, 2004
Supersedes 6/1/95	

## BRONZE IMPELLER

## B5EPBM

### Flanged Case

### Packing Construction

**TABLE I**

B/M No.	HP	PH	RPM	"U" Dim.	Imp. Dia.	Imp. No.
B55984	75	3	3600	1-5/8"	8.06"	L06120
B55984S	75	3	3600	1-5/8"	8.06"	H05490
B55985	100	3	3600	1-5/8"	8.01"	L06121
B55985S	100	3	3600	1-5/8"	8.01"	H05491

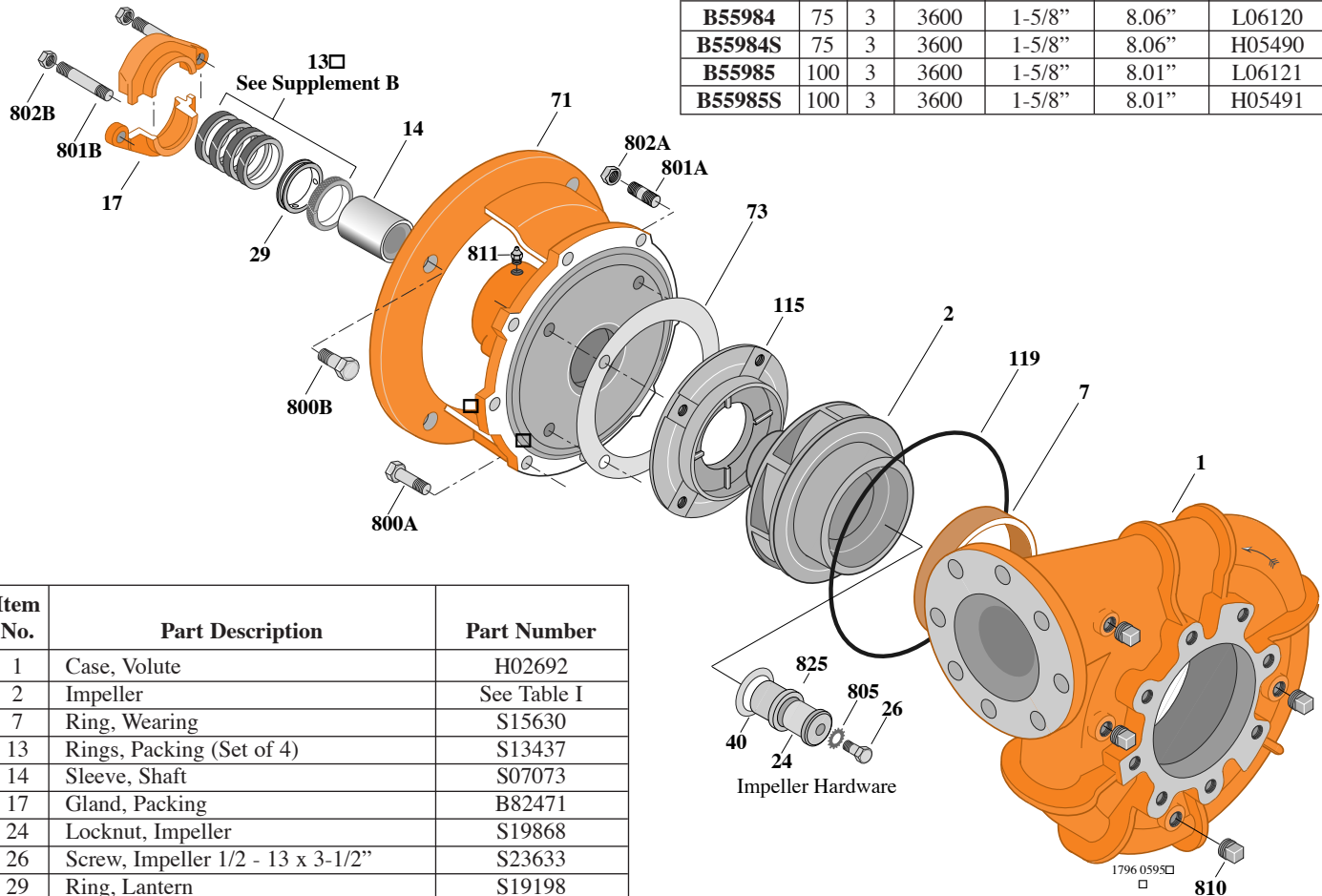

Item No.	Part Description	Part Number
1	Case, Volute	H02692
2	Impeller	See Table I
7	Ring, Wearing	S15630
13	Rings, Packing (Set of 4)	S13437
14	Sleeve, Shaft	S07073
17	Gland, Packing	B82471
24	Locknut, Impeller	S19868
26	Screw, Impeller 1/2 - 13 x 3-1/2"	S23633
29	Ring, Lantern	S19198
32	Key, 3/8 x 2-1/4" (See Note)	S23677
40	Deflector	S19864
71	Bracket	See Table II
73	Gasket, Balance Ring	S09943
115	Ring, Balance	S12334
119	O-Ring	S13760
800A	Capscrew, 1/2 - 13 x 1-1/4" (8 Req.)	S26914
800B	Capscrew, 5/8 - 11 x 1-1/2" (4 Req.)	S26999
801A	Stud, 3/8 - 16 x 1-1/2" (4 Req.)	S23995
801B	Stud, 3/8 - 16 x 2-1/2" (2 Req.)	S04438
802A	Nut, Hex 3/8 - 16 (4 Req.)	S23013
802B	Nut, Hex 3/8 - 16 (2 Req.)	S23343
805	Washer, Lock	S23038
810	Plug, Pipe 1/2 NPT (4 Req.)	S23717
811	Fitting, Grease	S23700
825	Sleeve, Impeller Locknut	S19865

**TABLE II**

HP	PH	Bracket No.	"AK" Fit	"U" Dim.	Motor Frame
75	3	L05610	12-1/2"	1-5/8"	364JP
100	3	L05610	12-1/2"	1-5/8"	365JP

**NOTE:** For an explanation of the tabulated material found on this page and for impeller key location, refer to *Supplement A* located at the beginning of this section.



# TYPE "B" SINGLE STAGE CENTRIFUGAL PUMP Electric Motor Drive

Section	CC
Page	320.3
Date	January 1, 2004
Supersedes 6/1/95	

## BRONZE IMPELLER

## B5EPBM

### Flanged Case

### Packing Construction

**TABLE I**

B/M No.	HP	PH	RPM	"U" Dim.	Imp. Dia.	Imp. No.
<b>B55986</b>	125	3	3600	1-5/8"	9.38"	L06122
<b>B55986S</b>	125	3	3600	1-5/8"	9.38"	H05492
<b>B55987</b>	150	3	3600	1-5/8"	9.88"	L06123
<b>B55987S</b>	150	3	3600	1-5/8"	9.88"	H05493

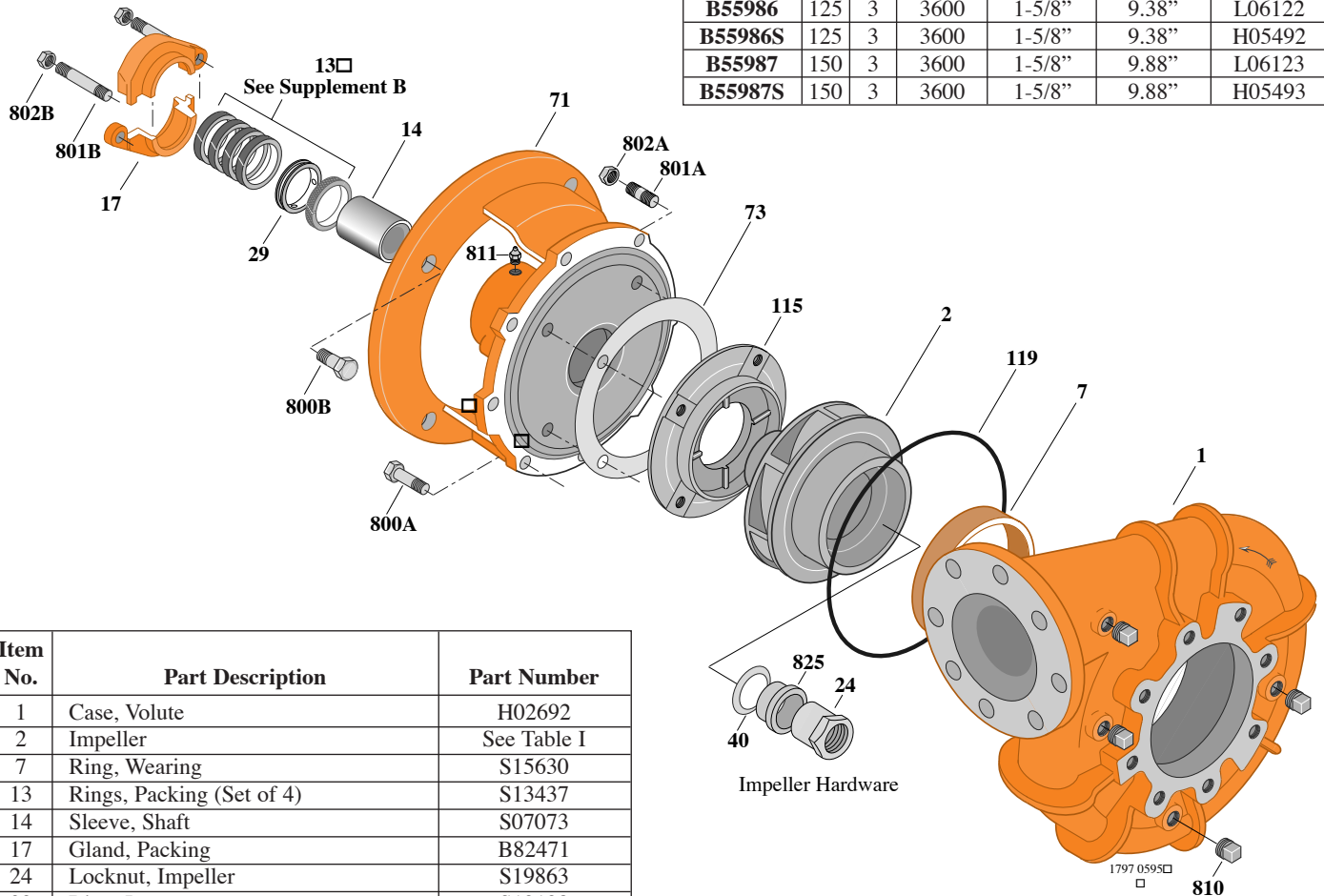

Item No.	Part Description	Part Number
1	Case, Volute	H02692
2	Impeller	See Table I
7	Ring, Wearing	S15630
13	Rings, Packing (Set of 4)	S13437
14	Sleeve, Shaft	S07073
17	Gland, Packing	B82471
24	Locknut, Impeller	S19863
29	Ring, Lantern	S19198
32	Key, 3/8 x 2-1/4" (See Note)	S23940
40	Deflector	S19864
71	Bracket	See Table II
73	Gasket, Balance Ring	S09943
115	Ring, Balance	S12334
119	O-Ring	S13760
800A	Capscrew, 1/2 - 13 x 1-1/4" (8 Req.)	S26914
800B	Capscrew, 5/8 - 11 x 1-1/2" (4 Req.)	S26999
801A	Stud, 3/8 - 16 x 1-1/2" (4 Req.)	S23995
801B	Stud, 3/8 - 16 x 2-1/2" (2 Req.)	S04438
802A	Nut, Hex 3/8 - 16 (4 Req.)	S23103
802B	Nut, Hex 3/8 - 16 (2 Req.)	S23343
810	Plug, Pipe 1/2 NPT (4 Req.)	S23717
811	Fitting, Grease	S23700
825	Sleeve, Impeller Locknut	S19865

**TABLE II**

HP	PH	Bracket No.	"AK" Fit	"U" Dim.	Motor Frame
125	3	L05610	12-1/2"	1-5/8"	404TC
150	3	L05610	12-1/2"	1-5/8"	405TC

**NOTE:** For an explanation of the tabulated material found on this page and for impeller key location, refer to *Supplement A* located at the beginning of this section.



# TYPE "B" SINGLE STAGE CENTRIFUGAL PUMP Electric Motor Drive

Section	CC
Page	320.4
Date	January 1, 2004
Supersedes 6/1/95	

## BRONZE IMPELLER

## B5EPBMS

### Flanged Case

### Mechanical Shaft Seal Construction

**TABLE I**

B/M No.	HP	PH	RPM	"U" Dim.	Imp. Dia.	Imp. No.
B56016	60	3	3600	1-1/4"	7.56"	L06119
B56016S	60	3	3600	1-1/4"	7.56"	H05489

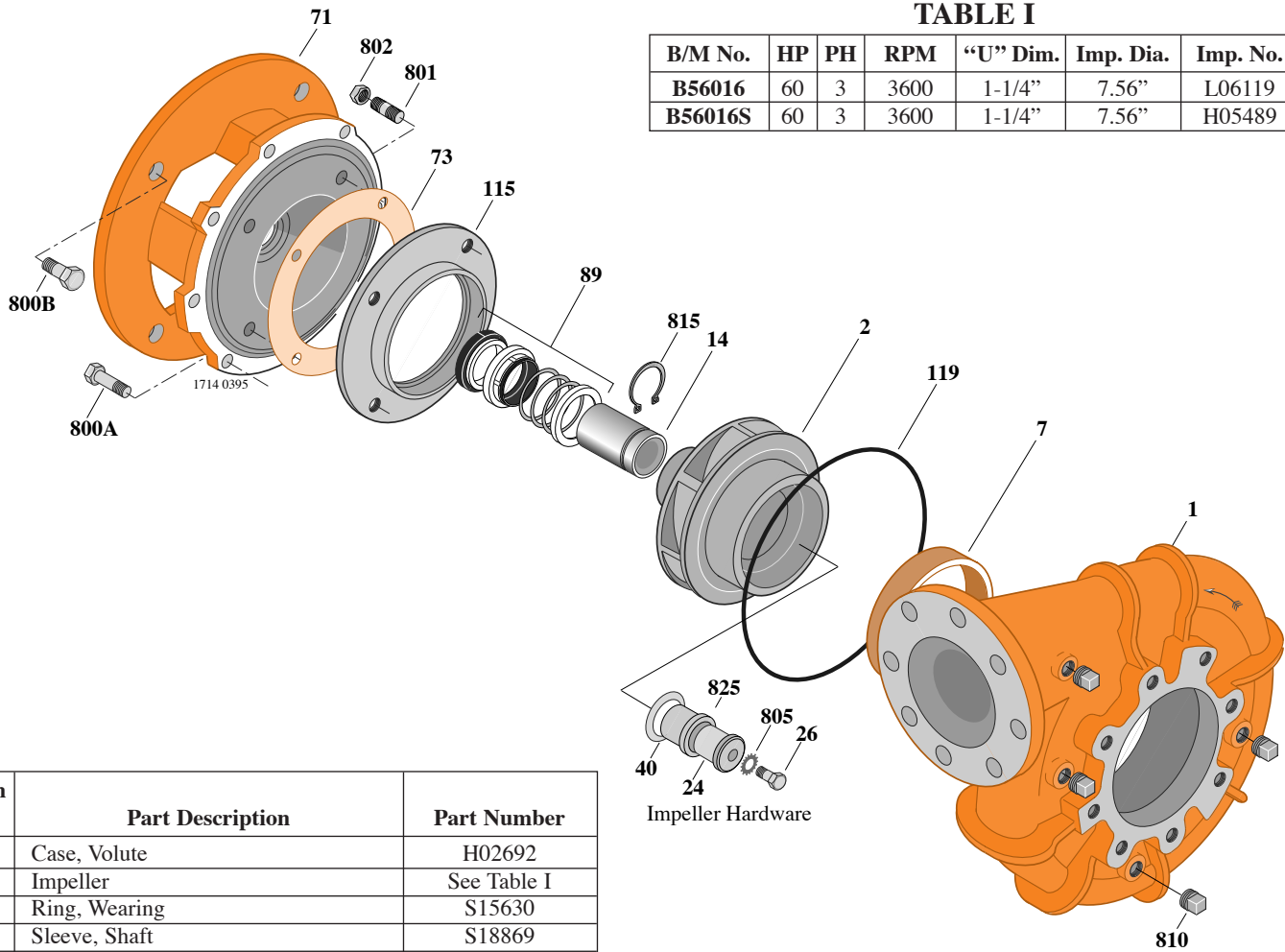

Item No.	Part Description	Part Number
1	Case, Volute	H02692
2	Impeller	See Table I
7	Ring, Wearing	S15630
14	Sleeve, Shaft	S18869
24	Locknut, Impeller	S19868
26	Screw, Impeller 1/2 - 13 x 3-1/2"	S23633
32	Key, 1/4 x 2-1/4" (See Note)	S23677
40	Deflector	S19864
71	Bracket	See Table II
73	Gasket, Balance Ring	S09943
89	Seal, Mechanical Shaft	S32015
115	Ring, Balance	S19109
119	O-Ring	S13760
800A	Capscrew, 1/2 - 13 x 1-1/4" (8 Req.)	S26914
800B	Capscrew, 5/8 - 11 x 1-1/2" (4 Req.)	S26999
801	Stud, 3/8 - 16 x 1-1/2" (4 Req.)	S23995
802	Nut, 3/8 - 16 (4 Req.)	S23103
805	Washer, Lock	S23038
810	Plug, Pipe 1/2 NPT (4 Req.)	S23717
815	Ring, Retaining	S16767
825	Sleeve, Impeller	S19865

**TABLE II**

HP	PH	Bracket No.	"AK" Fit	"U" Dim.	Motor Frame
60	3	L04628	12-1/2"	1-1/4"	326JM

**NOTE:** For an explanation of the tabulated material found on this page and for impeller key location, refer to *Supplement A* located at the beginning of this section.



# Type "B" Single Stage Centrifugal Pump Electric Motor Drive

Section	CC
Page	320.5
Date	July 1, 2011
Supersedes 1/1/04	

## BRONZE IMPELLERB5EPBMS

### Flanged Case

### Mechanical Shaft Seal Construction

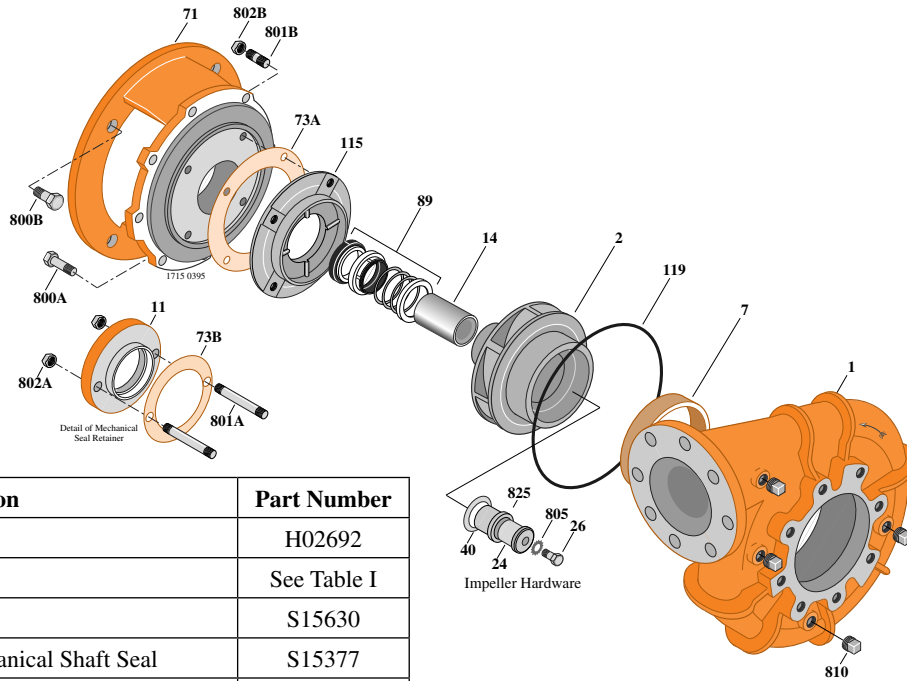

Item	Part Description	Part Number
1	Case, Volute	H02692
2	Impeller	See Table I
7	Ring, Wearing	S15630
11	Retainer, Mechanical Shaft Seal	S15377
14	Sleeve, Shaft	S07073L
24	Locknut, Impeller	S19868
26	Screw, Impeller 1/2-13x3-1/2"	S23633
32	Key, 3/8-2-1/4" (See Note)	S23940
40	Deflector	S19864
71	Bracket	See Table II
73A	Gasket, Balance Ring	S09943
73B	Gasket, Seal Retainer	S15078
89	Seal, Mechanical Shaft	S32016
115	Ring, Balance	S12334
119	O-Ring	S13760
800A	Capscrew, 1/2-13x1-1/4" (8 Req.)	S26914
800B	Capscrew, 5/8-11x1-3/4" (4 Req.)	S27001
801A	Stud, 3/8-16x2-1/2" (2 Req.)	S04438
801B	Stud, 3/8-16x1-1/2" (4 Req.)	S23994
802A	Nut, Hex 3/8-16 (2 Req.)	S23343
802B	Nut, Hex 3/8-16 (4 Req.)	S23103
805	Washer, Lock	S23038
810	Plug, Pipe 1/2 NPT (4 Req.)	S23717
820	Connector, Comp. Fitting (2 Req.)	S23013
822	Tubing, Copper	S20677
825	Sleeve, Impeller Locknut	S19865
•	Plug, Pipe 1/8 NPT (Not Illustrated)	S23714

**Table I**

B/M No.	HP	PH	RPM	"U" Dim.	Imp. Dia.	Imp. No.
B62093	75	3	3600	1-5/8"	8.06"	L06120
B62093S	75	3	3600	1-5/8"	8.06"	H05490
B62094	100	3	3600	1-5/8"	8.81"	L06121
B62094S	100	3	3600	1-5/8"	8.81"	H05491

**Table II**

HP	PH	Bracket No.	"AK" Fit	"U" Dim.	Motor Frame
75	3	L06315	12-1/2"	1-5/8"	364JP
100	3	L06315	12-1/2"	1-5/8"	365JP

**NOTE:** For an explanation of the tabulated material found on this page and for impeller key location, refer to *Supplement A* located at the beginning of this section.



# Type "B" Single Stage Centrifugal Pump Electric Motor Drive

Section	CC
Page	320.6
Date	July 1, 2011
Supersedes 1/1/04	

## BRONZE IMPELLERB5EPBMS

### Flanged Case

### Mechanical Shaft Seal Construction

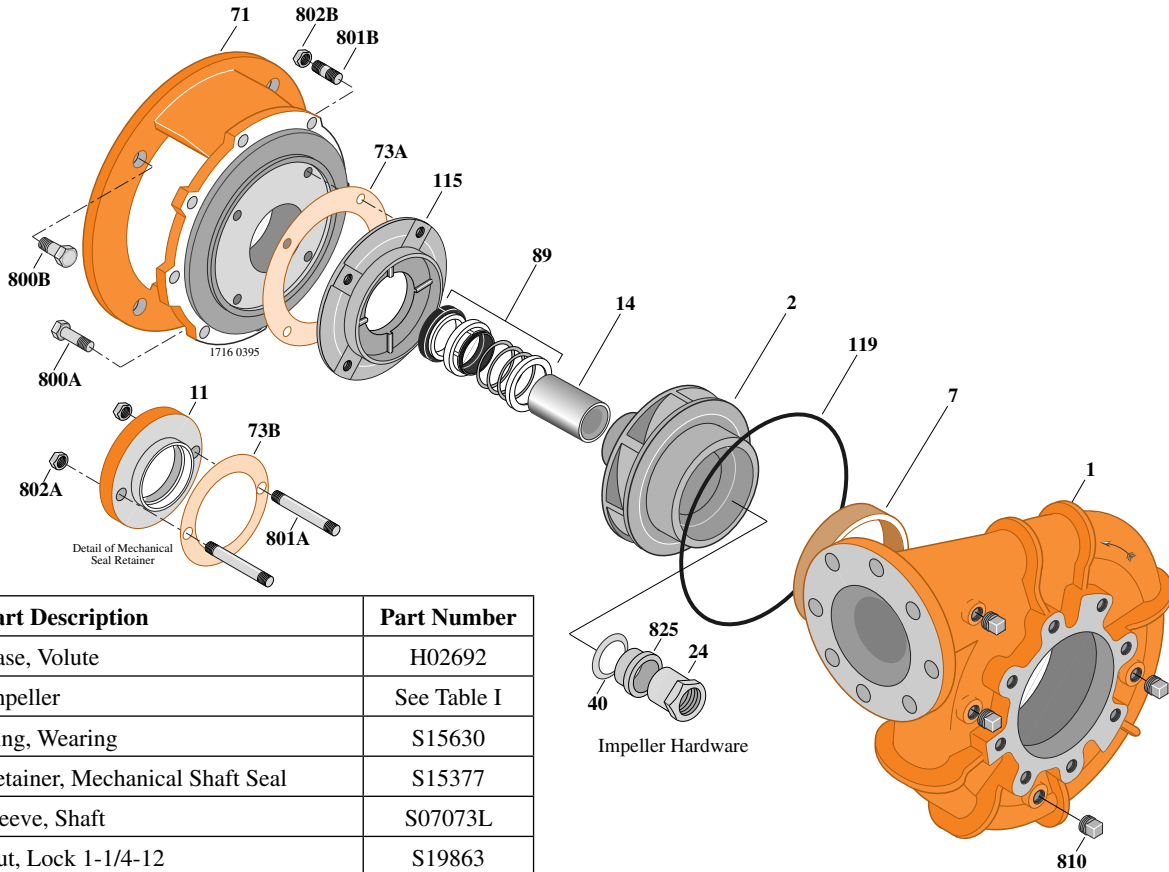

Item	Part Description	Part Number
1	Case, Volute	H02692
2	Impeller	See Table I
7	Ring, Wearing	S15630
11	Retainer, Mechanical Shaft Seal	S15377
14	Sleeve, Shaft	S07073L
24	Nut, Lock 1-1/4-12	S19863
32	Key, 3/8x2-1/4" (See Note)	S23940
40	Deflector	S19864
71	Bracket	See Table II
73A	Gasket, Balance Ring	S09943
89	Seal, Mechanical Shaft	S32016
115	Ring, Balance	S12334
119	O-Ring	S13760
800A	Capscrew, 1/2-13x1-1/4" (8 Req.)	S26914
800B	Capscrew, 5/8-11x1-3/4" (4 Req.)	S27001
801A	Stud, 3/8-16x2-1/2" (2 Req.)	S04438
801B	Stud, 3/8-16x1-1/4" (4 Req.)	S23994
802A	Nut, Hex 3/8-16 (2 Req.)	S23343
802B	Nut, Hex 3/8-16 (4 Req.)	S23103
810	Plug, Pipe 1/2 NPT (4 Req.)	S23717
820	Connector, Comp. Fitting (2 Req.)	S24013
822	Tubing, Copper	S20677
825	Sleeve, Impeller Locknut	S19865
•	Plug, Pipe 1/8 NPT (Not Illustrated)	S23714

**Table I**

B/M No.	HP	PH	RPM	"U" Dim.	Imp. Dia.	Imp. No.
B62095	125	3	3600	1-5/8"	9.38"	L06122
B62095S	125	3	3600	1-5/8"	9.38"	H05492
B62096	150	3	3600	1-5/8"	9.88"	L06123
B62096S	150	3	3600	1-5/8"	9.88"	H05493

**Table II**

HP	PH	Bracket No.	"AK" Fit	"U" Dim.	Motor Frame
125	3	L06315	12-1/2"	1-5/8"	404TC
150	3	L06315	12-1/2"	1-5/8"	405TC

**NOTE 1:** For an explanation of the tabulated material found on this page and for impeller key location, refer to *Supplement A* located at the beginning of this section.



# TYPE "B" SINGLE STAGE CENTRIFUGAL PUMP Electric Motor Drive

Section	CC
Page	320.7
Date	September 1, 1997
Supersedes/New	

## SILICON BRONZE IMPELLER

## B5EPBM

### Flanged Case

### Packing Construction

TABLE I

B/M No.	HP	PH	RPM	"U" Dim.	Imp. Dia.	Imp. No.
B56011S	60	3	3600	1-1/4"	7.56"	H05489

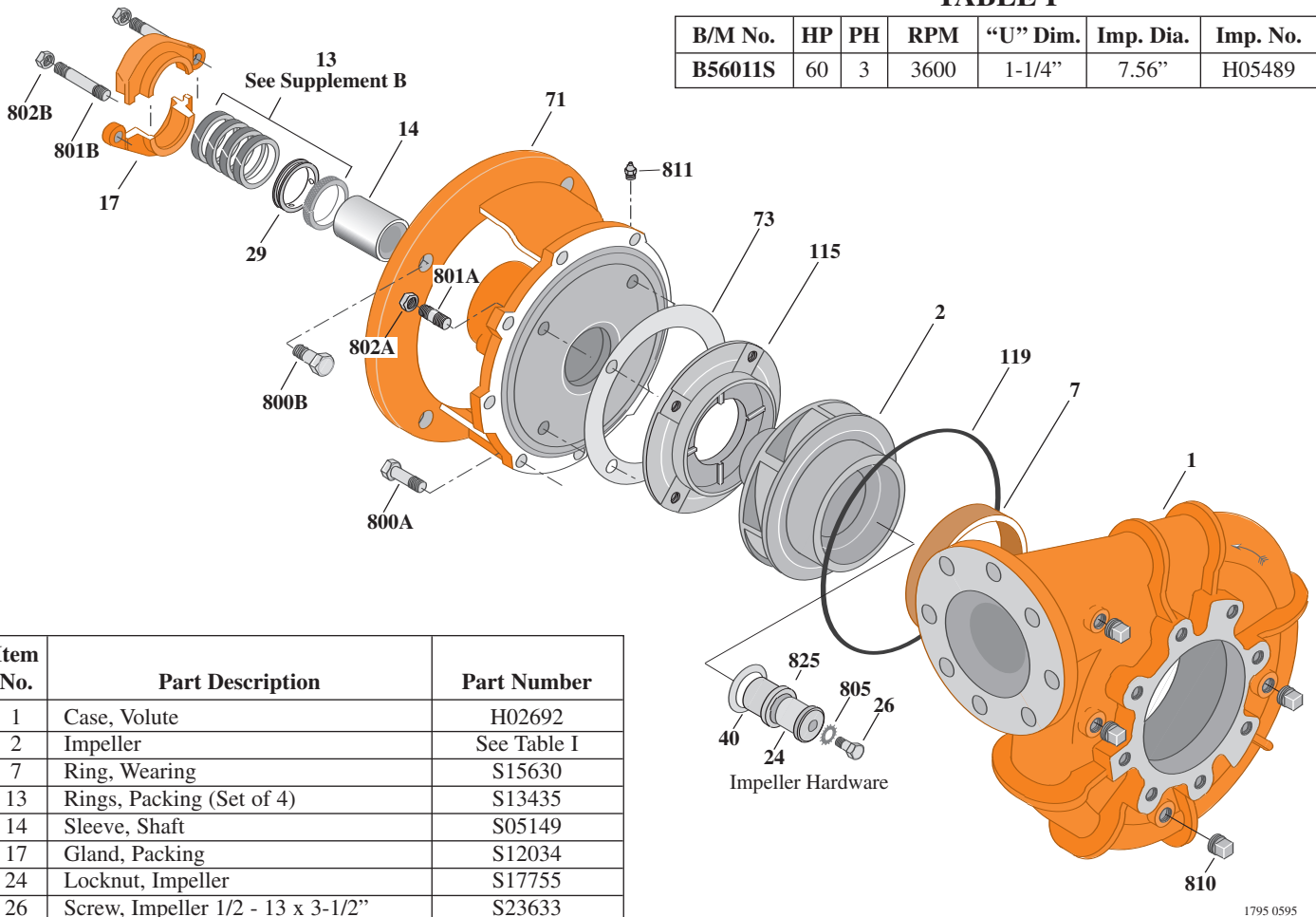

1795 0595

Item No.	Part Description	Part Number
1	Case, Volute	H02692
2	Impeller	See Table I
7	Ring, Wearing	S15630
13	Rings, Packing (Set of 4)	S13435
14	Sleeve, Shaft	S05149
17	Gland, Packing	S12034
24	Locknut, Impeller	S17755
26	Screw, Impeller 1/2 - 13 x 3-1/2"	S23633
29	Ring, Lantern	S19200
32	Key, 1/4 x 2-1/4" (See Note)	S23677
40	Deflector	S19864
71	Bracket	See Table II
73	Gasket, Balance Ring	S09943
115	Ring, Balance	S12334
119	O-Ring	S13760
800A	Capscrew, 1/2 - 13 x 1-1/4" (8 Req.)	S26914
800B	Capscrew, 5/8 - 11 x 1-1/2" (4 Req.)	S26999
801A	Stud, 3/8 - 16 x 1-1/4" (4 Req.)	S23994
801B	Stud, 3/8 - 16 x 2-1/2" (2 Req.)	S04438
802A	Nut, Hex 3/8 - 16 (4 Req.)	S23013
802B	Nut, Hex 3/8 - 16 (2 Req.)	S23343
805	Washer, Lock	S23038
810	Plug, Pipe 1/2" NPT (4 Req.)	S23717
811	Fitting, Grease	S23700
825	Sleeve, Impeller Locknut	S19865

TABLE II

HP	PH	Bracket No.	"AK" Fit	"U" Dim.	Motor Frame
60	3	L03497	12-1/2"	1-1/4"	326JP

**NOTE:** For an explanation of the tabulated material found on this page and for impeller key location, refer to *Supplement A* located at the beginning of this section.



# TYPE "B" SINGLE STAGE CENTRIFUGAL PUMP Electric Motor Drive

Section	CC
Page	320.8
Date	September 1, 1997
Supersedes/New	

## SILICON BRONZE IMPELLER

## B5EPBM

### Flanged Case

### Packing Construction

**TABLE I**

B/M No.	HP	PH	RPM	"U" Dim.	Imp. Dia.	Imp. No.
<b>B55984S</b>	75	3	3600	1-5/8"	8.06"	H05490
<b>B55985S</b>	100	3	3600	1-5/8"	8.01"	H05491

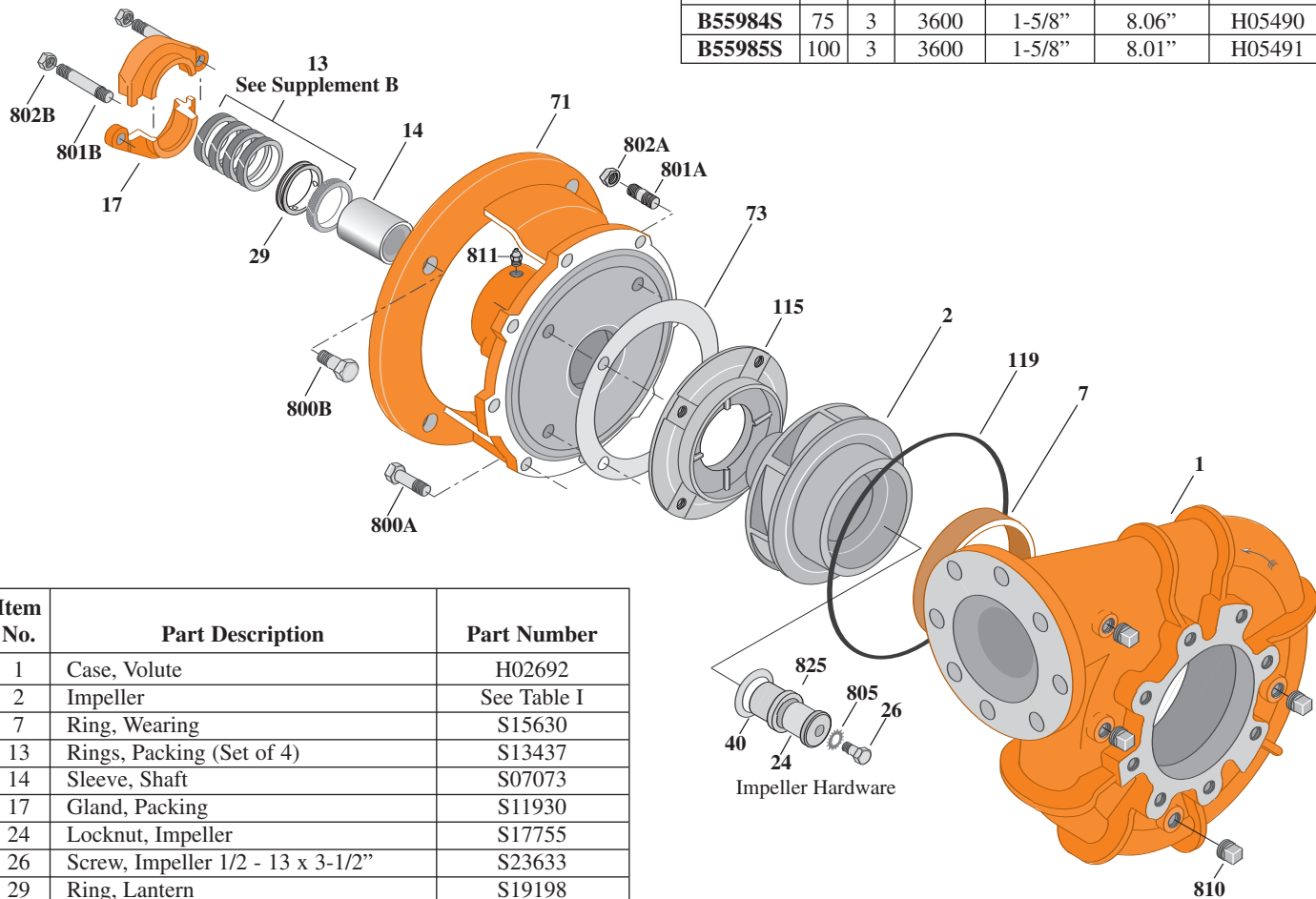

Item No.	Part Description	Part Number
1	Case, Volute	H02692
2	Impeller	See Table I
7	Ring, Wearing	S15630
13	Rings, Packing (Set of 4)	S13437
14	Sleeve, Shaft	S07073
17	Gland, Packing	S11930
24	Locknut, Impeller	S17755
26	Screw, Impeller 1/2 - 13 x 3-1/2"	S23633
29	Ring, Lantern	S19198
32	Key, 3/8 x 2" (See Note)	S23939
40	Deflector	S19864
71	Bracket	See Table II
73	Gasket, Balance Ring	S09943
115	Ring, Balance	S12334
119	O-Ring	S13760
800A	Capscrew, 1/2 - 13 x 1-1/4" (8 Req.)	S26914
800B	Capscrew, 5/8 - 11 x 1-1/2" (4 Req.)	S26999
801A	Stud, 3/8 - 16 x 1-1/2" (4 Req.)	S23995
801B	Stud, 3/8 - 16 x 2-1/2" (2 Req.)	S04438
802A	Nut, Hex 3/8 - 16 (4 Req.)	S23013
802B	Nut, Hex 3/8 - 16 (2 Req.)	S23343
805	Washer, Lock	S23038
810	Plug, Pipe 1/2" NPT (4 Req.)	S23717
811	Fitting, Grease	S23700
825	Sleeve, Impeller Locknut	S19865

**TABLE II**

HP	PH	Bracket No.	"AK" Fit	"U" Dim.	Motor Frame
75	3	L05610	12-1/2"	1-5/8"	364JP
100	3	L05610	12-1/2"	1-5/8"	365JP

**NOTE:** For an explanation of the tabulated material found on this page and for impeller key location, refer to *Supplement A* located at the beginning of this section.





# TYPE "B" SINGLE STAGE CENTRIFUGAL PUMP Electric Motor Drive

Section	CC
Page	320.9
Date	September 1, 1997
Supersedes/New	

## SILICON BRONZE IMPELLER

## B5EPBM

### Flanged Case

### Packing Construction

**TABLE I**

B/M No.	HP	PH	RPM	"U" Dim.	Imp. Dia.	Imp. No.
B55986S	125	3	3600	1-5/8"	9.38"	H05492
B55987S	150	3	3600	1-5/8"	9.88"	H05493

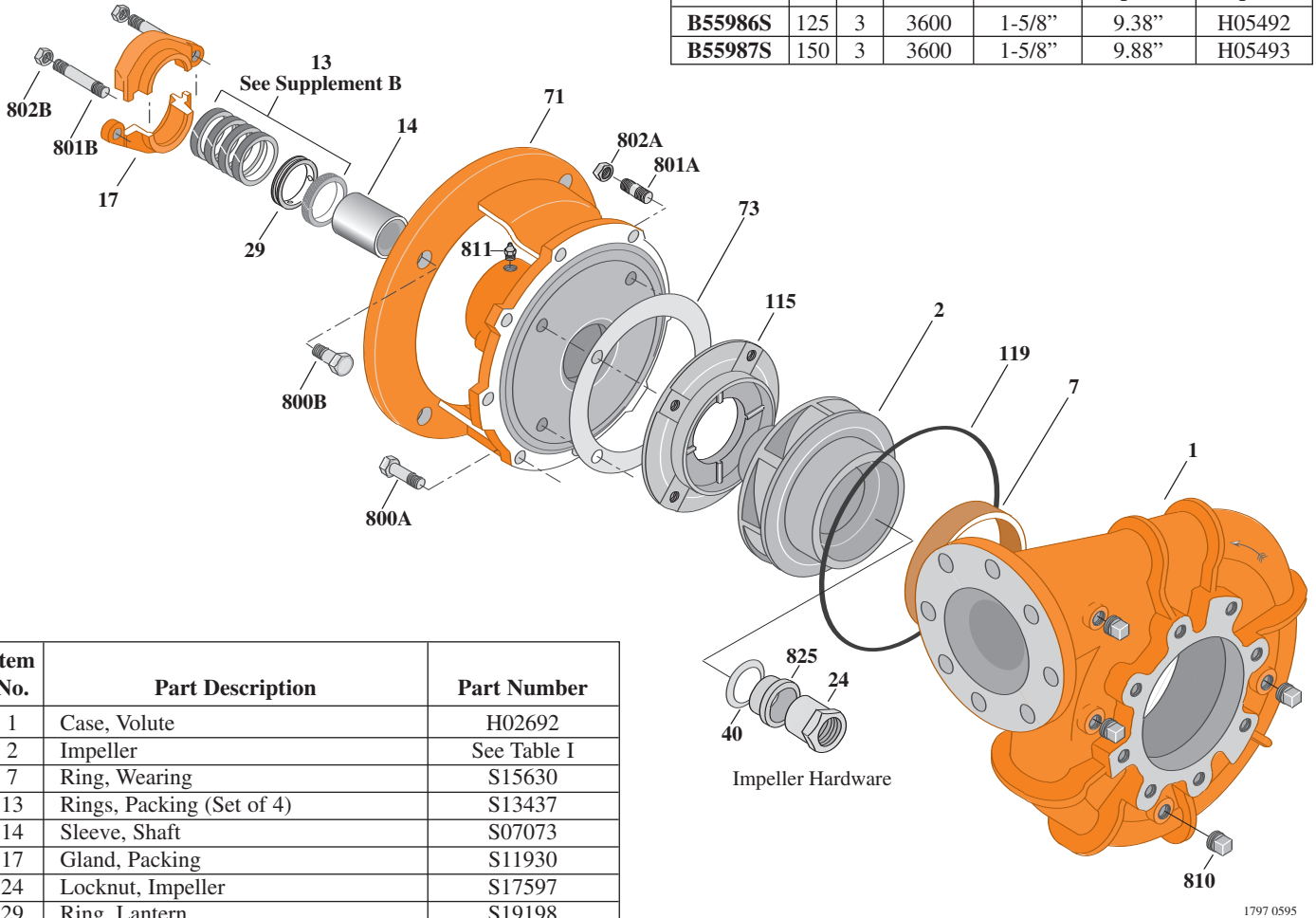

Item No.	Part Description	Part Number
1	Case, Volute	H02692
2	Impeller	See Table I
7	Ring, Wearing	S15630
13	Rings, Packing (Set of 4)	S13437
14	Sleeve, Shaft	S07073
17	Gland, Packing	S11930
24	Locknut, Impeller	S17597
29	Ring, Lantern	S19198
32	Key, 3/8 x 2-1/4" (See Note)	S23940
40	Deflector	S19864
71	Bracket	See Table II
73	Gasket, Balance Ring	S09943
115	Ring, Balance	S12334
119	O-Ring	S13760
800A	Capscrew, 1/2 - 13 x 1-1/4" (8 Req.)	S26914
800B	Capscrew, 5/8 - 11 x 1-1/2" (4 Req.)	S26999
801A	Stud, 3/8 - 16 x 1-1/2" (4 Req.)	S23995
801B	Stud, 3/8 - 16 x 2-1/2" (2 Req.)	S04438
802A	Nut, Hex 3/8 - 16 (4 Req.)	S23103
802B	Nut, Hex 3/8 - 16 (2 Req.)	S23343
810	Plug, Pipe 1/2" NPT (4 Req.)	S23717
811	Fitting, Grease	S23700
825	Sleeve, Impeller Locknut	S19865

**TABLE II**

HP	PH	Bracket No.	"AK" Fit	"U" Dim.	Motor Frame
125	3	L05610	12-1/2"	1-5/8"	404TC
150	3	L05610	12-1/2"	1-5/8"	405TC

**NOTE:** For an explanation of the tabulated material found on this page and for impeller key location, refer to *Supplement A* located at the beginning of this section.



# TYPE "B" SINGLE STAGE CENTRIFUGAL PUMP Electric Motor Drive

Section	CC
Page	320.11
Date	September 1, 1997
Supersedes/New	

## SILICON BRONZE IMPELLER

## B5EPBMS

### Flanged Case

### Mechanical Shaft Seal Construction

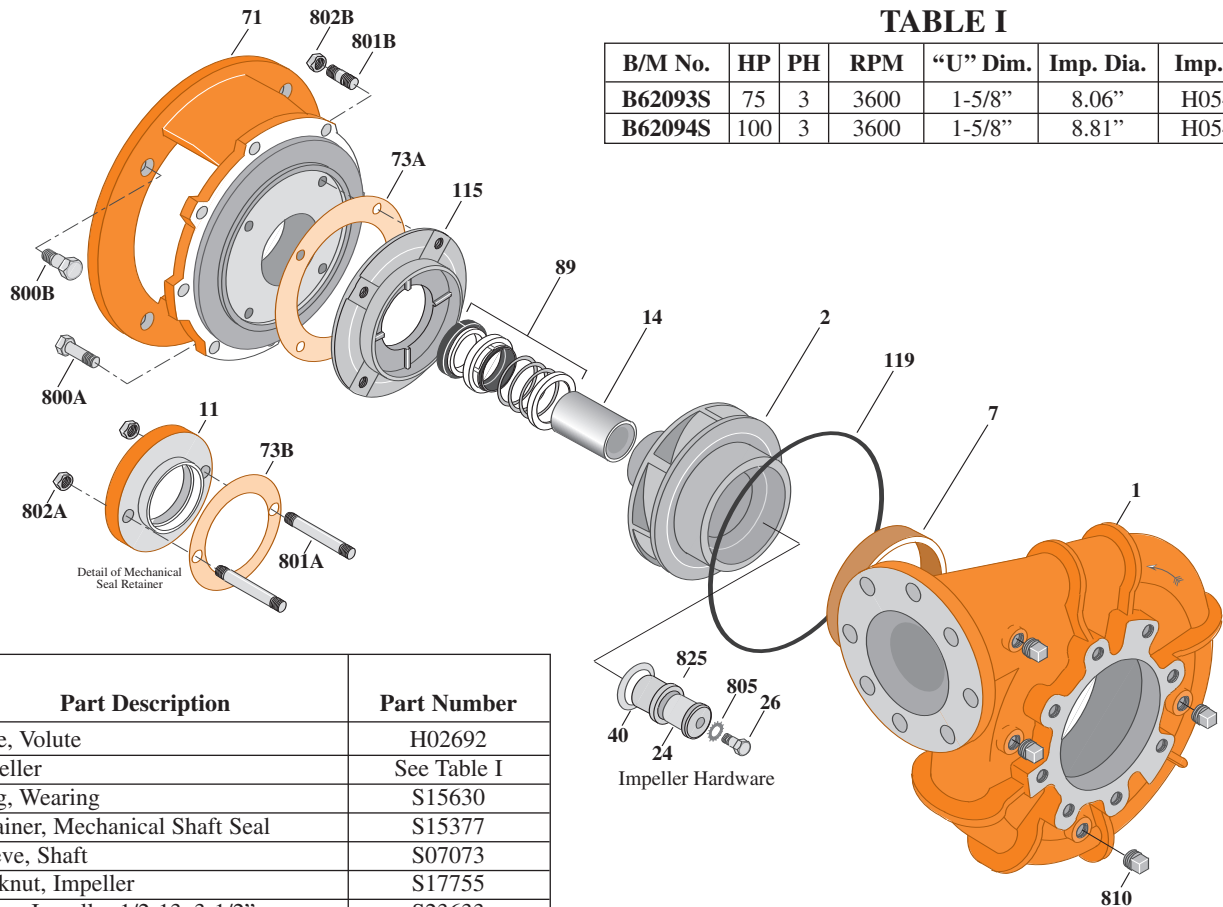

TABLE I

B/M No.	HP	PH	RPM	"U" Dim.	Imp. Dia.	Imp. No.
B62093S	75	3	3600	1-5/8"	8.06"	H05490
B62094S	100	3	3600	1-5/8"	8.81"	H05491

Item No.	Part Description	Part Number
1	Case, Volute	H02692
2	Impeller	See Table I
7	Ring, Wearing	S15630
11	Retainer, Mechanical Shaft Seal	S15377
14	Sleeve, Shaft	S07073
24	Locknut, Impeller	S17755
26	Screw, Impeller 1/2-13x3-1/2"	S23633
32	Key, 3/8-2" (See Note)	S23939
40	Deflector	S19864
71	Bracket	See Table II
73A	Gasket, Balance Ring	S09943
73B	Gasket, Seal Retainer	S15078
89	Seal, Mechanical Shaft	S32016
115	Ring, Balance	S12334
119	O-Ring	S13760
800A	Capscrew, 1/2-13x1-1/4" (8 Req.)	S26914
800B	Capscrew, 5/8-11x1-3/4" (4 Req.)	S27001
801A	Stud, 3/8-16x2-1/2" (2 Req.)	S04438
801B	Stud, 3/8-16x1-1/2" (4 Req.)	S23995
802A	Nut, Hex 3/8-16 (2 Req.)	S23343
802B	Nut, Hex 3/8-16 (4 Req.)	S23103
805	Washer, Lock	S23038
810	Plug, Pipe 1/2" NPT (4 Req.)	S23717
825	Sleeve, Impeller Locknut	S19865
•	Plug, Pipe 1/8" NPT (In Bracket)	S23714

• Not illustrated.

TABLE II

HP	PH	Bracket No.	"AK" Fit	"U" Dim.	Motor Frame
75	3	L06315	12-1/2"	1-5/8"	364JP
100	3	L06315	12-1/2"	1-5/8"	365JP

**NOTE:** For an explanation of the tabulated material found on this page and for impeller key location, refer to *Supplement A* located at the beginning of this section.

**NOTE:** For seal flush line details, see *Supplement D*.

1715 0395



# TYPE "B" SINGLE STAGE CENTRIFUGAL PUMP Electric Motor Drive

Section	CC
Page	320.12
Date	September 1, 1997
Supersedes/New	

## SILICON BRONZE IMPELLER

## B5EPBMS

### Flanged Case

### Mechanical Shaft Seal Construction

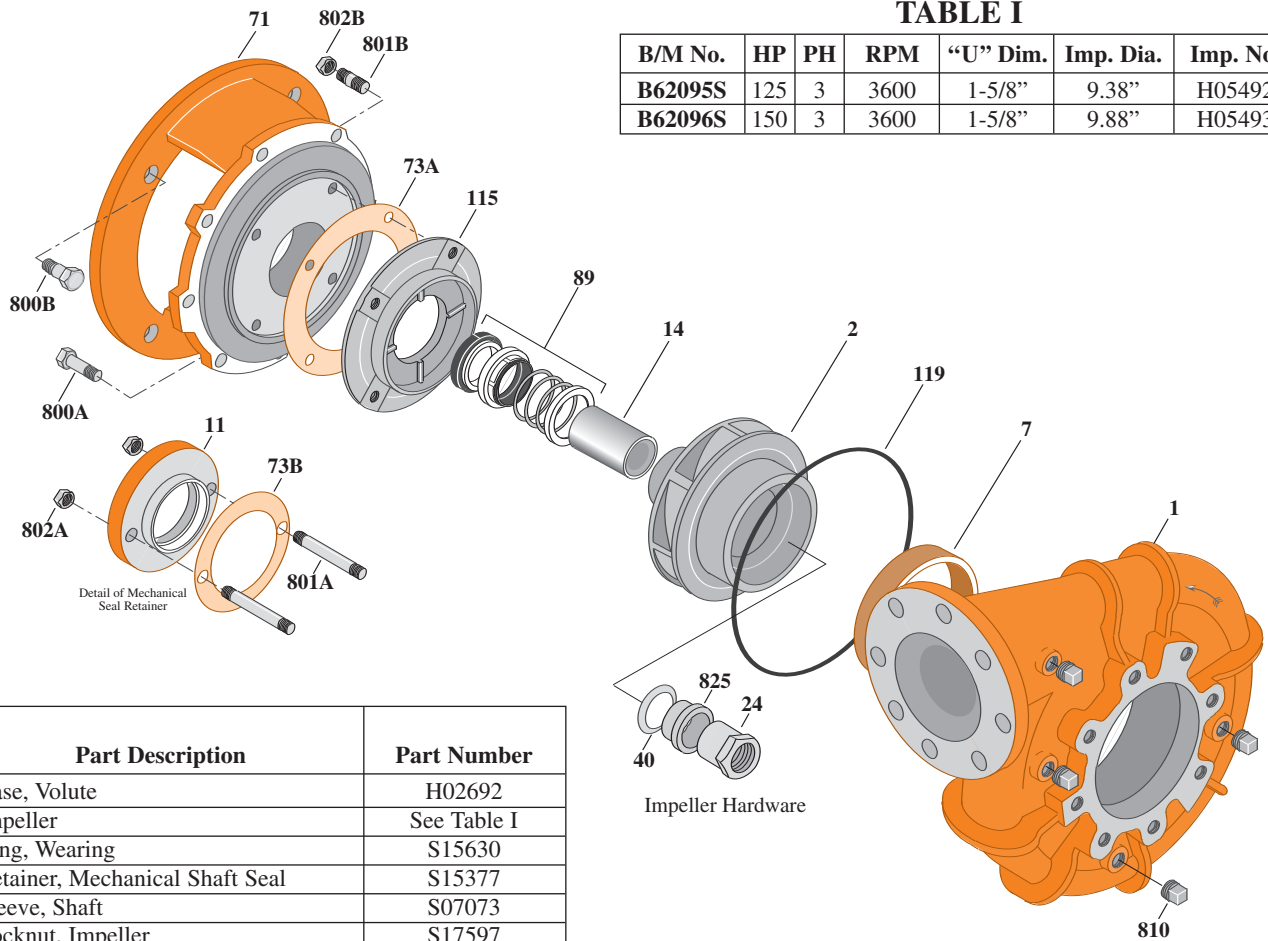

**TABLE I**

B/M No.	HP	PH	RPM	"U" Dim.	Imp. Dia.	Imp. No.
B62095S	125	3	3600	1-5/8"	9.38"	H05492
B62096S	150	3	3600	1-5/8"	9.88"	H05493

Item No.	Part Description	Part Number
1	Case, Volute	H02692
2	Impeller	See Table I
7	Ring, Wearing	S15630
11	Retainer, Mechanical Shaft Seal	S15377
14	Sleeve, Shaft	S07073
24	Locknut, Impeller	S17597
32	Key, 3/8x2-1/4" (See Note)	S23940
40	Deflector	S19864
71	Bracket	See Table II
73A	Gasket, Balance Ring	S09943
73B	Gasket, Seal Retainer	S15078
89	Seal, Mechanical Shaft	S32016
115	Ring, Balance	S12334
119	O-Ring	S13760
800A	Capscrew, 1/2-13x1-1/4" (8 Req.)	S26914
800B	Capscrew, 5/8-11x1-3/4" (4 Req.)	S27001
801A	Stud, 3/8-16x2-1/2" (2 Req.)	S04438
801B	Stud, 3/8-16x1-1/2" (4 Req.)	S23995
802A	Nut, Hex 3/8-16 (2 Req.)	S23343
802B	Nut, Hex 3/8-16 (4 Req.)	S23103
810	Plug, Pipe 1/2" NPT (4 Req.)	S23717
825	Sleeve, Impeller Locknut	S19865
•	Plug, Pipe 1/8" NPT (In Bracket)	S23714

• Not illustrated.

**TABLE II**

HP	PH	Bracket No.	"AK" Fit	"U" Dim.	Motor Frame
125	3	L06315	12-1/2"	1-5/8"	404TC
150	3	L06315	12-1/2"	1-5/8"	405TC

**NOTE:** For an explanation of the tabulated material found on this page and for impeller key location, refer to *Supplement A* located at the beginning of this section.

**NOTE:** For seal flush line details, see *Supplement D*.

1716 0395