



# TYPE "B" SINGLE STAGE CENTRIFUGAL PUMP Electric Motor Drive

Section	CC
Page	270.3
Date	January 1, 2004
Supersedes 6/1/95	

## CAST IRON IMPELLER

## B4JPBHH

### Flanged Case

### Packing Construction

**TABLE I**

B/M No.	HP	PH	RPM	"U" Dim.	Imp. Dia.	Imp. No.
B55974	60	3	1800	1-5/8"	13.50"	L05400

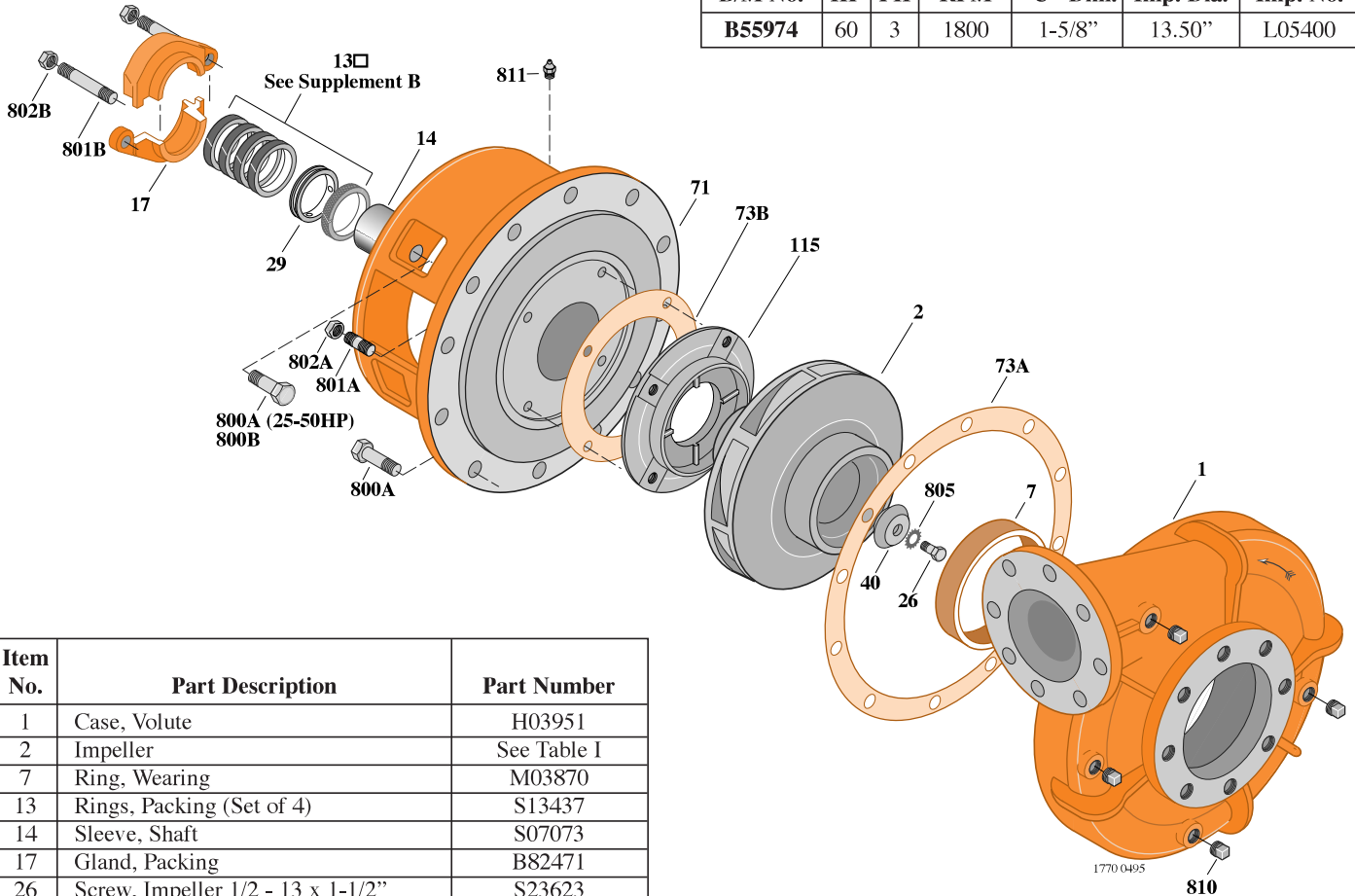

Item No.	Part Description	Part Number
1	Case, Volute	H03951
2	Impeller	See Table I
7	Ring, Wearing	M03870
13	Rings, Packing (Set of 4)	S13437
14	Sleeve, Shaft	S07073
17	Gland, Packing	B82471
26	Screw, Impeller 1/2 - 13 x 1-1/2"	S23623
29	Ring, Lantern	S19198
32	Key, 3/8 x 2-1/4" (See Note)	S23940
40	Deflector	S18801
71	Bracket	See Table II
73A	Gasket, Volute	S06271
73B	Gasket, Balance Ring	S09943
115	Ring, Balance	S19521
800A	Capscrew, 5/8 - 11 x 1-1/2" (12 Req.)	S26999
800B	Capscrew, 5/8 - 11 x 1-3/4" (4 Req.)	S27001
801A	Stud, 3/8 - 16 x 1-3/4" (4 Req.)	S23996
801B	Stud, 3/8 - 16 x 2-1/2" (2 Req.)	S04438
802A	Nut, Hex 3/8 - 16 (4 Req.)	S23103
802B	Nut, Hex 3/8 - 16 (2 Req.)	S23343
805	Washer, Lock	S23038
810	Plug, Pipe 1/2 NPT (4 Req.)	S23717
811	Fitting, Grease	S23700
812	Elbow, Street	S25421

**TABLE II**

HP	PH	Bracket No.	"AK" Fit	"U" Dim.	Motor Frame
60	3	H03622	12-1/2"	1-5/8"	364JP

**NOTE:** For an explanation of the tabulated material found on this page and for impeller key location, refer to *Supplement A* located at the beginning of this section.



# TYPE "B" SINGLE STAGE CENTRIFUGAL PUMP Electric Motor Drive

Section	CC
Page	270.4
Date	January 1, 2004
Supersedes 6/1/95	

## CAST IRON IMPELLER B4JPBHHS

### Flanged Case

### Mechanical Shaft Seal Construction

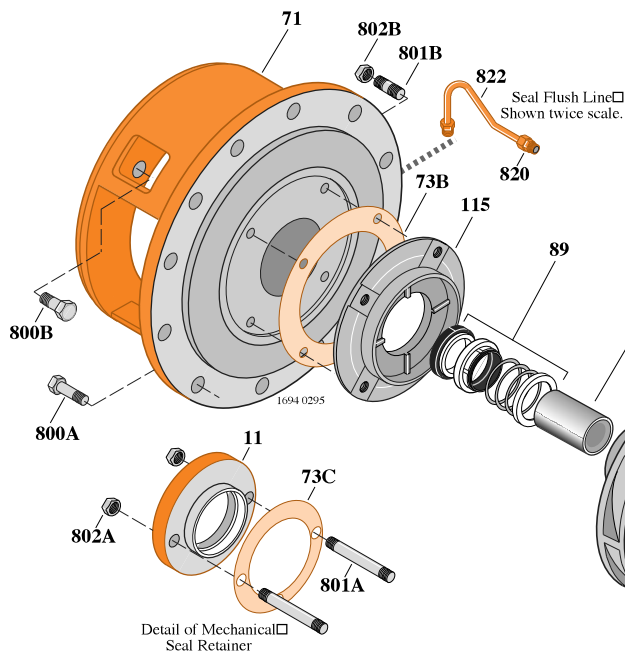

**TABLE I**

B/M No.	HP	PH	RPM	"U" Dim.	Imp. Dia.	Imp. No.
<b>B62036</b>	60	3	1800	1-5/8"	13.50"	L05400

Item No.	Part Description	Part Number
1	Case, Volute	H03951
2	Impeller	See Table I
7	Ring, Wearing	M03870
11	Retainer, Mechanical Shaft Seal	S15377
14	Sleeve, Shaft	S07073
26	Screw, Impeller 1/2 - 13 x 1-1/2"	S23623
32	Key, 3/8 x 2-1/4" (See Note)	S23940
40	Deflector	S18801
71	Bracket	See Table II
73A	Gasket, Volute Case	S06271
73B	Gasket, Balance Ring	S09943
73C	Gasket, Seal Retainer	S15078
89	Seal, Mechanical Shaft	S32016
115	Ring, Balance	S19521
800A	Capscrew, 5/8 - 11 x 1-1/2" (12 Req.)	S26999
800B	Capscrew, 5/8 - 11 x 1-3/4" (4 Req.)	S27001
801A	Stud, 3/8 - 16 x 2-1/2" (2 Req.)	S04438
802A	Nut, 3/8 - 16	S23343
801B	Stud, 3/8 - 16 x 1-3/4" (4 Req.)	S23996
802B	Nut, 3/8 - 16 (4 Req.)	S23013
805	Washer, Lock	S23038
810	Plug, Pipe 1/2 NPT	S23717
820	Connector, Comp. Fitting (2 Req.)	S24013
822	Tubing, Copper	S20677
•	Plug, Pipe 1/8 NPT (Not Illustrated)	S23714

**TABLE II**

HP	PH	Bracket No.	"AK" Fit	"U" Dim.	Motor Frame
60	3	H03936	12-1/2"	1-5/8"	364JP

**NOTE:** For an explanation of the tabulated material found on this page and for impeller key location, refer to *Supplement A* located at the beginning of this section.