



TYPE "B" SINGLE STAGE CENTRIFUGAL PUMP Electric Motor Drive

Section	CC
Page	275.1
Date	January 1, 2004
Supersedes 9/1/97	

SILICON BRONZE IMPELLER

B4GPBH

Flanged Case

Packing Construction

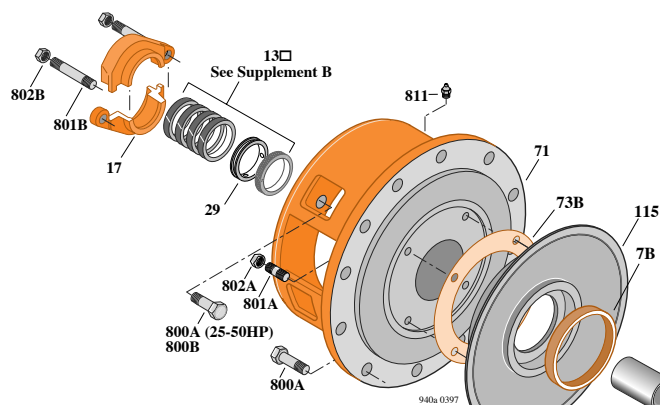

TABLE I

B/M No.	HP	PH	RPM	"U" Dim.	Imp. Dia.	Imp. No.
B75868	15	3	1750	1-1/4"	9.50"	M11268
B75859	20	3	1750	1-1/4"	10.31"	M11267
B75858	25	3	1750	1-1/4"	11.06"	M11266
B75857	30	3	1750	1-1/4"	11.69"	M11265
B75856	40	3	1750	1-1/4"	12.56"	M11264
B75855	50	3	1750	1-1/4"	12.75"	H05779

Item No.	Part Description	Part Number
1	Case, Volute	H05778
2	Impeller	See Table I
7A	Ring, Wearing	M11195
7B	Ring, Wearing	M11194
13	Ring, Packing (Set of 5)	S13435
14	Sleeve, Shaft	S05149
17	Gland, Packing	B82470
26	Screw, Impeller 5/8 - 11 x 1-3/4"	S27001
29	Ring, Lantern	S19200
69	Deflector	S06319
71	Bracket	See Table II
73A	Gasket, Volute Case	S06271
73B	Gasket, Balance Ring	S09943
73C	Gasket, Eccentric Reducer	S10367
115	Ring, Balance	H05781
800A	Capscrew, 5/8 - 11 x 1-1/2" (16 Req.) (12-1/2 AK)	S26999
800A	Capscrew, 5/8 - 11 x 1-1/2" (12 Req.) (8-1/2 AK)	S26999
800B	Capscrew, 1/2 - 13 x 1-1/2" (4 Req.) (8-1/2 AK Only)	S26916
800C	Capscrew, 3/4" - 10 x 1-3/4" (8 Req.)	S27327
801A	Stud, 3/8 - 16 x 1-3/8" (4 Req.)	S09942
801B	Stud, 3/8 - 16 x 2-1/2" (2 Req.)	S04438
802A	Nut, 3/8 - 16 (4 Req.)	S23103
802B	Nut, 3/8 - 16 (2 Req.)	S23343
805	Washer, Lock	S23038
810	Plug, Pipe 1/2 NPT (6 Req.)	S23717
811	Fitting, Grease	S23700
831	Reducer, Eccentric	H05780

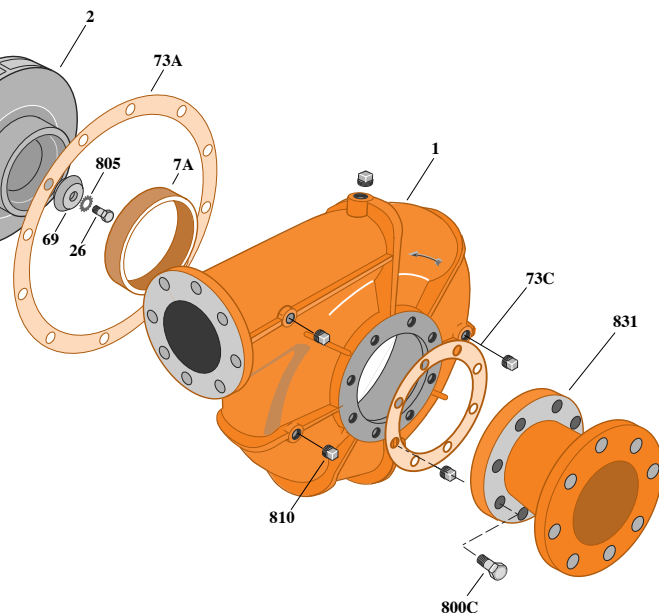

TABLE II

HP	PH	Bracket No.	"AK" Fit	"U" Dim.	Motor Frame
15	3	H02384	8-1/2"	1-1/4"	254TCZ/JP
20	3	H02384	8-1/2"	1-1/4"	256JP/TCZ
25	3	H01601	12-1/2"	1-1/4"	284JP
30	3	H01601	12-1/2"	1-1/4"	286JP
40	3	H01601	12-1/2"	1-1/4"	324JP/TCZ
50	3	H01601	12-1/2"	1-1/4"	326JP

NOTE: For an explanation of the tabulated material found on this page and for impeller key location, refer to *Supplement A* located at the beginning of this section.



TYPE "B" SINGLE STAGE CENTRIFUGAL PUMP Electric Motor Drive

Section	CC
Page	275.2
Date	January 1, 2004
Supersedes 9/1/97	

SILICON BRONZE IMPELLER

B4GPBHS

Flanged Case

Mechanical Shaft Seal Construction

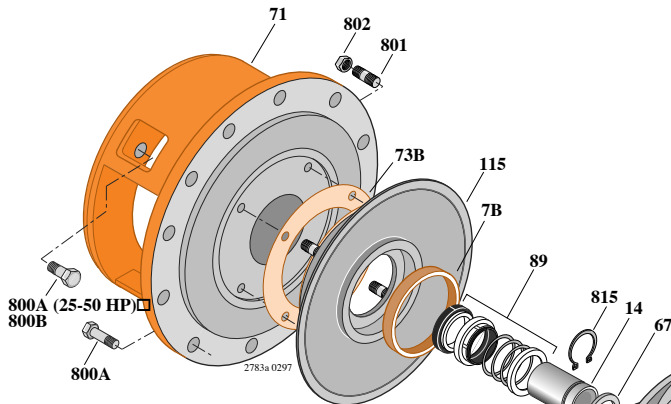
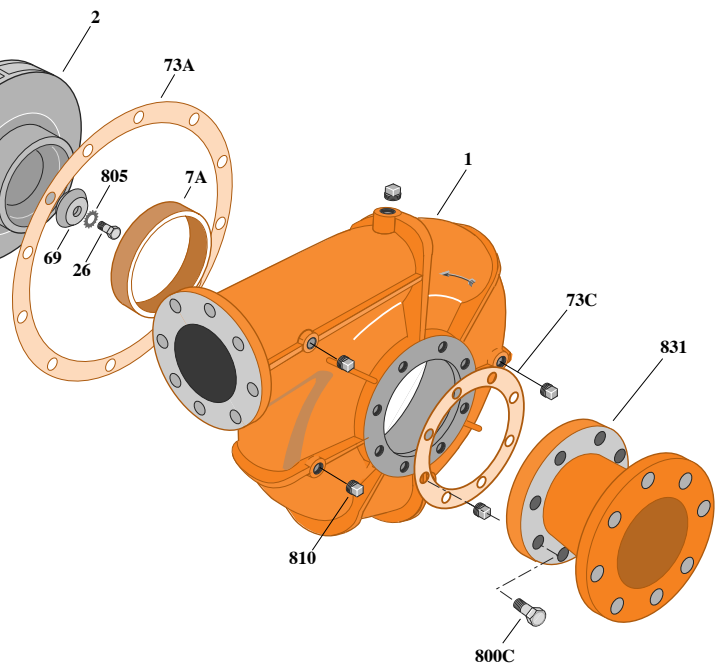

TABLE I

B/M No.	HP	PH	RPM	"U" Dim.	Imp. Dia.	Imp. No.
B75869	15	3	1750	1-1/4"	9.50"	M11268
B75863	20	3	1750	1-1/4"	10.31"	M11267
B75862	25	3	1750	1-1/4"	11.06"	M11266
B75861	30	3	1750	1-1/4"	11.69"	M11265
B75860	40	3	1750	1-1/4"	12.56"	M11264
B75279	50	3	1750	1-1/4"	12.75"	H05779



Item No.	Part Description	Part Number
1	Case, Volute	H05778
2	Impeller	See Table I
7A	Ring, Wearing	M11195
7B	Ring, Wearing	M11194
14	Sleeve, Shaft	S18869
26	Screw, Impeller 5/8 - 11 x 1-3/4"	S27001
67	Ring, Spacer	S19349
69	Deflector	S06319
71	Bracket	See Table II
73A	Gasket, Volute Case	S06271
73B	Gasket, Balance Ring	S09943
73C	Gasket, Eccentric Reducer	S10367
89	Seal, Mechanical Shaft	S32015
115	Ring, Balance	H05781
800A	Capscrew, 5/8 - 11 x 1-1/2" (16 Req.) (12-1/2 AK)	S26999
800A	Capscrew, 5/8 - 11 x 1-1/2" (12 Req.) (8-1/2 AK)	S26999
800B	Capscrew, 1/2 - 13 x 1-1/2" (4 Req.) (8-1/2 AK Only)	S26916
800C	Capscrew, 3/4" - 10 x 1-3/4" (8 Req.)	S27327
801	Stud, 3/8 - 16 x 1-3/8" (4 Req.)	S09942
802	Nut, 3/8 - 16 (4 Req.)	S23103
805	Washer, Lock	S23038
810	Plug, Pipe 1/2 NPT (6 Req.)	S23717
815	Ring, Retaining	S16767
831	Reducer, Eccentric	H05780

TABLE II

HP	PH	Bracket No.	"AK" Fit	"U" Dim.	Motor Frame
15	3	H03300	8-1/2"	1-1/4"	254JM
20	3	H03300	8-1/2"	1-1/4"	256JM
25	3	H03301	12-1/2"	1-1/4"	284JM
30	3	H03301	12-1/2"	1-1/4"	286JM
40	3	H03301	12-1/2"	1-1/4"	324JM
50	3	H03301	12-1/2"	1-1/4"	326JM

NOTE: For an explanation of the tabulated material found on this page and for impeller key location, refer to *Supplement A* located at the beginning of this section.



TYPE "B" SINGLE STAGE CENTRIFUGAL PUMP Electric Motor Drive

Section	CC
Page	275.3
Date	January 1, 2004
Supersedes NEW	

SILICON BRONZE IMPELLER

B4GPBH

Flanged Case

Packing Construction

TABLE I

B/M No.	HP	PH	RPM	"U" Dim.	Imp. Dia.	Imp. No.
B80470	15	3	1750	1-1/4"	9.50"	M11268
B80472	20	3	1750	1-1/4"	10.31"	M11267
B80474	25	3	1750	1-1/4"	11.06"	M11266
B80476	30	3	1750	1-1/4"	11.69"	M11265
B80478	40	3	1750	1-1/4"	12.56"	M11264
B80480	50	3	1750	1-1/4"	12.75"	H05779

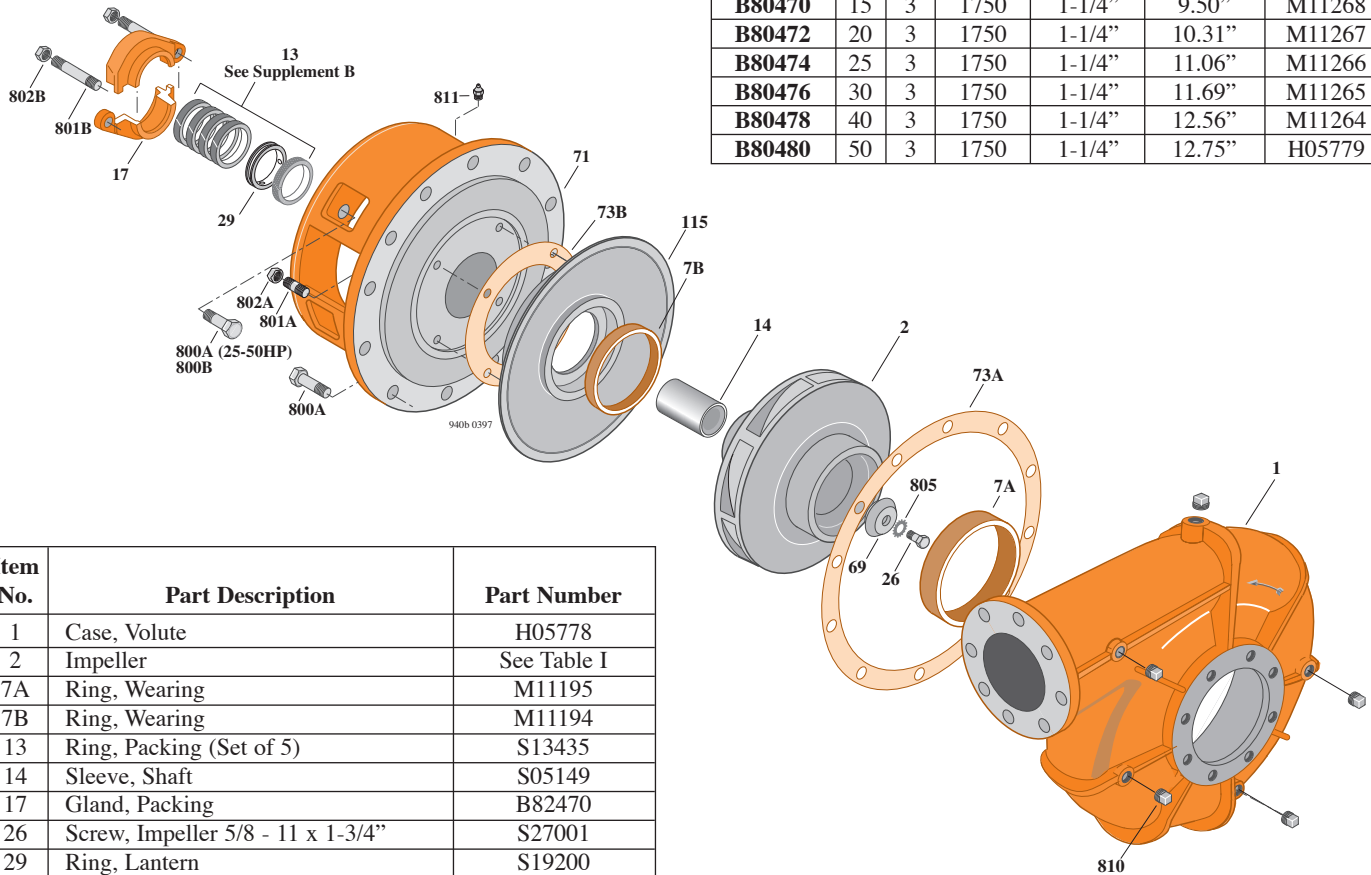

Item No.	Part Description	Part Number
1	Case, Volute	H05778
2	Impeller	See Table I
7A	Ring, Wearing	M11195
7B	Ring, Wearing	M11194
13	Ring, Packing (Set of 5)	S13435
14	Sleeve, Shaft	S05149
17	Gland, Packing	B82470
26	Screw, Impeller 5/8 - 11 x 1-3/4"	S27001
29	Ring, Lantern	S19200
69	Deflector	S06319
71	Bracket	See Table II
73A	Gasket, Volute Case	S06271
73B	Gasket, Balance Ring	S09943
115	Ring, Balance	H05781
800A	Capscrew, 5/8 - 11 x 1-1/2" (16 Req.) (12-1/2 AK)	S26999
800A	Capscrew, 5/8 - 11 x 1-1/2" (12 Req.) (8-1/2 AK)	S26999
800B	Capscrew, 1/2 - 13 x 1-1/2" (4 Req.) (8-1/2 AK Only)	S26916
801A	Stud, 3/8 - 16 x 1-3/8" (4 Req.)	S09942
801B	Stud, 3/8 - 16 x 2-1/2" (2 Req.)	S04438
802A	Nut, 3/8 - 16 (4 Req.)	S23103
802B	Nut, 3/8 - 16 (2 Req.)	S23343
805	Washer, Lock	S23038
810	Plug, Pipe 1/2 NPT (6 Req.)	S23717
811	Fitting, Grease	S23700

TABLE II

HP	PH	Bracket No.	"AK" Fit	"U" Dim.	Motor Frame
15	3	H02384	8-1/2"	1-1/4"	254TCZ/JP
20	3	H02384	8-1/2"	1-1/4"	256JP/TCZ
25	3	H01601	12-1/2"	1-1/4"	284JP
30	3	H01601	12-1/2"	1-1/4"	286JP
40	3	H01601	12-1/2"	1-1/4"	324JP/TCZ
50	3	H01601	12-1/2"	1-1/4"	326JP

NOTE: For an explanation of the tabulated material found on this page and for impeller key location, refer to *Supplement A* located at the beginning of this section.



TYPE "B" SINGLE STAGE CENTRIFUGAL PUMP Electric Motor Drive

Section	CC
Page	275.4
Date	January 1, 2004
Supersedes NEW	

SILICON BRONZE IMPELLER

B4GPBHS

Flanged Case

Mechanical Shaft Seal Construction

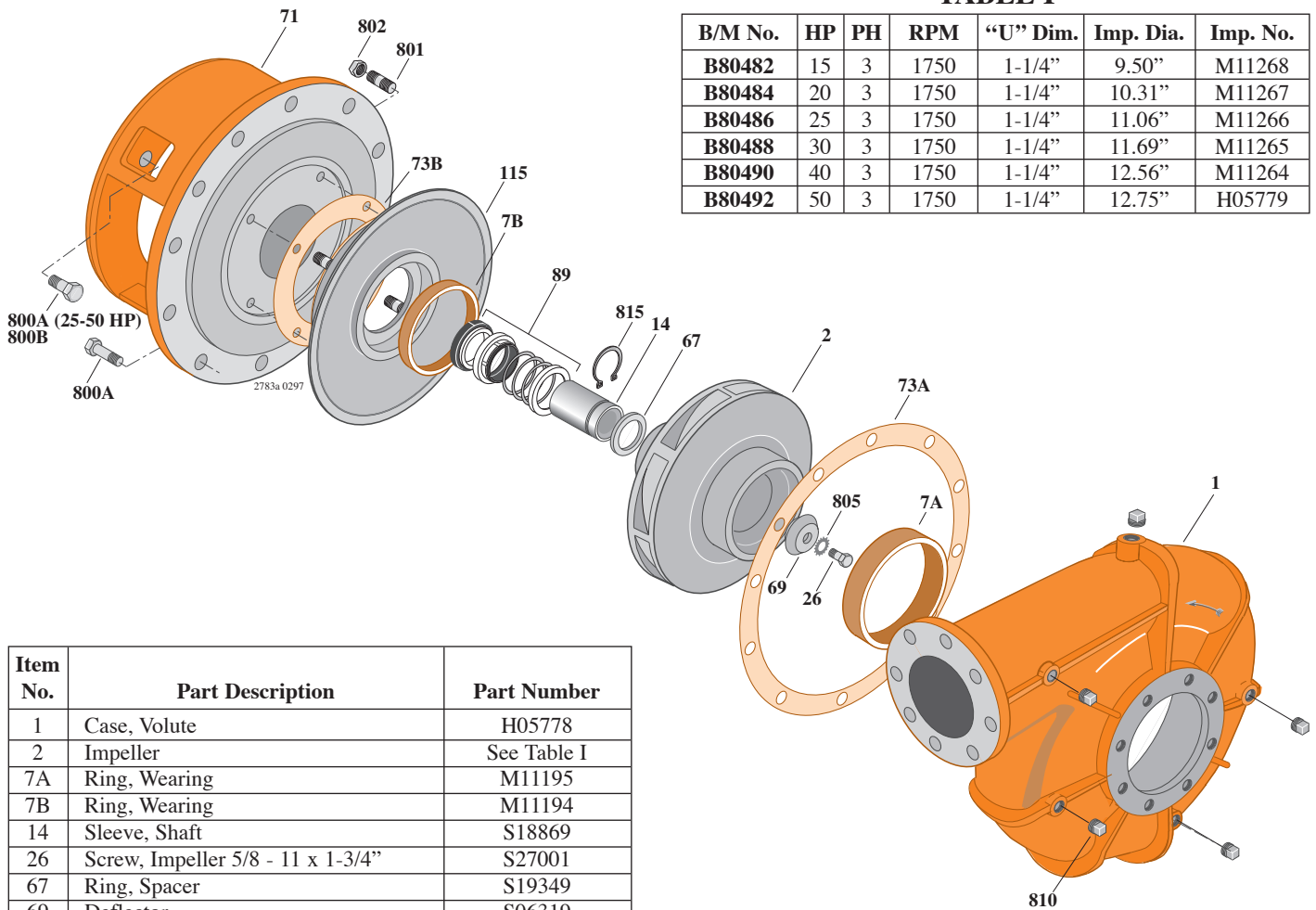

TABLE I

B/M No.	HP	PH	RPM	"U" Dim.	Imp. Dia.	Imp. No.
B80482	15	3	1750	1-1/4"	9.50"	M11268
B80484	20	3	1750	1-1/4"	10.31"	M11267
B80486	25	3	1750	1-1/4"	11.06"	M11266
B80488	30	3	1750	1-1/4"	11.69"	M11265
B80490	40	3	1750	1-1/4"	12.56"	M11264
B80492	50	3	1750	1-1/4"	12.75"	H05779

Item No.	Part Description	Part Number
1	Case, Volute	H05778
2	Impeller	See Table I
7A	Ring, Wearing	M11195
7B	Ring, Wearing	M11194
14	Sleeve, Shaft	S18869
26	Screw, Impeller 5/8 - 11 x 1-3/4"	S27001
67	Ring, Spacer	S19349
69	Deflector	S06319
71	Bracket	See Table II
73A	Gasket, Volute Case	S06271
73B	Gasket, Balance Ring	S09943
89	Seal, Mechanical Shaft	S32015
115	Ring, Balance	H05781
800A	Capscrew, 5/8 - 11 x 1-1/2" (16 Req.) (12-1/2 AK)	S26999
800A	Capscrew, 5/8 - 11 x 1-1/2" (12 Req.) (8-1/2 AK)	S26999
800B	Capscrew, 1/2 - 13 x 1-1/2" (4 Req.) (8-1/2 AK Only)	S26916
801	Stud, 3/8 - 16 x 1-3/8" (4 Req.)	S09942
802	Nut, 3/8 - 16 (4 Req.)	S23103
805	Washer, Lock	S23038
810	Plug, Pipe 1/2 NPT (6 Req.)	S23717
815	Ring, Retaining	S16767

TABLE II

HP	PH	Bracket No.	"AK" Fit	"U" Dim.	Motor Frame
15	3	H03300	8-1/2"	1-1/4"	254JM
20	3	H03300	8-1/2"	1-1/4"	256JM
25	3	H03301	12-1/2"	1-1/4"	284JM
30	3	H03301	12-1/2"	1-1/4"	286JM
40	3	H03301	12-1/2"	1-1/4"	324JM
50	3	H03301	12-1/2"	1-1/4"	326JM

NOTE: For an explanation of the tabulated material found on this page and for impeller key location, refer to *Supplement A* located at the beginning of this section.