



# TYPE "B" SINGLE STAGE CENTRIFUGAL PUMP Electric Motor Drive

Section	CC
Page	300.1
Date	January 1, 2004
Supersedes 6/1/95	

## CAST IRON IMPELLER

## B4EYPBH

### Flanged Case

### Packing Construction

**TABLE I**

B/M No.	HP	PH	RPM	"U" Dim.	Imp. Dia.	Imp. No.
B55982	100	3	1800	1-5/8"	17.25"	L06192
B55983	125	3	1800	1-5/8"	17.88"	L02577

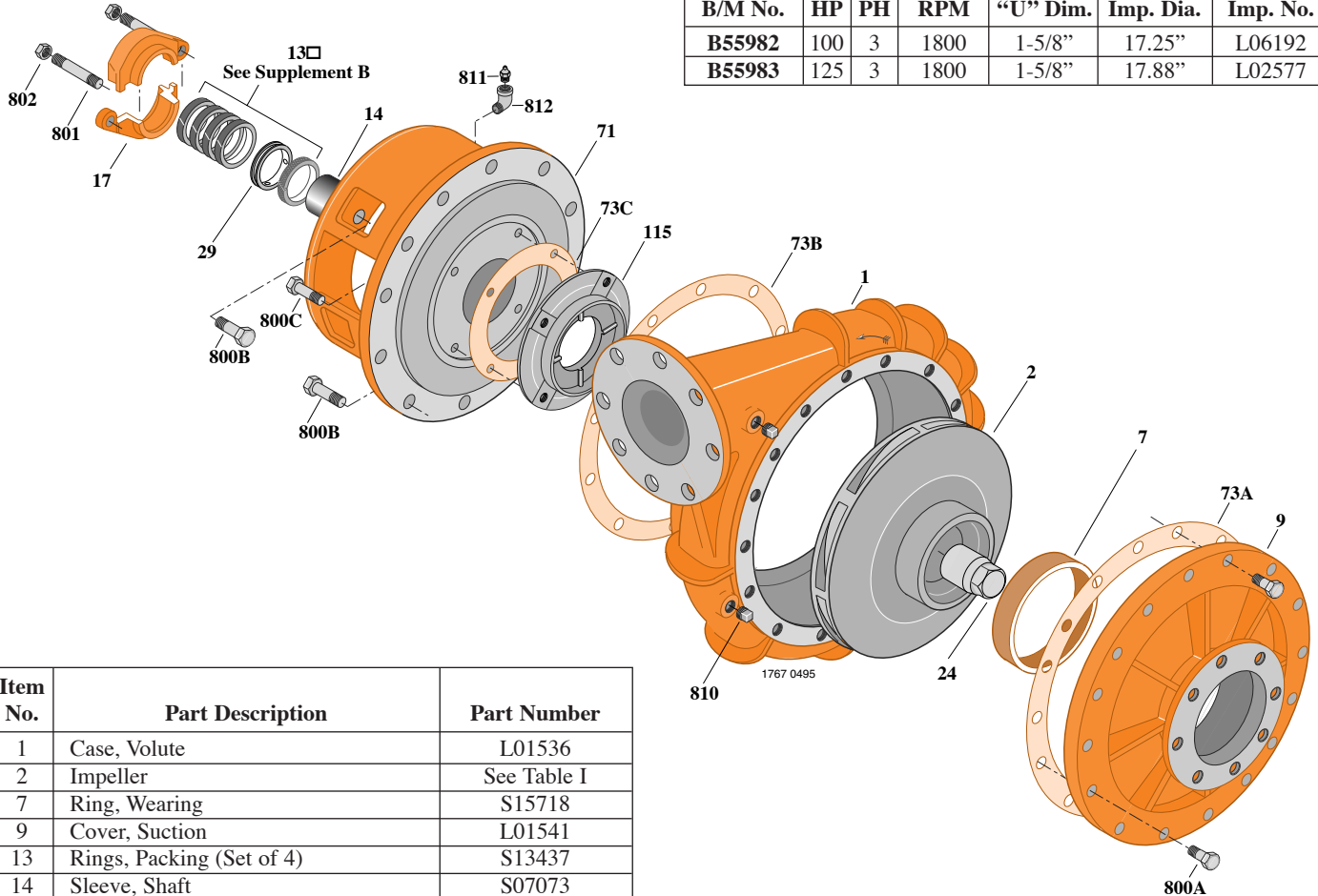

Item No.	Part Description	Part Number
1	Case, Volute	L01536
2	Impeller	See Table I
7	Ring, Wearing	S15718
9	Cover, Suction	L01541
13	Rings, Packing (Set of 4)	S13437
14	Sleeve, Shaft	S07073
17	Gland, Packing	B82471
24	Locknut, Impeller	S07829
29	Ring, Lantern	S19198
32	Key, 1/4 x 2-1/4" (See Note)	S23677
71	Bracket	See Table II
73A	Gasket, Suction Cover	S06401
73B	Gasket, Volute	S06271
73C	Gasket, Balance Ring	S09943
115	Ring, Balance	S13655
800A	Capscrew, 5/8 - 11 x 1-3/4" (20 Req.)	S27001
800B	Capscrew, 5/8 - 11 x 1-1/2" (12 Req.)	S26999
800C	Capscrew, 3/8 - 16 x 1-1/2" (4 Req.)	S26830
801	Stud, 3/8 - 16 x 2-1/2" (2 Req.)	S04438
802	Nut, Hex 3/8 - 16 (2 Req.)	S23343
810	Plug, Pipe 1/2 NPT (4 Req.)	S23717
811	Fitting, Grease	S23700
812	Elbow, Street	S25421

**TABLE II**

HP	PH	Bracket No.	"AK" Fit	"U" Dim.	Motor Frame
100	3	H03622	12-1/2"	1-5/8"	404TC
125	3	H03622	12-1/2"	1-5/8"	405TC

**NOTE:** For an explanation of the tabulated material found on this page and for impeller key location, refer to *Supplement A* located at the beginning of this section.



# TYPE "B" SINGLE STAGE CENTRIFUGAL PUMP Electric Motor Drive

Section	CC
Page	300.1.1
Date	November 2, 2009
Supersedes 12/1/05	

## CAST IRON IMPELLER

## B4EYPBH

### Flanged Case

### Packing Construction

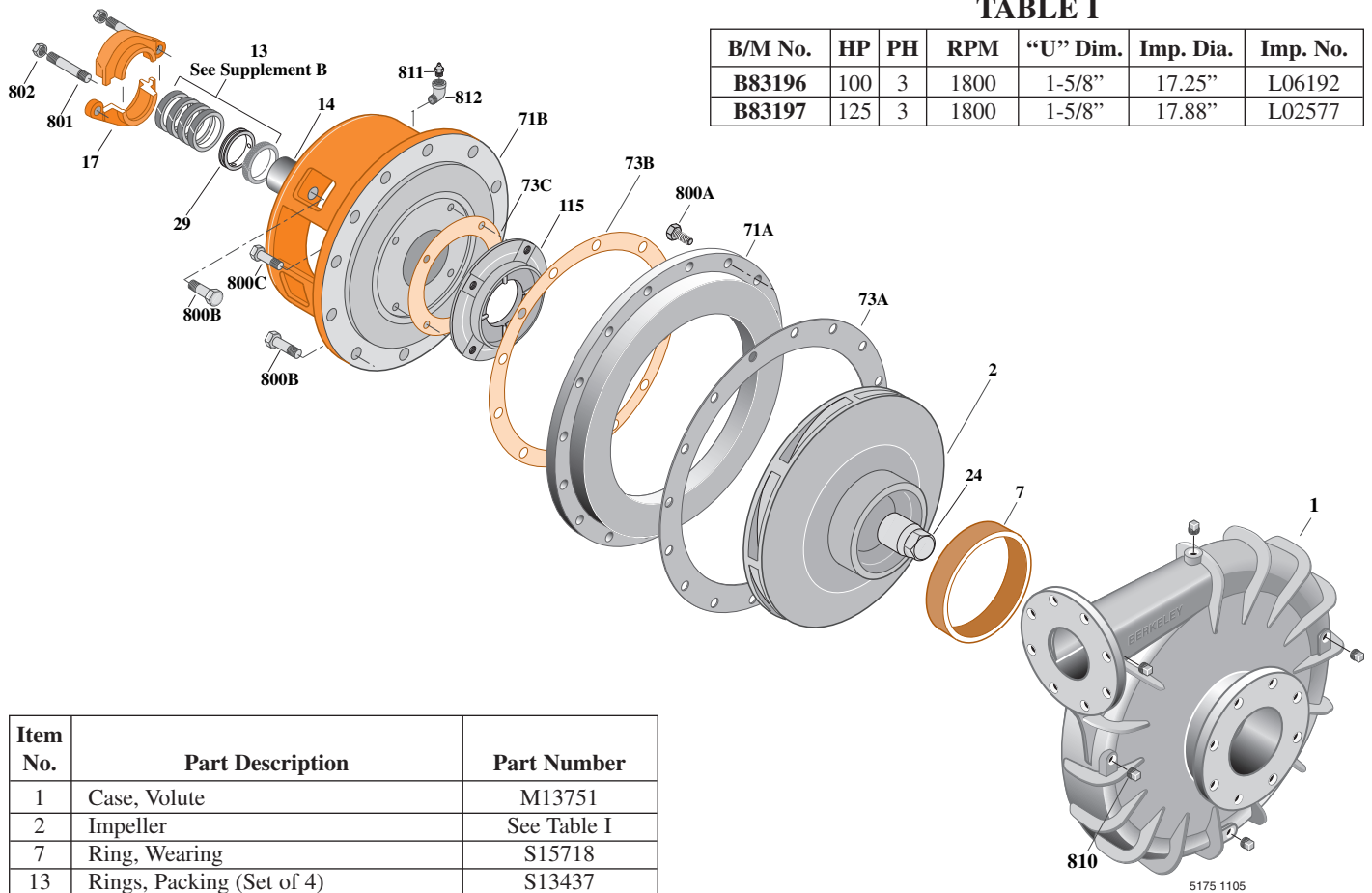

**TABLE I**

B/M No.	HP	PH	RPM	"U" Dim.	Imp. Dia.	Imp. No.
<b>B83196</b>	100	3	1800	1-5/8"	17.25"	L06192
<b>B83197</b>	125	3	1800	1-5/8"	17.88"	L02577

Item No.	Part Description	Part Number
1	Case, Volute	M13751
2	Impeller	See Table I
7	Ring, Wearing	S15718
13	Rings, Packing (Set of 4)	S13437
14	Sleeve, Shaft	S07073L
17	Gland, Packing	B82471
24	Locknut, Impeller	S07829
29	Ring, Lantern	S19198
32	Key, 1/4 x 2-1/4" (See Note)	S23677
71A	Ring, Adapter	M13753
71B	Bracket	See Table II
73A	Gasket, Suction Cover	S06401
73B	Gasket, Volute	S06271
73C	Gasket, Balance Ring	S09943
115	Ring, Balance	S13655
800A	Capscrew, 5/8 - 11 x 1-3/4" (20 Req.)	S27001
800B	Capscrew, 5/8 - 11 x 1-1/2" (12 Req.)	S26999
800C	Capscrew, 3/8 - 16 x 1-1/2" (4 Req.)	S26830
801	Stud, 3/8 - 16 x 2-1/2" (2 Req.)	S04438
802	Nut, Hex 3/8 - 16 (2 Req.)	S23343
810	Plug, Pipe 1/2 NPT (4 Req.)	S23717
811	Fitting, Grease	S23700
812	Elbow, Street	S25421

**TABLE II**

HP	PH	Bracket No.	"AK" Fit	"U" Dim.	Motor Frame
100	3	H03622	12-1/2"	1-5/8"	404TC
125	3	H03622	12-1/2"	1-5/8"	405TC

**NOTE:** For an explanation of the tabulated material found on this page and for impeller key location, refer to *Supplement A* located at the beginning of this section.