



# TYPE "B" SINGLE STAGE CENTRIFUGAL PUMP Electric Motor Drive

Section	CC
Page	280.1
Date	January 1, 2004
Supersedes 6/1/95	

## CAST IRON IMPELLER

## B4EXPBL

### Flanged Case

### Packing Construction

**TABLE I**

B/M No.	HP	PH	RPM	"U" Dim.	Imp. Dia.	Imp. No.
<b>B55975</b>	60	3	1800	1-5/8"	14.50"	H03900
<b>B55976</b>	75	3	1800	1-5/8"	15.50"	H03529

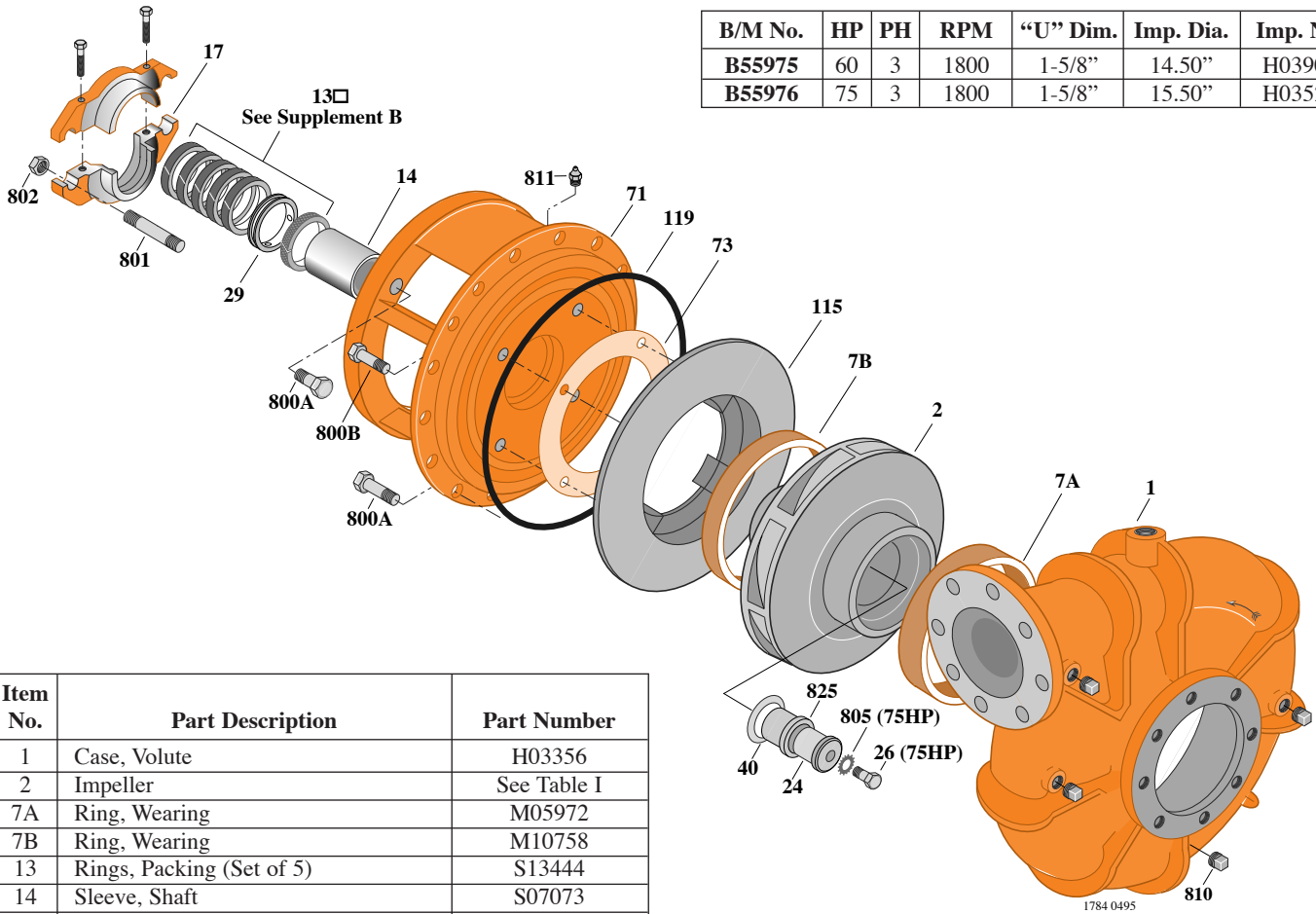

Item No.	Part Description	Part Number
1	Case, Volute	H03356
2	Impeller	See Table I
7A	Ring, Wearing	M05972
7B	Ring, Wearing	M10758
13	Rings, Packing (Set of 5)	S13444
14	Sleeve, Shaft	S07073
17	Gland, Packing	B82473
24	Locknut, Impeller	S19868
26	Screw, Impeller 1/2 - 13 x 3-1/2"	S23633
29	Ring, Lantern	S19198
32	Key, 3/8 x 2-1/4" (See Note)	S23940
40	Deflector	S19864
71	Bracket	See Table II
73	Gasket, Balance Ring	S09943
115	Ring, Balance	M06728
119	O-Ring	S14444
800A	Capscrew, 5/8 - 11 x 1-3/4" (20 Req.)	S27001
800B	Capscrew, 3/8 - 16 x 1" (4 Req.)	S26826
801	Stud, 1/2 - 13 x 3-3/4" (2 Req.)	S08305
802	Nut, Hex 1/2 - 13 x 7/16" (2 Req.)	S23347
805	Washer, Lock	S23038
810	Plug, Pipe 1/2 NPT (4 Req.)	S23717
811	Fitting, Grease	S23700
825	Sleeve, Impeller Locknut	S19865

**TABLE II**

HP	PH	Bracket No.	"AK" Fit	"U" Dim.	Motor Frame
60	3	H03684	12-1/2"	1-5/8"	364JP
75	3	H03684	12-1/2"	1-5/8"	365JP

**NOTE:** For an explanation of the tabulated material found on this page and for impeller key location, refer to *Supplement A* located at the beginning of this section.