



Type "B" Single Stage Centrifugal Pump Electric Motor Drive

Section	CC
Page	180.1
Date	July 1, 2011
Supersedes 1/1/04	

CAST IRON IMPELLER

B3ZPL

Threaded Case (NPT)

Packing Construction

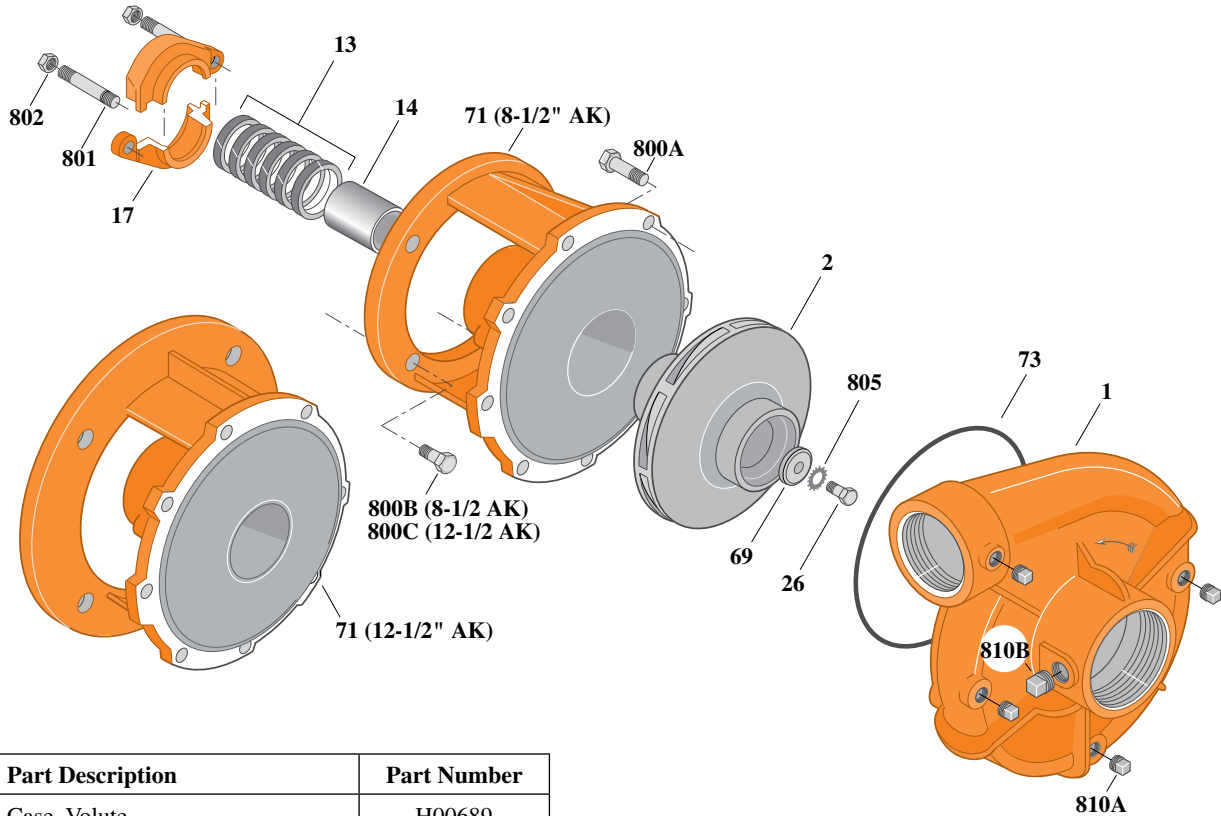

Item	Part Description	Part Number
1	Case, Volute	H00689
2	Impeller	See Table I
13	Rings, Packing (Set of 6)	S13470
14	Sleeve, Shaft	S05149L
17	Gland, Packing	B82470
26	Screw, Impeller 1/2 - 13 x 1-1/2"	S23623
32	Key, 1/4 x 2-1/4" (See Note 1)	S23677
69	Washer, Impeller	S06319
71	Bracket	See Table II
73	O-Ring (See Note 2)	M14943
800A	Capscrew, 3/8 - 16 x 1-1/8" (8 Req.)	S26827
800B	Capscrew, 1/2 - 13 x 1-1/2" (4 Req.)	S26916
800C	Capscrew, 5/8 - 11 x 1-1/2" (4 Req.)	S26999
801	Stud, 3/8 - 16 x 4" (2 Req.)	S08303
802	Nut, Hex 3/8 - 16 (2 Req.)	S23343
805	Washer, Lock	S23038
810A	Plug, Pipe 1/4 NPT (4 Req.)	S23715
810B	Plug, Pipe 1/2 NPT	S23717

Table I

B/M No.	HP	PH	RPM	"U" Dim.	Imp. Dia.	Imp. No.
B51634	20	3	3600	1-1/4"	6.75"	M07705
B51635	25	3	3600	1-1/4"	7.25"	M07706
B53818	30	3	3600	1-1/4"	7.75"	M07707
B53819	40	3	3600	1-1/4"	8.62"	M07708
B51638	50	3	3600	1-1/4"	9.00"	M03380

Table II

HP	PH	Bracket No.	"AK" Fit	"U" Dim.	Motor Frame
20	3	L03827	8-1/2"	1-1/4"	254JP
25	3	L03827	8-1/2"	1-1/4"	256JP
30	3	L01563	12-1/2"	1-1/4"	284JP
40	3	L01563	12-1/2"	1-1/4"	286JP
50	3	L01563	12-1/2"	1-1/4"	324JP

NOTE 1: For an explanation of the tabulated material found on this page and for impeller key location, refer to *Supplement A* located at the beginning of this section.

NOTE 2: Also accepts gasket S05126 as replacement for o-ring. See *Supplement E* located at the beginning of this section.



Type "B" Single Stage Centrifugal Pump Electric Motor Drive

Section	CC
Page	180.2
Date	July 1, 2011
Supersedes 1/1/04	

CAST IRON IMPELLERB3ZPL

Flanged Case

Packing Construction

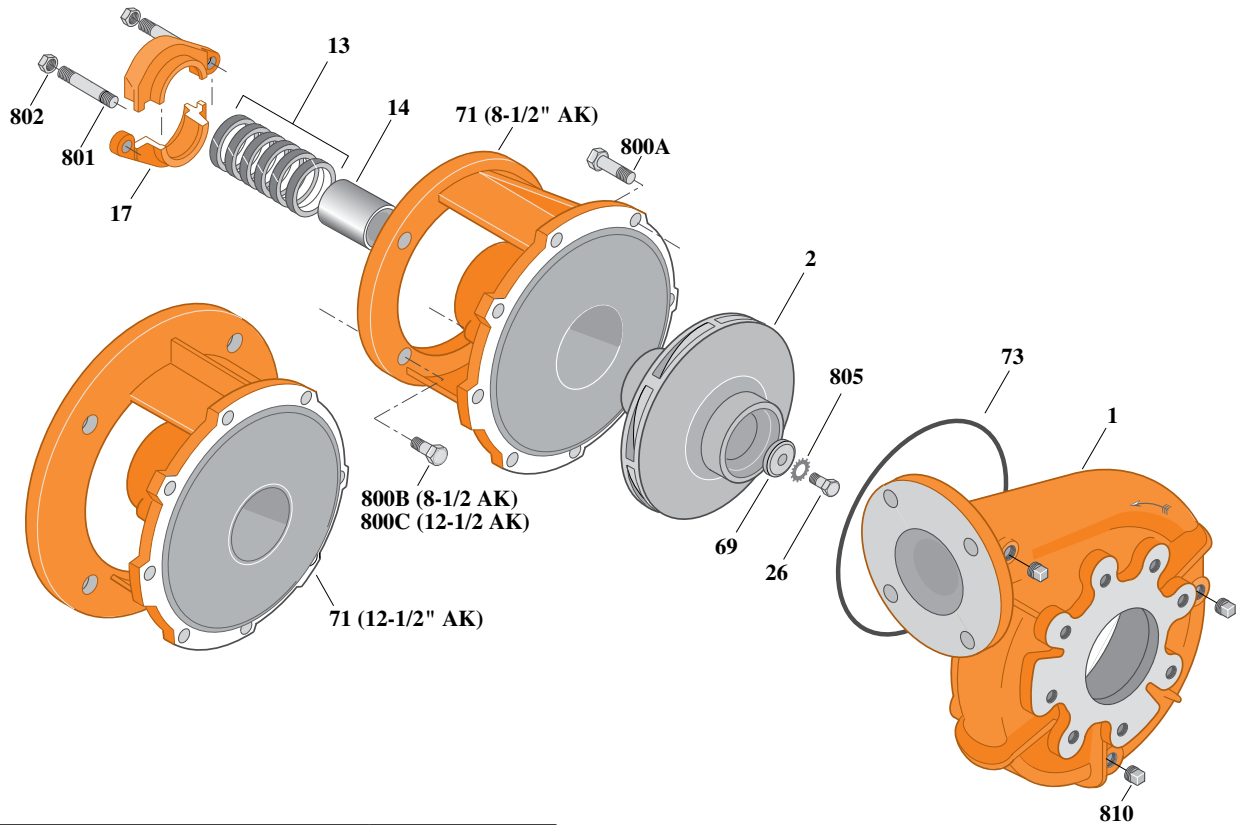

Item	Part Description	Part Number
1	Case, Volute	H05130
2	Impeller	See Table I
13	Rings, Packing (Set of 6)	S13470
14	Sleeve, Shaft	S05149L
17	Gland, Packing	B82470
26	Screw, Impeller 1/2 - 13 x 1-1/2"	S23623
32	Key, 1/4 x 2-1/4" (See Note 1)	S23677
69	Washer, Impeller	S06319
71	Bracket	See Table II
73	O-Ring (See Note 2)	M14943
800A	Capscrew, 3/8 - 16 x 1" (8 Req.)	S26826
800B	Capscrew, 1/2 - 13 x 1-1/2" (4 Req.)	S26916
800C	Capscrew, 5/8 - 11 x 1-1/2" (4 Req.)	S26999
801	Stud, 3/8 - 16 x 4" (2 Req.)	S08303
802	Nut, Hex 3/8 - 16 (2 Req.)	S23343
805	Washer, Lock	S23038
810	Plug, Pipe 1/4 NPT (3 Req.)	S23715

Table I

B/M No.	HP	PH	RPM	"U" Dim.	Imp. Dia.	Imp. No.
B70206	20	3	3600	1-1/4"	6.75"	M07705
B70209	25	3	3600	1-1/4"	7.25"	M07706
B70212	30	3	3600	1-1/4"	7.75"	M07707
B70215	40	3	3600	1-1/4"	8.62"	M07708
B70218	50	3	3600	1-1/4"	9.00"	M03380

Table II

HP	PH	Bracket No.	"AK" Fit	"U" Dim.	Motor Frame
20	3	L03827	8-1/2"	1-1/4"	254JP
25	3	L03827	8-1/2"	1-1/4"	256JP
30	3	L01563	12-1/2"	1-1/4"	284JP
40	3	L01563	12-1/2"	1-1/4"	286JP
50	3	L01563	12-1/2"	1-1/4"	324JP

NOTE 1: For an explanation of the tabulated material found on this page and for impeller key location, refer to *Supplement A* located at the beginning of this section.

NOTE 2: Also accepts gasket S05126 as replacement for o-ring. See *Supplement E* located at the beginning of this section.



Type "B" Single Stage Centrifugal Pump Electric Motor Drive

Section	CC
Page	180.3
Date	July 1, 2011
Supersedes 1/1/04	

CAST IRON IMPELLER

B3ZPLS

Threaded Case (NPT)

Mechanical Shaft Seal Construction

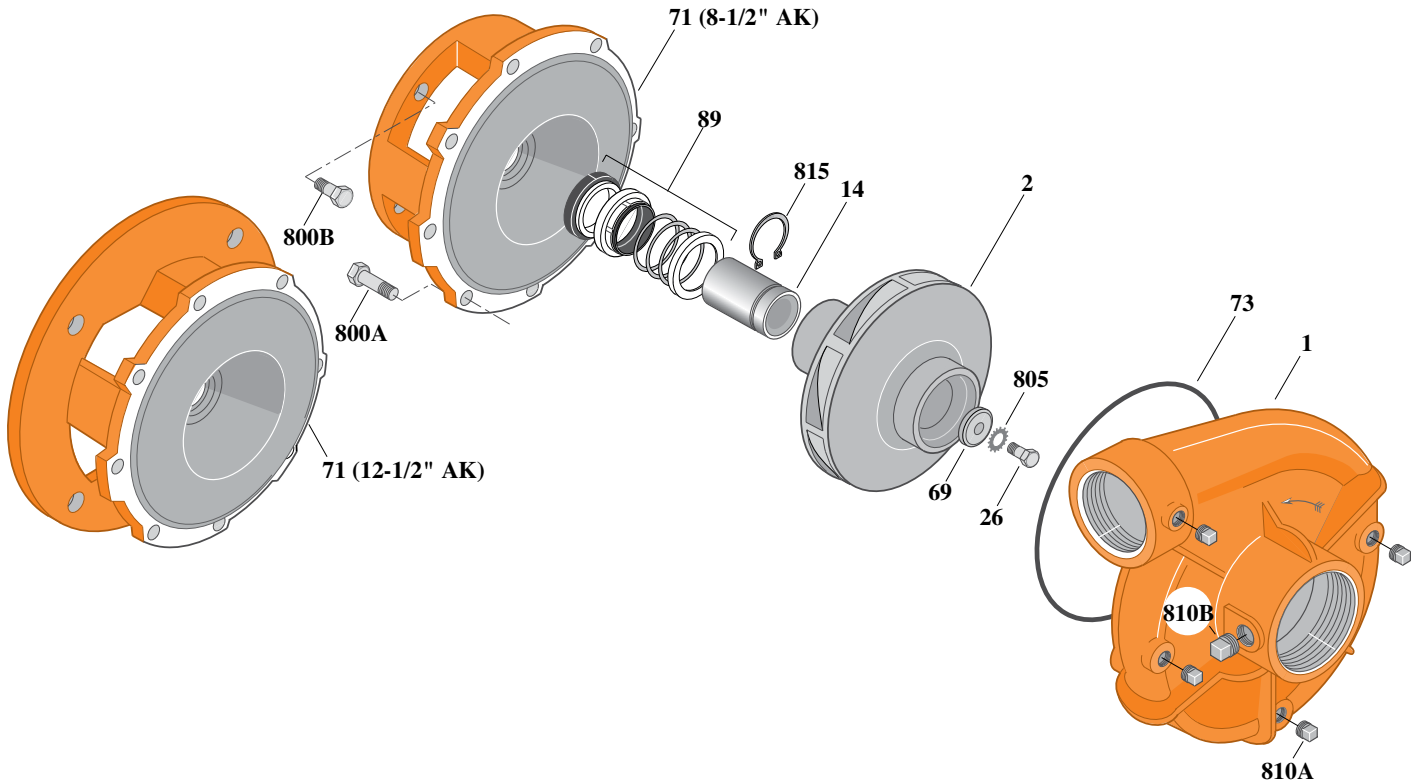

Item	Part Description	Part Number
1	Case, Volute	H00689
2	Impeller	See Table I
14	Sleeve, Shaft	S18869L
26	Screw, Impeller 1/2 - 13 x 1-1/4"	S23623
32	Key, 1/4 x 2-1/4" (See Note 1)	S23677
69	Washer, Impeller	S06319
71	Bracket	See Table II
73	O-Ring (See Note 2)	M14943
89	Seal, Mechanical Shaft	S32015
800A	Capscrew, 3/8 - 16 x 1" (8 Req.)	S26826
800B	Capscrew, 1/2 - 13 x 1" (4 Req.) (For 8-1/2 AK)	S26912
800B	Capscrew, 5/8 - 11 x 1-1/4" (4 Req.) (For 12-1/2 AK)	S26997
805	Washer, Lock	S23038
810A	Plug, Pipe 1/4 NPT (4 Req.)	S23715
810B	Plug, Pipe 1/2 NPT	S23717
815	Ring, Retaining	S16767

Table I

B/M No.	HP	PH	RPM	"U" Dim.	Imp. Dia.	Imp. No.
B54112	20	3	3600	1-1/4"	6.75"	M07705
B54113	25	3	3600	1-1/4"	7.25"	M07706
B54114	30	3	3600	1-1/4"	7.75"	M07707
B54115	40	3	3600	1-1/4"	8.62"	M07708
B54116	50	3	3600	1-1/4"	9.00"	M03380

Table II

HP	PH	Bracket No.	"AK" Fit	"U" Dim.	Motor Frame
20	3	L04615	8-1/2"	1-1/4"	254JM
25	3	L04615	8-1/2"	1-1/4"	256JM
30	3	L04627	12-1/2"	1-1/4"	284JM
40	3	L04627	12-1/2"	1-1/4"	286JM
50	3	L04627	12-1/2"	1-1/4"	324JM

NOTE 1: For an explanation of the tabulated material found on this page and for impeller key location, refer to *Supplement A* located at the beginning of this section.

NOTE 2: Also accepts gasket S05126 as replacement for o-ring. See *Supplement E* located at the beginning of this section.



Type "B" Single Stage Centrifugal Pump Electric Motor Drive

Section	CC
Page	180.4
Date	July 1, 2011
Supersedes 1/1/04	

CAST IRON IMPELLERB3ZPLS

Flanged Case

Mechanical Shaft Seal Construction

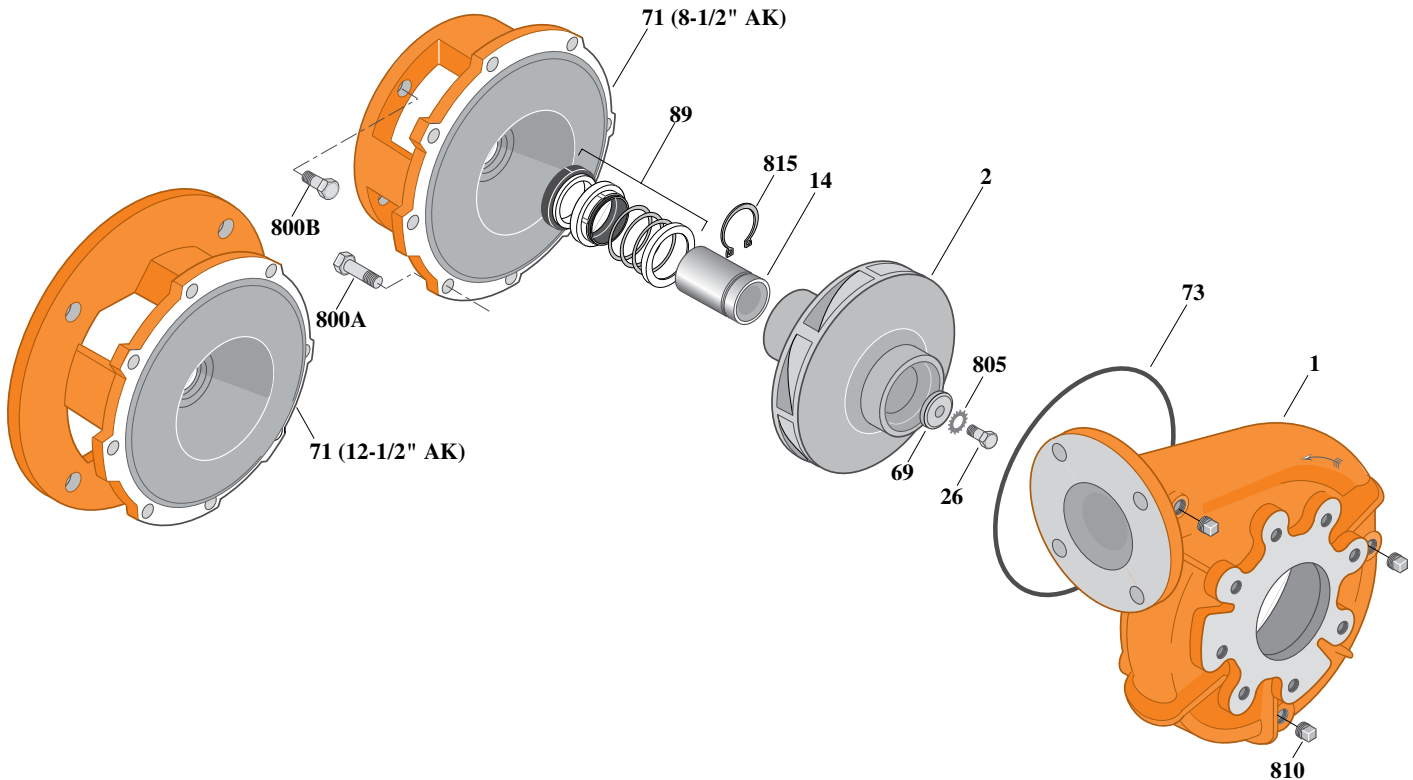

Table I

B/M No.	HP	PH	RPM	"U" Dim.	Imp. Dia.	Imp. No.
B70221	20	3	3600	1-1/4"	6.75"	M07705
B70224	25	3	3600	1-1/4"	7.25"	M07706
B70227	30	3	3600	1-1/4"	7.75"	M07707
B70230	40	3	3600	1-1/4"	8.62"	M07708
B70233	50	3	3600	1-1/4"	9.00"	M03380

Table II

HP	PH	Bracket No.	"AK" Fit	"U" Dim.	Motor Frame
20	3	L04615	8-1/2"	1-1/4"	254JM
25	3	L04615	8-1/2"	1-1/4"	256JM
30	3	L04627	12-1/2"	1-1/4"	284JM
40	3	L04627	12-1/2"	1-1/4"	286JM
50	3	L04627	12-1/2"	1-1/4"	324JM

NOTE 1: For an explanation of the tabulated material found on this page and for impeller key location, refer to **Supplement A** located at the beginning of this section.

NOTE 2: Also accepts gasket S05126 as replacement for o-ring. See **Supplement E** located at the beginning of this section.

Item	Part Description	Part Number
1	Case, Volute	H05130
2	Impeller	See Table I
14	Sleeve, Shaft	S18869L
26	Screw, Impeller 1/2 - 13 x 1-1/2"	S23623
32	Key, 1/4 x 2-1/4" (See Note 1)	S23677
69	Washer, Impeller	S06319
71	Bracket	See Table II
73	O-Ring (See Note 2)	M14943
89	Seal, Mechanical Shaft	S32015
800A	Capscrew, 3/8 - 16 x 1" (8 Req.)	S26826
800B	Capscrew, 1/2 - 13 x 1" (4 Req.) (For 8-1/2 AK)	S26912
800B	Capscrew, 5/8 - 11 x 1-1/4" (4 Req.) (For 12-1/2 AK)	S26997
805	Washer, Lock	S23038
810	Plug, Pipe 1/4 NPT (3 Req.)	S23715
815	Ring, Retaining	S16767



Type "B" Single Stage Centrifugal Pump Electric Motor Drive

Section	CC
Page	180.5
Date	July 1, 2011
Supersedes 1/1/04	

BRONZE IMPELLER

B3ZPL

Threaded Case (NPT)

Packing Construction

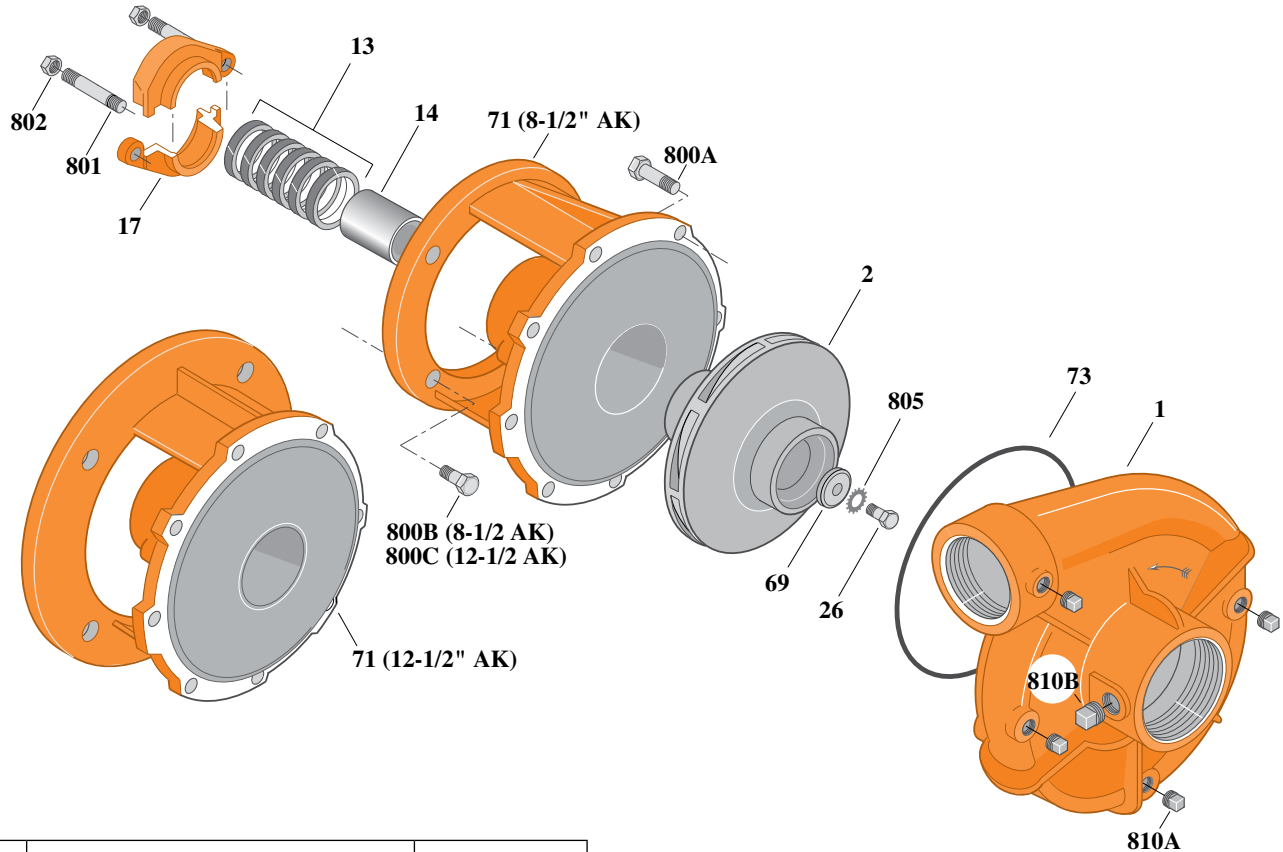

Item	Part Description	Part Number
1	Case, Volute	H00689
2	Impeller	See Table I
13	Rings, Packing (Set of 6)	S13470
14	Sleeve, Shaft	S05149L
17	Gland, Packing	B82470
26	Screw, Impeller 1/2 - 13 x 1-1/2"	S23623
32	Key, 1/4 x 2-1/4" (See Note 1)	S23677
69	Washer, Impeller	S06319
71	Bracket	See Table II
73	O-Ring (See Note 2)	M14943
800A	Capscrew, 3/8 - 16 x 1-1/8" (8 Req.)	S26827
800B	Capscrew, 1/2 - 13 x 1-1/2" (4 Req.)	S26916
800C	Capscrew, 5/8 - 11 x 1-1/2" (4 Req.)	S26999
801	Stud, 3/8 - 16 x 4" (2 Req.)	S08303
802	Nut, Hex 3/8 - 16 (2 Req.)	S23343
805	Washer, Lock	S23038
810A	Plug, Pipe 1/4 NPT (4 Req.)	S23715
810B	Plug, Pipe 1/2 NPT	S23717

Table I

B/M No.	HP	PH	RPM	"U" Dim.	Imp. Dia.	Imp. No.
B66674						
B66688						
B66694						
B66700						
B66845						

These B/M Numbers
Are No Longer Available.

See Page 180.6.1 for Current Models.

Table II

HP	PH	Bracket No.	"AK" Fit	"U" Dim.	Motor Frame
20	3	L03827	8-1/2"	1-1/4"	254JP
25	3	L03827	8-1/2"	1-1/4"	256JP
30	3	L01563	12-1/2"	1-1/4"	284JP
40	3	L01563	12-1/2"	1-1/4"	286JP
50	3	L01563	12-1/2"	1-1/4"	324JP

NOTE 1: For an explanation of the tabulated material found on this page and for impeller key location, refer to **Supplement A** located at the beginning of this section.

NOTE 2: Also accepts gasket S05126 as replacement for o-ring. See **Supplement E** located at the beginning of this section.



Type "B" Single Stage Centrifugal Pump Electric Motor Drive

Section	CC
Page	180.6
Date	July 1, 2011
Supersedes 1/1/04	

BRONZE IMPELLERB3ZPL

Flanged Case

Packing Construction

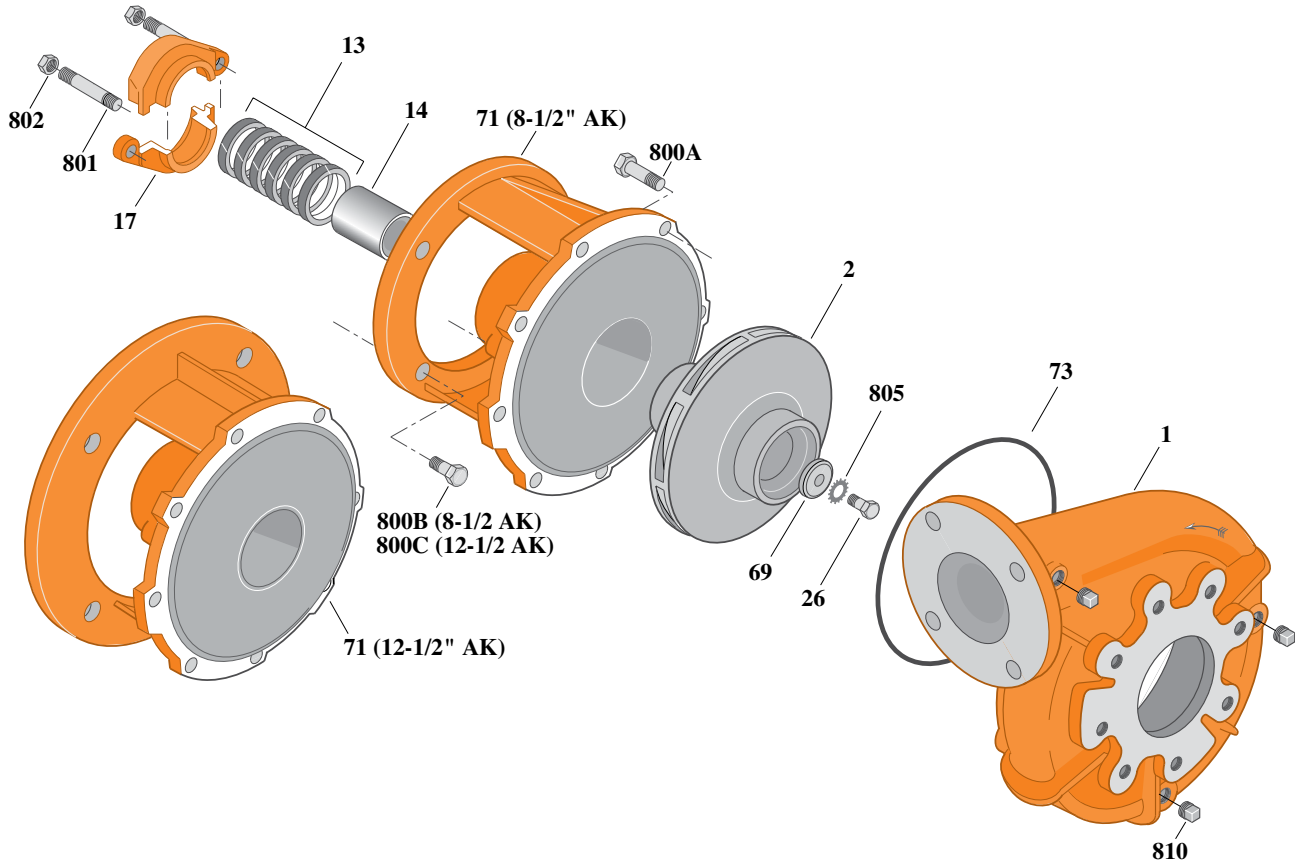

Item	Part Description	Part Number
1	Case, Volute	H05130
2	Impeller	See Table I
13	Rings, Packing (Set of 6)	S13470
14	Sleeve, Shaft	S05149L
17	Gland, Packing	B82470
26	Screw, Impeller 1/2 - 13 x 1-1/2"	S23623
32	Key, 1/4 x 2-1/4" (See Note 2)	S23677
69	Washer, Impeller	S06319
71	Bracket	See Table II
73	O-Ring (See Note 2)	M14943
800A	Capscrew, 3/8 - 16 x 1" (8 Req.)	S26826
800B	Capscrew, 1/2 - 13 x 1-1/2" (4 Req.)	S26916
800C	Capscrew, 5/8 - 11 x 1-1/2" (4 Req.)	S26999
801	Stud, 3/8 - 16 x 4" (2 Req.)	S08303
802	Nut, Hex 3/8 - 16 (2 Req.)	S23343
805	Washer, Lock	S23038
810	Plug, Pipe 1/4 NPT (3 Req.)	S23715

Table I

B/M No.	HP	PH	RPM	"U" Dim.	Imp. Dia.	Imp. No.
B70181	20	3	3600	1-1/4"	6.75"	L06598
B70184	25	3	3600	1-1/4"	7.25"	L06599
B70187	30	3	3600	1-1/4"	7.75"	L06600
B70190	40	3	3600	1-1/4"	8.62"	L06601
B70193	50	3	3600	1-1/4"	9.00"	L06659

Table I

HP	PH	Bracket No.	"AK" Fit	"U" Dim.	Motor Frame
20	3	L03827	8-1/2"	1-1/4"	254JP
25	3	L03827	8-1/2"	1-1/4"	256JP
30	3	L01563	12-1/2"	1-1/4"	284JP
40	3	L01563	12-1/2"	1-1/4"	286JP
50	3	L01563	12-1/2"	1-1/4"	324JP

NOTE 1: For an explanation of the tabulated material found on this page and for impeller key location, refer to *Supplement A* located at the beginning of this section.

NOTE 2: Also accepts gasket S05126 as replacement for o-ring. See *Supplement E* located at the beginning of this section.



Type "B" Single Stage Centrifugal Pump Electric Motor Drive

Section	CC
Page	180.6.1
Date	July 1, 2011
Supersedes 1/1/04	

SILICON BRONZE IMPELLERB3ZPL

Threaded Case (NPT)

Packing Construction

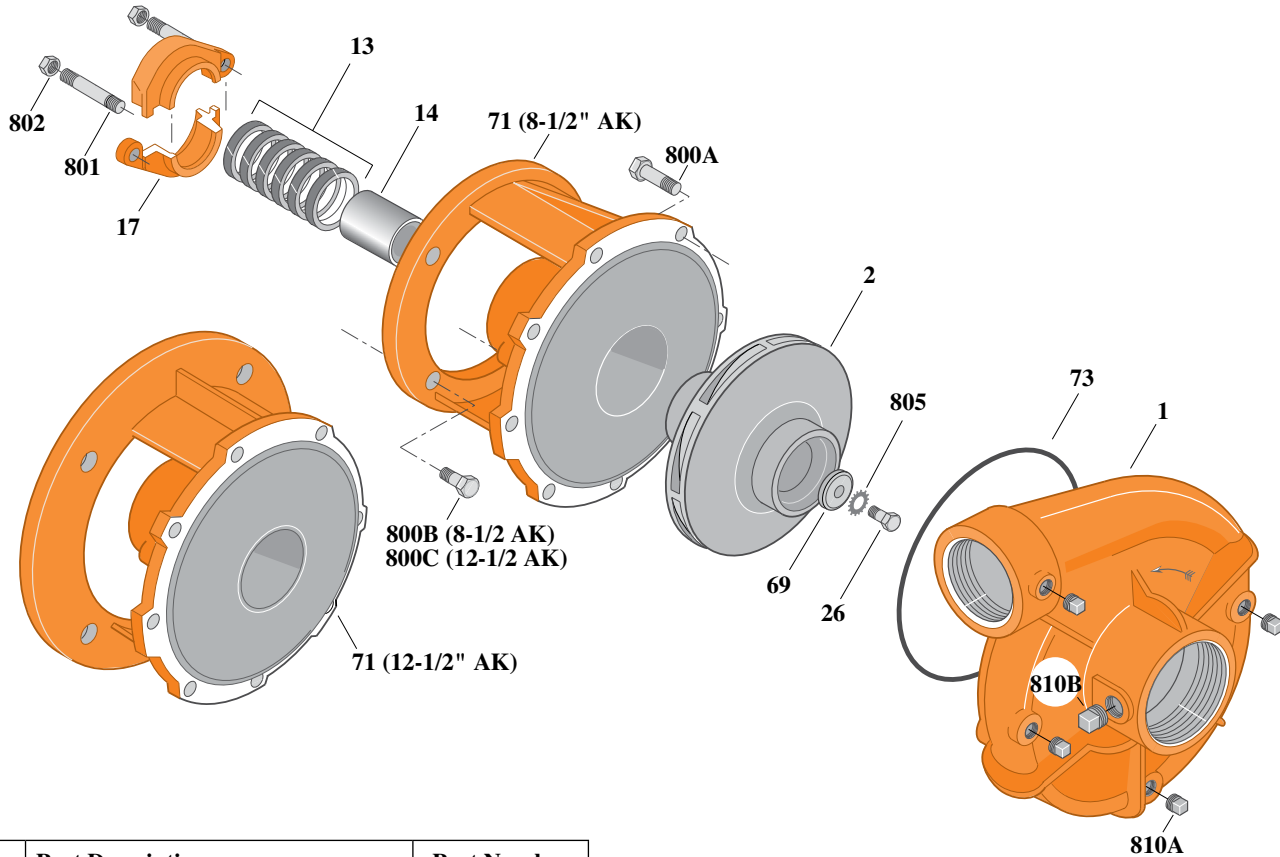

Item	Part Description	Part Number
1	Case, Volute	H00689
2	Impeller	See Table I
13	Rings, Packing (Set of 6)	S13470
14	Sleeve, Shaft	S05149L
17	Gland, Packing	B82470
26	Screw, Impeller 1/2 - 13 x 1-1/2"	S23623
32	Key, 1/4 x 2-1/4" (See Note 1)	S23677
69	Washer, Impeller	S06319
71	Bracket	See Table II
73	O-Ring (See Note 2)	M14943
800A	Capscrew, 3/8 - 16 x 1-1/8" (8 Req.)	S26827
800B	Capscrew, 1/2 - 13 x 1-1/2" (4 Req.)	S26916
800C	Capscrew, 5/8 - 11 x 1-1/2" (4 Req.)	S26999
801	Stud, 3/8 - 16 x 4" (2 Req.)	S08303
802	Nut, Hex 3/8 - 16 (2 Req.)	S23343
805	Washer, Lock	S23038
810A	Plug, Pipe 1/4 NPT (4 Req.)	S23715
810B	Plug, Pipe 1/2 NPT	S23717

Table I

B/M No.	HP	PH	RPM	"U" Dim.	Imp. Dia.	Imp. No.
B66674S	20	3	3600	1-1/4"	6.75"	H05484
B66688S	25	3	3600	1-1/4"	7.25"	H05485
B66694S	30	3	3600	1-1/4"	7.75"	H05486
B66700S	40	3	3600	1-1/4"	8.62"	H05487
B66845S	50	3	3600	1-1/4"	9.00"	H05488

Table II

HP	PH	Bracket No.	"AK" Fit	"U" Dim.	Motor Frame
20	3	L03827	8-1/2"	1-1/4"	254JP
25	3	L03827	8-1/2"	1-1/4"	256JP
30	3	L01563	12-1/2"	1-1/4"	284JP
40	3	L01563	12-1/2"	1-1/4"	286JP
50	3	L01563	12-1/2"	1-1/4"	324JP

NOTE 1: For an explanation of the tabulated material found on this page and for impeller key location, refer to *Supplement A* located at the beginning of this section.

NOTE 2: Also accepts gasket S05126 as replacement for o-ring. See *Supplement E* located at the beginning of this section.



Type "B" Single Stage Centrifugal Pump Electric Motor Drive

Section	CC
Page	180.6.2
Date	July 1, 2011
Supersedes 1/1/04	

SILICON BRONZE IMPELLERB3ZPL

Flanged Case

Packing Construction

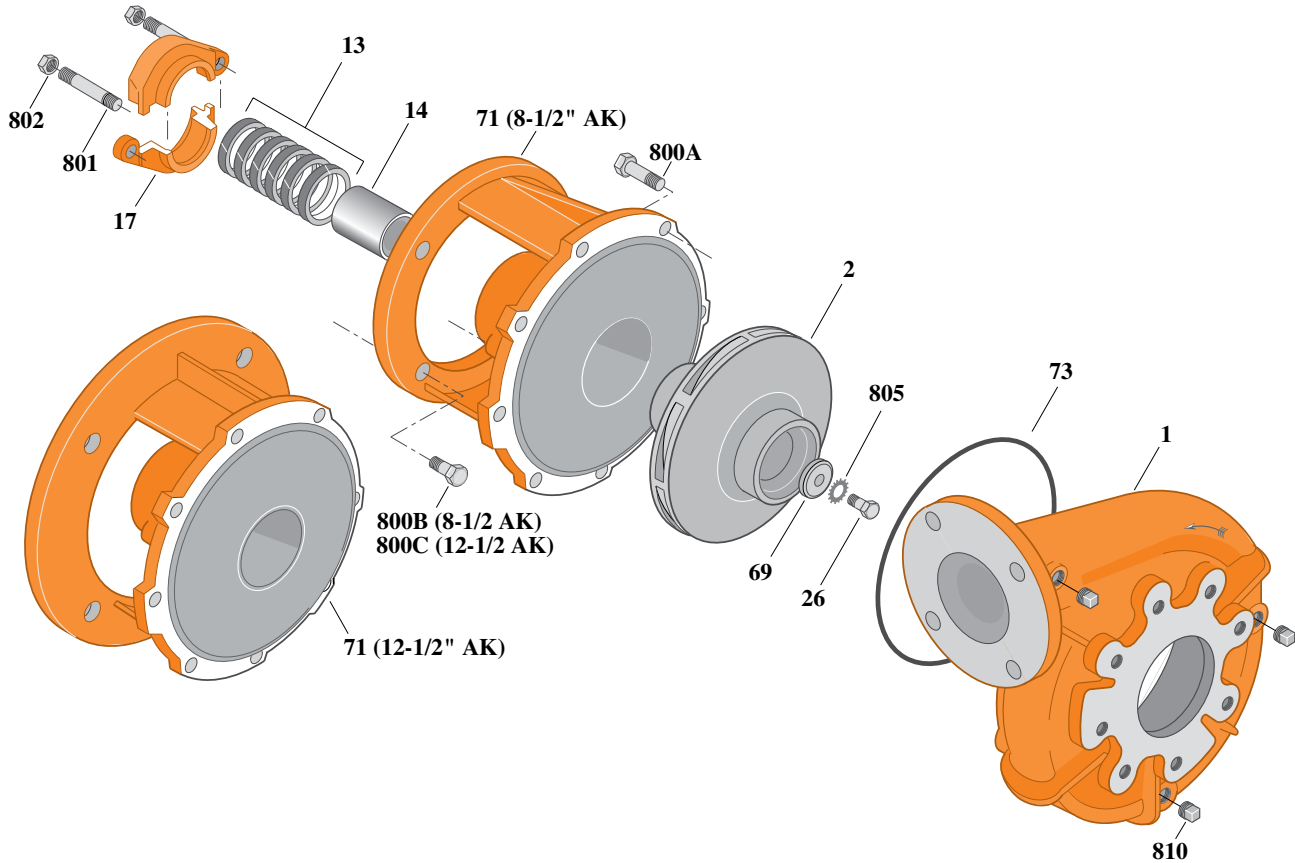

Item	Part Description	Part Number
1	Case, Volute	H05130
2	Impeller	See Table I
13	Rings, Packing (Set of 6)	S13470
14	Sleeve, Shaft	S05149L
17	Gland, Packing	B82470
26	Screw, Impeller 1/2 - 13 x 1-1/2"	S23623
32	Key, 1/4 x 2-1/4" (See Note 1)	S23677
69	Washer, Impeller	S06319
71	Bracket	See Table II
73	O-Ring (See Note 2)	M14943
800A	Capscrew, 3/8 - 16 x 1" (8 Req.)	S26826
800B	Capscrew, 1/2 - 13 x 1-1/2" (4 Req.)	S26916
800C	Capscrew, 5/8 - 11 x 1-1/2" (4 Req.)	S26999
801	Stud, 3/8 - 16 x 4" (2 Req.)	S08303
802	Nut, Hex 3/8 - 16 (2 Req.)	S23343
805	Washer, Lock	S23038
810	Plug, Pipe 1/4 NPT (3 Req.)	S23715

Table I

B/M No.	HP	PH	RPM	"U" Dim.	Imp. Dia.	Imp. No.
B70181S	20	3	3600	1-1/4"	6.75"	H05484
B70184S	25	3	3600	1-1/4"	7.25"	H05485
B70187S	30	3	3600	1-1/4"	7.75"	H05486
B70190S	40	3	3600	1-1/4"	8.62"	H05487
B70193S	50	3	3600	1-1/4"	9.00"	H05488

Table II

HP	PH	Bracket No.	"AK" Fit	"U" Dim.	Motor Frame
20	3	L03827	8-1/2"	1-1/4"	254JP
25	3	L03827	8-1/2"	1-1/4"	256JP
30	3	L01563	12-1/2"	1-1/4"	284JP
40	3	L01563	12-1/2"	1-1/4"	286JP
50	3	L01563	12-1/2"	1-1/4"	324JP

NOTE 1: For an explanation of the tabulated material found on this page and for impeller key location, refer to *Supplement A* located at the beginning of this section.

NOTE 2: Also accepts gasket S05126 as replacement for o-ring. See *Supplement E* located at the beginning of this section.



Type "B" Single Stage Centrifugal Pump Electric Motor Drive

Section	CC
Page	180.7
Date	July 1, 2011
Supersedes 1/1/04	

BRONZE IMPELLER

B3ZPLS

Threaded Case (NPT)

Mechanical Shaft Seal Construction

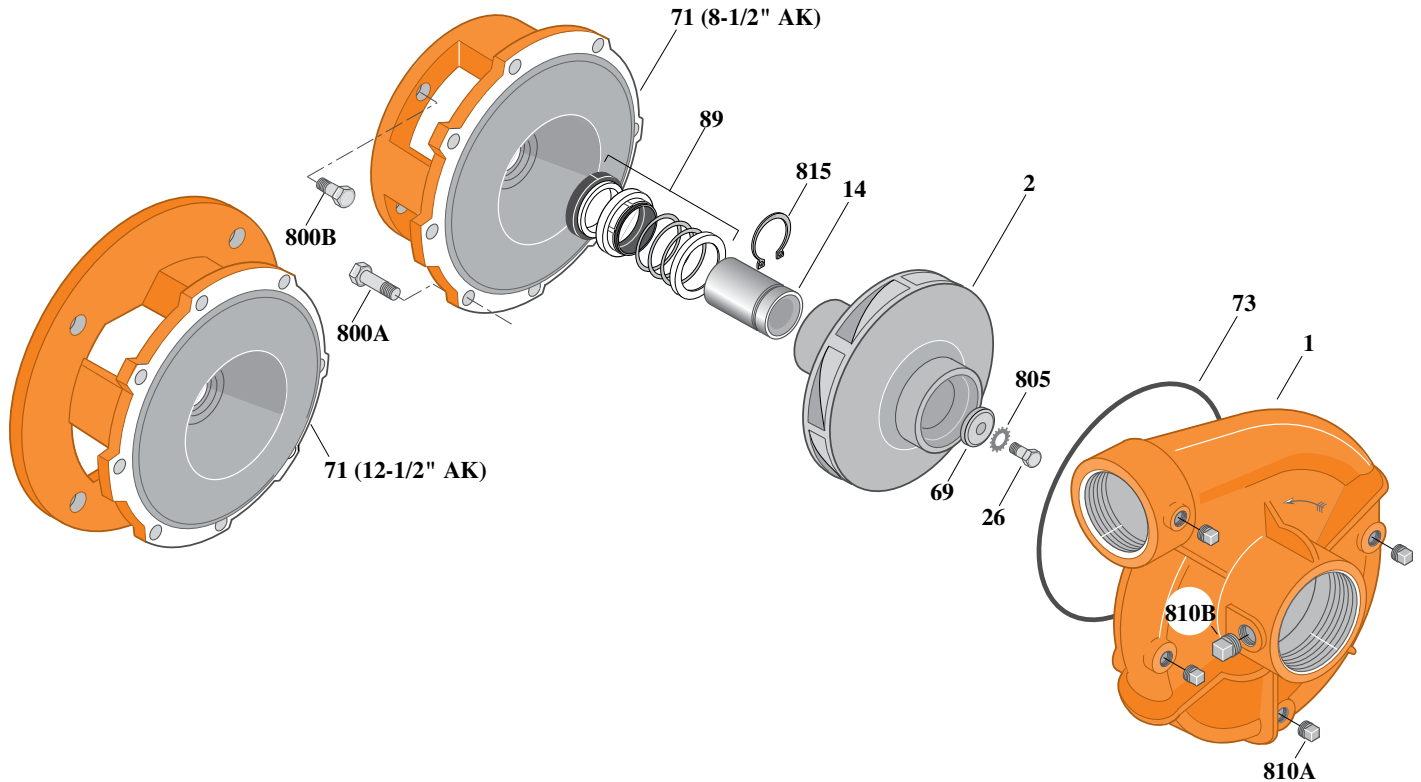

Item	Part Description	Part Number
1	Case, Volute	H00689
2	Impeller	See Table I
14	Sleeve, Shaft	S18869L
26	Screw, Impeller 1/2 - 13 x 1-1/2"	S23623
32	Key, 1/4 x 2-1/4" (See Note 1)	S23677
69	Washer, Impeller	S06319
71	Bracket	See Table II
73	O-Ring (See Note 2)	M14943
89	Seal, Mechanical Shaft	S32015
800A	Capscrew, 3/8 - 16 x 1" (8 Req.)	S26826
800B	Capscrew, 1/2 - 13 x 1" (4 Req.) (For 8-1/2 AK)	S26912
800B	Capscrew, 5/8 - 11 x 1-1/4" (4 Req.) (For 12-1/2 AK)	S26997
805	Washer, Lock	S23038
810A	Plug, Pipe 1/4 NPT (4 Req.)	S23715
810B	Plug, Pipe 1/2 NPT	S23717
815	Ring, Retaining	S16767

Table I

B/M No.	HP	PH	RPM	"U" Dim.	Imp. Dia.	Imp. No.
B66675						
B66689						
B66695						
B66701						
B66847						

These B/M Numbers
Are No Longer Available.

See Page 180.8.1 for Current Models.

Table II

HP	PH	Bracket No.	"AK" Fit	"U" Dim.	Motor Frame
20	3	L04615	8-1/2"	1-1/4"	254JM
25	3	L04615	8-1/2"	1-1/4"	256JM
30	3	L04627	12-1/2"	1-1/4"	284JM
40	3	L04627	12-1/2"	1-1/4"	286JM
50	3	L04627	12-1/2"	1-1/4"	324JM

NOTE 1: For an explanation of the tabulated material found on this page and for impeller key location, refer to **Supplement A** located at the beginning of this section.

NOTE 2: Also accepts gasket S05126 as replacement for o-ring. See **Supplement E** located at the beginning of this section.



Type "B" Single Stage Centrifugal Pump Electric Motor Drive

Section	CC
Page	180.8
Date	July 1, 2011
Supersedes 1/1/04	

BRONZE IMPELLERB3ZPLS

Flanged Case

Mechanical Shaft Seal Construction

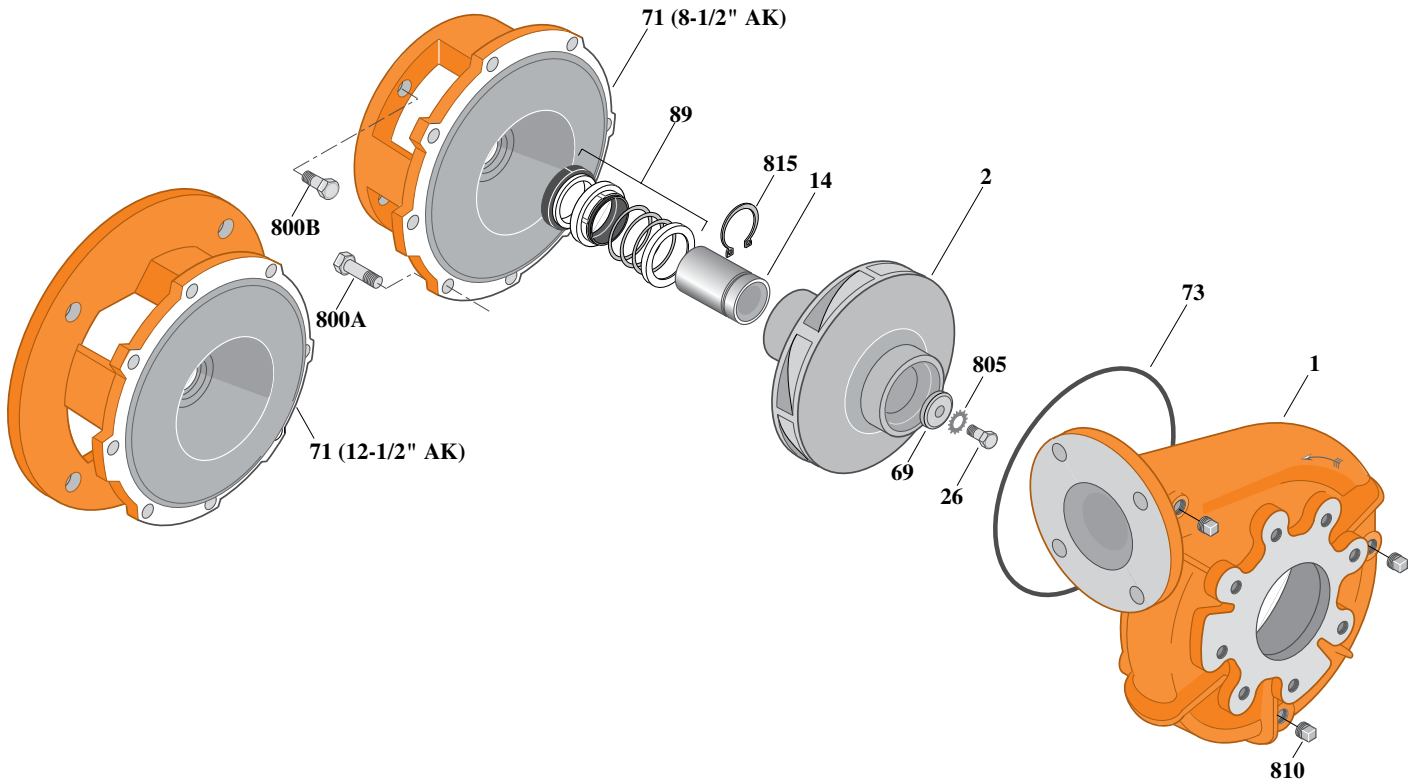

Table I

B/M No.	HP	PH	RPM	"U" Dim.	Imp. Dia.	Imp. No.
B70196	20	3	3600	1-1/4"	6.75"	L06598
B70198	25	3	3600	1-1/4"	7.25"	L06599
B70200	30	3	3600	1-1/4"	7.75"	L06600
B70202	40	3	3600	1-1/4"	8.62"	L06601
B70204	50	3	3600	1-1/4"	9.00"	L06659

Table II

HP	PH	Bracket No.	"AK" Fit	"U" Dim.	Motor Frame
20	3	L04615	8-1/2"	1-1/4"	254JM
25	3	L04615	8-1/2"	1-1/4"	256JM
30	3	L04627	12-1/2"	1-1/4"	284JM
40	3	L04627	12-1/2"	1-1/4"	286JM
50	3	L04627	12-1/2"	1-1/4"	324JM

NOTE 1: For an explanation of the tabulated material found on this page and for impeller key location, refer to **Supplement A** located at the beginning of this section.

NOTE 2: Also accepts gasket S05126 as replacement for o-ring. See **Supplement E** located at the beginning of this section.

Item	Part Description	Part Number
1	Case, Volute	H05130
2	Impeller	See Table I
14	Sleeve, Shaft	S18869L
26	Screw, Impeller 1/2 - 13 x 1-1/2"	S23623
32	Key, 1/4 x 2-1/4" (See Note 1)	S23677
69	Washer, Impeller	S06319
71	Bracket	See Table II
73	O-Ring (See Note 2)	M14943
89	Seal, Mechanical Shaft	S32015
800A	Capscrew, 3/8 - 16 x 1" (8 Req.)	S26826
800B	Capscrew, 1/2 - 13 x 1" (4 Req.) (For 8-1/2 AK)	S26912
800B	Capscrew, 5/8 - 11 x 1-1/4" (4 Req.) (For 12-1/2 AK)	S26997
805	Washer, Lock	S23038
810	Plug, Pipe 1/4 NPT (3 Req.)	S23715
815	Ring, Retaining	S16767



Type "B" Single Stage Centrifugal Pump Electric Motor Drive

Section	CC
Page	180.8.1
Date	July 1, 2011
Supersedes 1/1/04	

SILICON BRONZE IMPELLERB3ZPLS

Threaded Case (NPT)

Mechanical Shaft Seal Construction

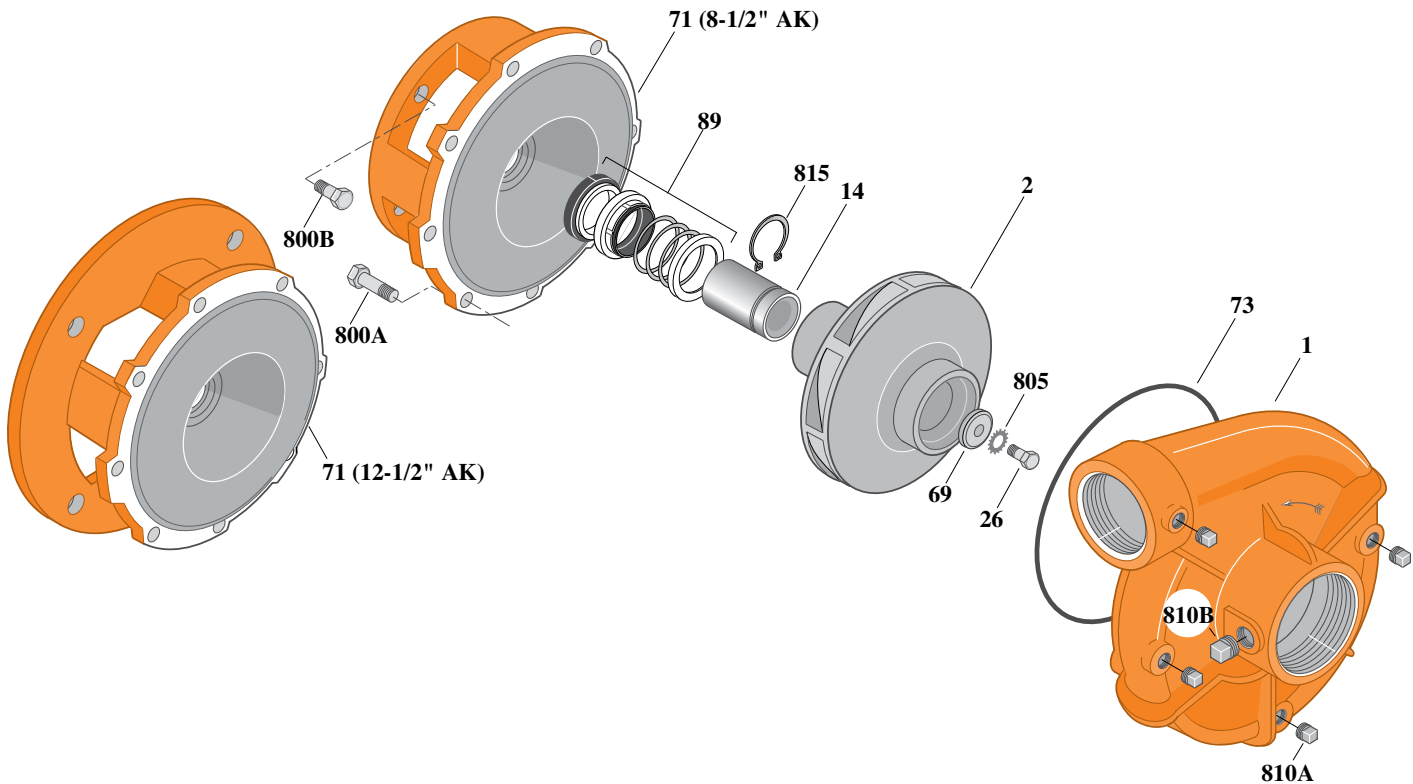

Item	Part Description	Part Number
1	Case, Volute	H00689
2	Impeller	See Table I
14	Sleeve, Shaft	S18869L
26	Screw, Impeller 1/2 - 13 x 1-1/2"	S23623
32	Key, 1/4 x 2-1/4" (See Note 1)	S23677
69	Washer, Impeller	S06319
71	Bracket	See Table II
73	O-Ring (See Note 2)	M14943
89	Seal, Mechanical Shaft	S32015
800A	Capscrew, 3/8 - 16 x 1" (8 Req.)	S26826
800B	Capscrew, 1/2 - 13 x 1" (4 Req.) (For 8-1/2 AK)	S26912
800B	Capscrew, 5/8 - 11 x 1-1/4" (4 Req.) (For 12-1/2 AK)	S26997
805	Washer, Lock	S23038
810A	Plug, Pipe 1/4 NPT (4 Req.)	S23715
810B	Plug, Pipe 1/2 NPT	S23717
815	Ring, Retaining	S16767

Table I

B/M No.	HP	PH	RPM	"U" Dim.	Imp. Dia.	Imp. No.
B66675S	20	3	3600	1-1/4"	6.75"	H05484
B66689S	25	3	3600	1-1/4"	7.25"	H05485
B66695S	30	3	3600	1-1/4"	7.75"	H05486
B66701S	40	3	3600	1-1/4"	8.62"	H05487
B66847S	50	3	3600	1-1/4"	9.00"	H05488

Table II

HP	PH	Bracket No.	"AK" Fit	"U" Dim.	Motor Frame
20	3	L04615	8-1/2"	1-1/4"	254JM
25	3	L04615	8-1/2"	1-1/4"	256JM
30	3	L04627	12-1/2"	1-1/4"	284JM
40	3	L04627	12-1/2"	1-1/4"	286JM
50	3	L04627	12-1/2"	1-1/4"	324JM

NOTE 1: For an explanation of the tabulated material found on this page and for impeller key location, refer to **Supplement A** located at the beginning of this section.

NOTE 2: Also accepts gasket S05126 as replacement for o-ring. See **Supplement E** located at the beginning of this section.



Type "B" Single Stage Centrifugal Pump Electric Motor Drive

Section	CC
Page	180.8.2
Date	July 1, 2011
Supersedes 1/1/04	

SILICON BRONZE IMPELLERB3ZPLS

Flanged Case

Mechanical Shaft Seal Construction

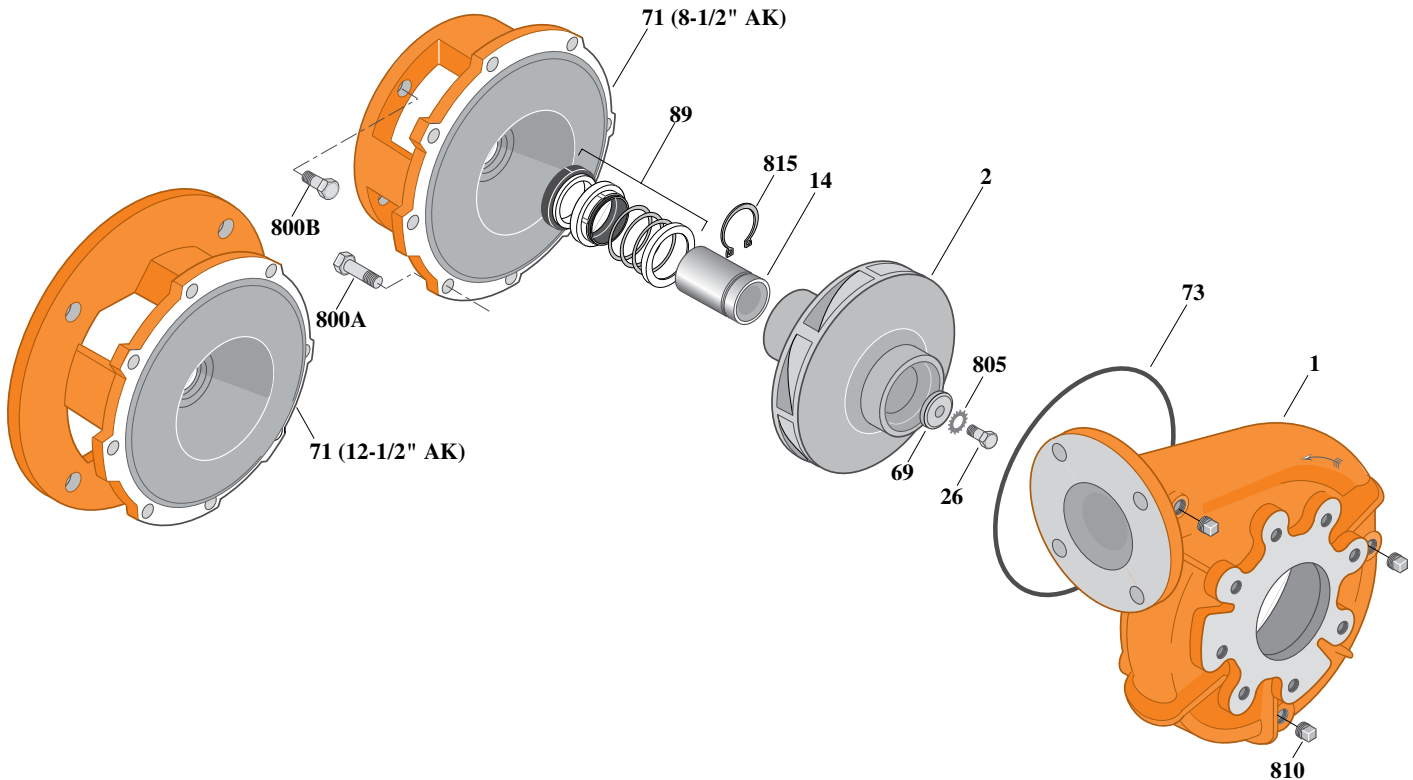

Table I

B/M No.	HP	PH	RPM	"U" Dim.	Imp. Dia.	Imp. No.
B70196S	20	3	3600	1-1/4"	6.75"	H05484
B70198S	25	3	3600	1-1/4"	7.25"	H05485
B70200S	30	3	3600	1-1/4"	7.75"	H05486
B70202S	40	3	3600	1-1/4"	8.62"	H05487
B70204S	50	3	3600	1-1/4"	9.00"	H05488

Table II

HP	PH	Bracket No.	"AK" Fit	"U" Dim.	Motor Frame
20	3	L04615	8-1/2"	1-1/4"	254JM
25	3	L04615	8-1/2"	1-1/4"	256JM
30	3	L04627	12-1/2"	1-1/4"	284JM
40	3	L04627	12-1/2"	1-1/4"	286JM
50	3	L04627	12-1/2"	1-1/4"	324JM

NOTE 1: For an explanation of the tabulated material found on this page and for impeller key location, refer to *Supplement A* located at the beginning of this section.

NOTE 2: Also accepts gasket S05126 as replacement for o-ring. See *Supplement E* located at the beginning of this section.

Item	Part Description	Part Number
1	Case, Volute	H05130
2	Impeller	See Table I
14	Sleeve, Shaft	S18869L
26	Screw, Impeller 1/2 - 13 x 1-1/2"	S23623
32	Key, 1/4 x 2-1/4" (See Note 1)	S23677
69	Washer, Impeller	S06319
71	Bracket	See Table II
73	O-Ring (See Note 2)	M14943
89	Seal, Mechanical Shaft	S32015
800A	Capscrew, 3/8 - 16 x 1" (8 Req.)	S26826
800B	Capscrew, 1/2 - 13 x 1" (4 Req.) (For 8-1/2 AK)	S26912
800B	Capscrew, 5/8 - 11 x 1-1/4" (4 Req.) (For 12-1/2 AK)	S26997
805	Washer, Lock	S23038
810	Plug, Pipe 1/4 NPT (3 Req.)	S23715
815	Ring, Retaining	S16767



Type "B" Single Stage Centrifugal Pump Electric Motor Drive

Section	CC
Page	180.9
Date	July 1, 2011
Supersedes 1/1/04	

SILICON BRONZE IMPELLER

B3ZPL

Threaded Case (NPT)

Packing Construction

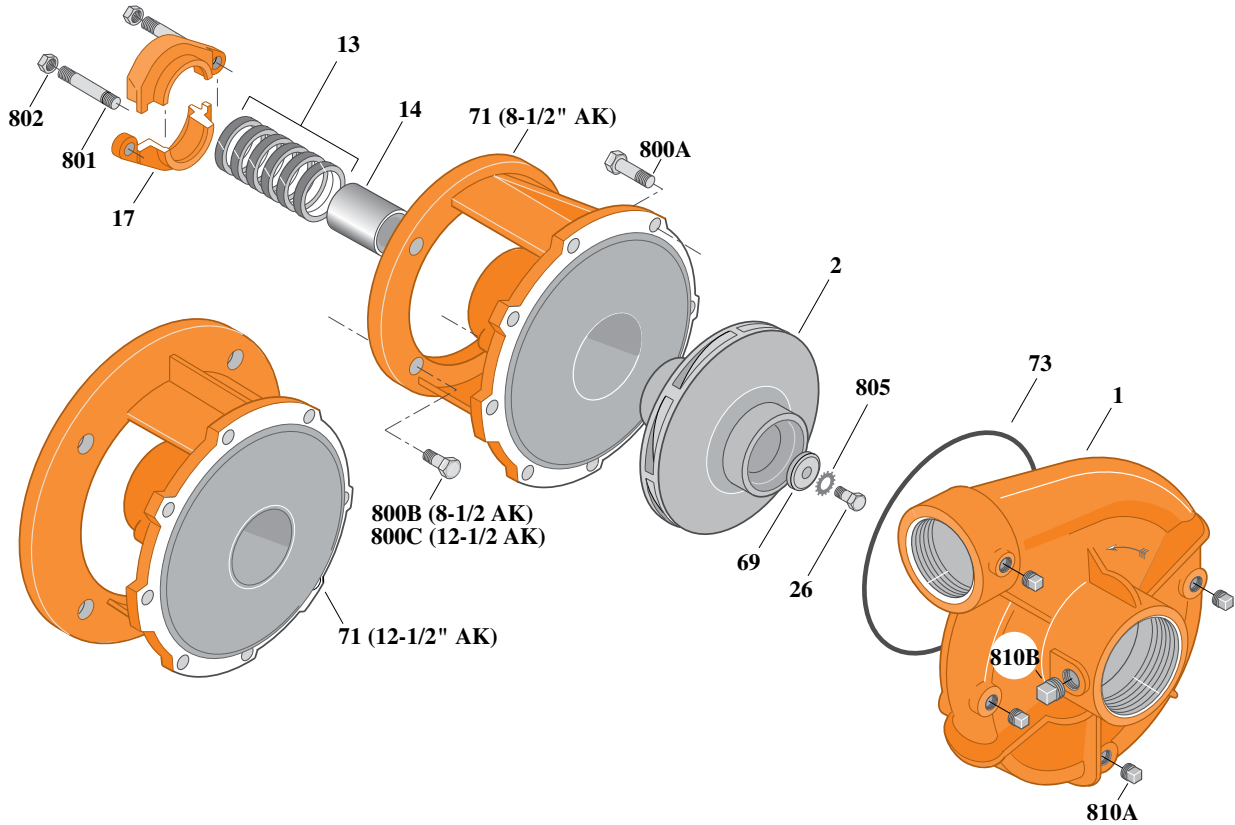

Item	Part Description	Part Number
1	Case, Volute	H00689
2	Impeller	See Table I
13	Rings, Packing (Set of 6)	S13470
14	Sleeve, Shaft	S05149L
17	Gland, Packing	B82470
26	Screw, Impeller 1/2 - 13 x 1-1/2"	S23623
32	Key, 1/4 x 2-1/4" (See Note 1)	S23677
69	Washer, Impeller	S06319
71	Bracket	See Table II
73	O-Ring (See Note 2)	M14943
800A	Capscrew, 3/8 - 16 x 1" (8 Req.)	S26826
800B	Capscrew, 1/2 - 13 x 1-1/2" (4 Req.)	S26916
800C	Capscrew, 5/8 - 11 x 1-1/2" (4 Req.)	S26999
801	Stud, 3/8 - 16 x 4" (2 Req.)	S08303
802	Nut, Hex 3/8 - 16 (2 Req.)	S23343
805	Washer, Lock	S23038
810A	Plug, Pipe 1/4" NPT (4 Req.)	S23715
810B	Plug, Pipe 1/2" NPT	S23717

Table I

B/M No.	HP	PH	RPM	"U" Dim.	Imp. Dia.	Imp. No.
B66674S	20	3	3600	1-1/4"	6.75"	H05484
B66688S	25	3	3600	1-1/4"	7.25"	H05485
B66694S	30	3	3600	1-1/4"	7.75"	H05486
B66700S	40	3	3600	1-1/4"	8.62"	H05487
B66845S	50	3	3600	1-1/4"	9.00"	H05488

Table II

HP	PH	Bracket No.	"AK" Fit	"U" Dim.	Motor Frame
20	3	L03827	8-1/2"	1-1/4"	254JP
25	3	L03827	8-1/2"	1-1/4"	256JP
30	3	L01563	12-1/2"	1-1/4"	284JP
40	3	L01563	12-1/2"	1-1/4"	286JP
50	3	L01563	12-1/2"	1-1/4"	324JP

NOTE 1: For an explanation of the tabulated material found on this page and for impeller key location, refer to *Supplement A* located at the beginning of this section.

NOTE 2: Also accepts gasket S05126 as replacement for o-ring. See *Supplement E* located at the beginning of this section.



Type "B" Single Stage Centrifugal Pump Electric Motor Drive

Section	CC
Page	180.10
Date	July 1, 2011
Supersedes 1/1/04	

SILICON BRONZE IMPELLERB3ZPL

Flanged Case

Packing Construction

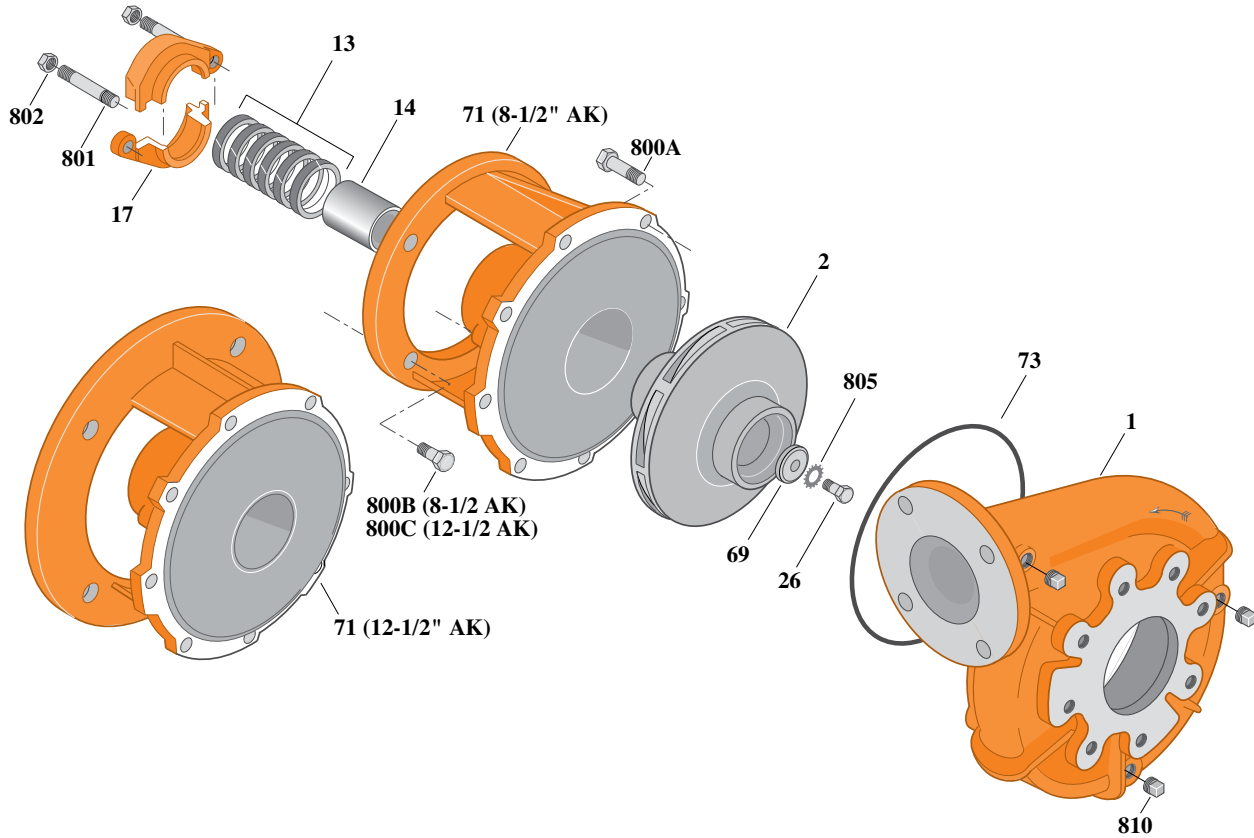

Table I

B/M No.	HP	PH	RPM	"U" Dim.	Imp. Dia.	Imp. No.
B70181S	20	3	3600	1-1/4"	6.75"	H05484
B70184S	25	3	3600	1-1/4"	7.25"	H05485
B70187S	30	3	3600	1-1/4"	7.75"	H05486
B70190S	40	3	3600	1-1/4"	8.62"	H05487
B70193S	50	3	3600	1-1/4"	9.00"	H05488

Table II

HP	PH	Bracket No.	"AK" Fit	"U" Dim.	Motor Frame
20	3	L03827	8-1/2"	1-1/4"	254JP
25	3	L03827	8-1/2"	1-1/4"	256JP
30	3	L01563	12-1/2"	1-1/4"	284JP
40	3	L01563	12-1/2"	1-1/4"	286JP
50	3	L01563	12-1/2"	1-1/4"	324JP

Item	Part Description	Part Number
1	Case, Volute	H05130
2	Impeller	See Table I
13	Rings, Packing (Set of 6)	S13470
14	Sleeve, Shaft	S05149L
17	Gland, Packing	B82470
26	Screw, Impeller 1/2 - 13 x 1-1/2"	S23623
32	Key, 1/4 x 2-1/4" (See Note 1)	S23677
69	Washer, Impeller	S06319
71	Bracket	See Table II
73	O-Ring (See Note 2)	M14943
800A	Capscrew, 3/8 - 16 x 1" (8 Req.)	S26826
800B	Capscrew, 1/2 - 13 x 1-1/2" (4 Req.)	S26916
800C	Capscrew, 5/8 - 11 x 1-1/2" (4 Req.)	S26999
801	Stud, 3/8 - 16 x 4" (2 Req.)	S08303
802	Nut, Hex 3/8 - 16 (2 Req.)	S23343
805	Washer, Lock	S23038
810	Plug, Pipe 1/4" NPT (3 Req.)	S23715

NOTE 1: For an explanation of the tabulated material found on this page and for impeller key location, refer to *Supplement A* located at the beginning of this section.

NOTE 2: Also accepts gasket S05126 as replacement for o-ring. See *Supplement E* located at the beginning of this section.



Type "B" Single Stage Centrifugal Pump Electric Motor Drive

Section	CC
Page	180.11
Date	July 1, 2011
Supersedes 1/1/04	

SILICON BRONZE IMPELLER

B3ZPLS

Threaded Case (NPT)

Mechanical Shaft Seal Construction

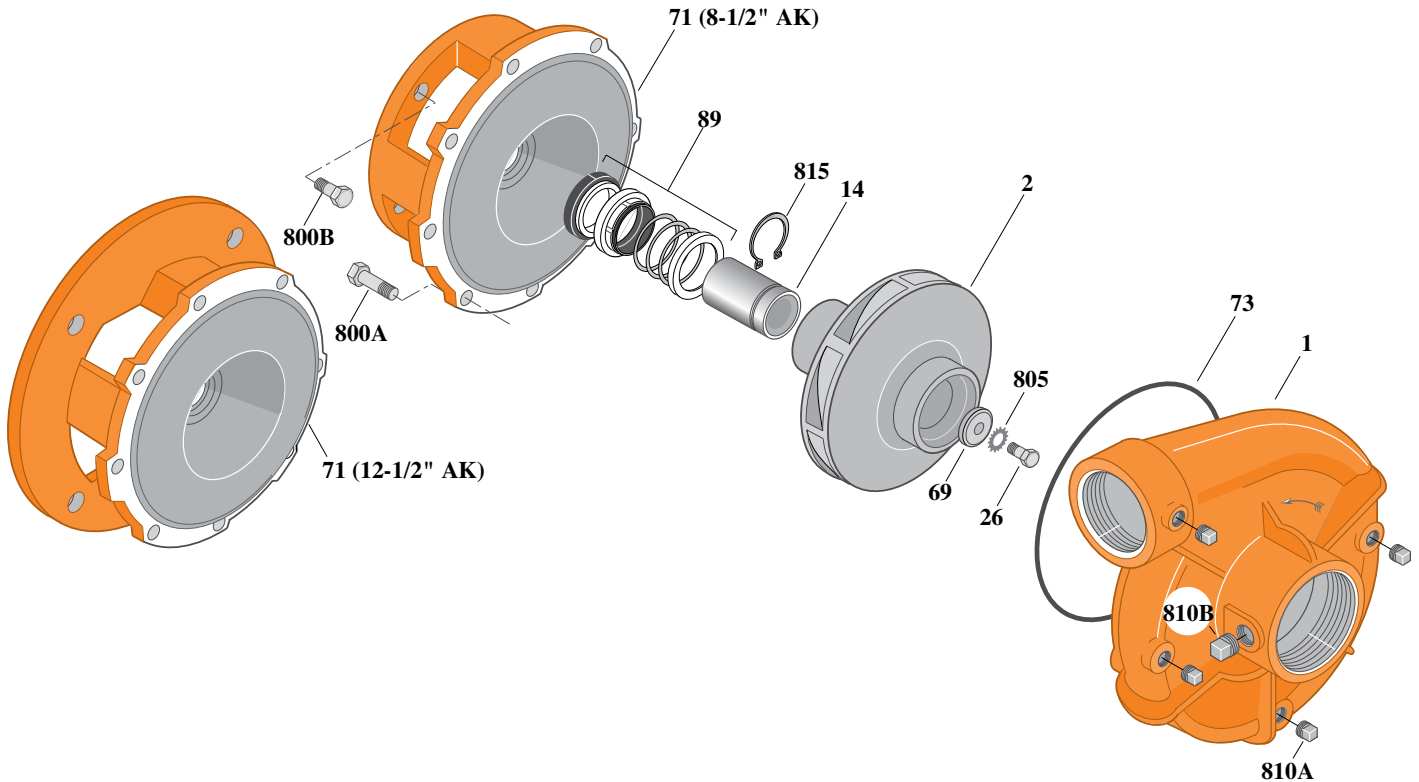

Item	Part Description	Part Number
1	Case, Volute	H00689
2	Impeller	See Table I
14	Sleeve, Shaft	S18869L
26	Screw, Impeller 1/2 - 13 x 1-1/2"	S23623
32	Key, 1/4 x 2-1/4" (See Note 1)	S23677
69	Washer, Impeller	S06319
71	Bracket	See Table II
73	O-Ring (See Note 3)	M14943
89	Seal, Mechanical Shaft	S32015
800A	Capscrew, 3/8 - 16 x 1" (8 Req.)	S26826
800B	Capscrew, 1/2 - 13 x 1" (4 Req.) (For 8-1/2 AK)	S26912
800B	Capscrew, 5/8 - 11 x 1-1/4" (4 Req.) (For 12-1/2 AK)	S26997
805	Washer, Lock	S23038
810A	Plug, Pipe 1/4" NPT (4 Req.)	S23715
810B	Plug, Pipe 1/2" NPT	S23717
815	Ring, Retaining	S16767
•	Plug, Pipe 1/8" NPT (In Bracket)	S23714

• Not illustrated.

Table I

B/M No.	HP	PH	RPM	"U" Dim.	Imp. Dia.	Imp. No.
B66675S	20	3	3600	1-1/4"	6.75"	H05484
B66689S	25	3	3600	1-1/4"	7.25"	H05485
B66695S	30	3	3600	1-1/4"	7.75"	H05486
B66701S	40	3	3600	1-1/4"	8.62"	H05487
B66847S	50	3	3600	1-1/4"	9.00"	H05488

Table II

HP	PH	Bracket No.	"AK" Fit	"U" Dim.	Motor Frame
20	3	L04615	8-1/2"	1-1/4"	254JM
25	3	L04615	8-1/2"	1-1/4"	256JM
30	3	L04627	12-1/2"	1-1/4"	284JM
40	3	L04627	12-1/2"	1-1/4"	286JM
50	3	L04627	12-1/2"	1-1/4"	324JM

NOTE 1: For an explanation of the tabulated material found on this page and for impeller key location, refer to *Supplement A* located at the beginning of this section.

NOTE 2: For seal flush line details, see *Supplement D*.

NOTE 3: Also accepts gasket S05126 as replacement for o-ring. See *Supplement E* located at the beginning of this section.



Type "B" Single Stage Centrifugal Pump Electric Motor Drive

Section	CC
Page	180.12
Date	July 1, 2011
Supersedes 1/1/04	

SILICON BRONZE IMPELLERB3ZPLS

Flanged Case

Mechanical Shaft Seal Construction

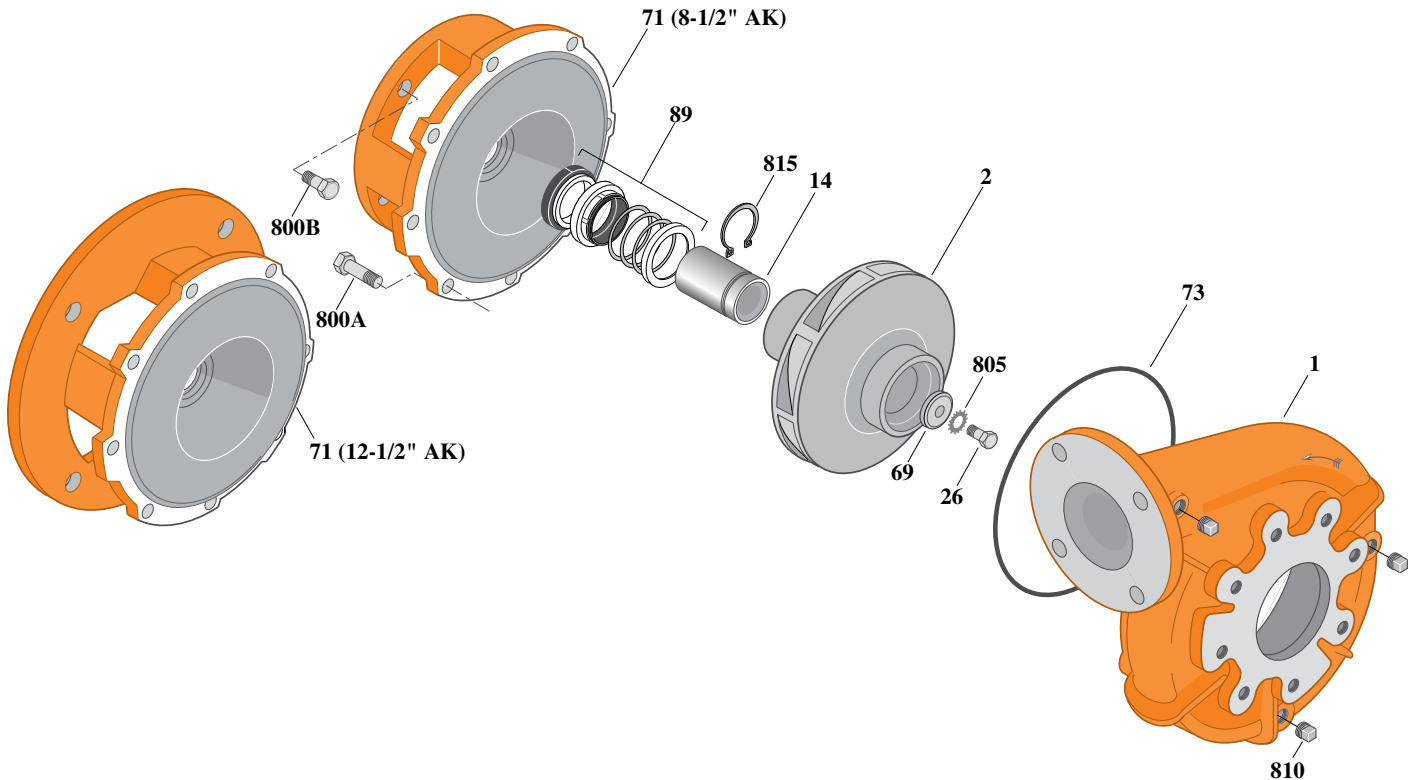

Item	Part Description	Part Number
1	Case, Volute	H05130
2	Impeller	See Table I
14	Sleeve, Shaft	S18869L
26	Screw, Impeller 1/2 - 13 x 1-1/2"	S23623
32	Key, 1/4 x 2-1/4" (See Note 1)	S23677
69	Washer, Impeller	S06319
71	Bracket	See Table II
73	O-Ring (See Note 3)	M14943
89	Seal, Mechanical Shaft	S32015
800A	Capscrew, 3/8 - 16 x 1" (8 Req.)	S26826
800B	Capscrew, 1/2 - 13 x 1" (4 Req.) For 8-1/2 AK	S26912
800B	Capscrew, 5/8 - 11 x 1-1/4" (4 Req.) (For 12-1/2 AK)	S26997
805	Washer, Lock	S23038
810	Plug, Pipe 1/4" NPT (3 Req.)	S23715
815	Ring, Retaining	S16767
•	Plug, Pipe 1/8" NPT (In Bracket)	S23714

• Not illustrated.

Table I

B/M No.	HP	PH	RPM	"U" Dim.	Imp. Dia.	Imp. No.
B70196S	20	3	3600	1-1/4"	6.75"	H05484
B70198S	25	3	3600	1-1/4"	7.25"	H05485
B70200S	30	3	3600	1-1/4"	7.75"	H05486
B70202S	40	3	3600	1-1/4"	8.62"	H05487
B70204S	50	3	3600	1-1/4"	9.00"	H05488

Table II

HP	PH	Bracket No.	"AK" Fit	"U" Dim.	Motor Frame
20	3	L04615	8-1/2"	1-1/4"	254JM
25	3	L04615	8-1/2"	1-1/4"	256JM
30	3	L04627	12-1/2"	1-1/4"	284JM
40	3	L04627	12-1/2"	1-1/4"	286JM
50	3	L04627	12-1/2"	1-1/4"	324JM

NOTE 1: For an explanation of the tabulated material found on this page and for impeller key location, refer to *Supplement A* located at the beginning of this section.

NOTE 2: For seal flush line details, see *Supplement D*.

NOTE 3: Also accepts gasket S05126 as replacement for o-ring. See *Supplement E* located at the beginning of this section.