



TYPE "B" SINGLE STAGE CENTRIFUGAL PUMP Electric Motor Drive

| | |
|-------------------|-----------------|
| Section | CC |
| Page | 240.1 |
| Date | January 1, 2004 |
| Supersedes 6/1/95 | |

CAST IRON IMPELLER

B3JPBM

Threaded Case (NPT)

Packing Construction

TABLE I

| B/M No. | HP | PH | RPM | "U" Dim. | Imp. Dia. | Imp. No. |
|---------|----|----|------|----------|-----------|----------|
| B51721 | 15 | 3 | 1800 | 1-1/4" | 10.18" | L06176 |
| B51722 | 20 | 3 | 1800 | 1-1/4" | 11.12" | L06177 |
| B53835 | 25 | 3 | 1800 | 1-1/4" | 11.81" | L06178 |
| B53836 | 30 | 3 | 1800 | 1-1/4" | 12.44" | L06179 |
| B51725 | 40 | 3 | 1800 | 1-1/4" | 13.50" | L03001 |

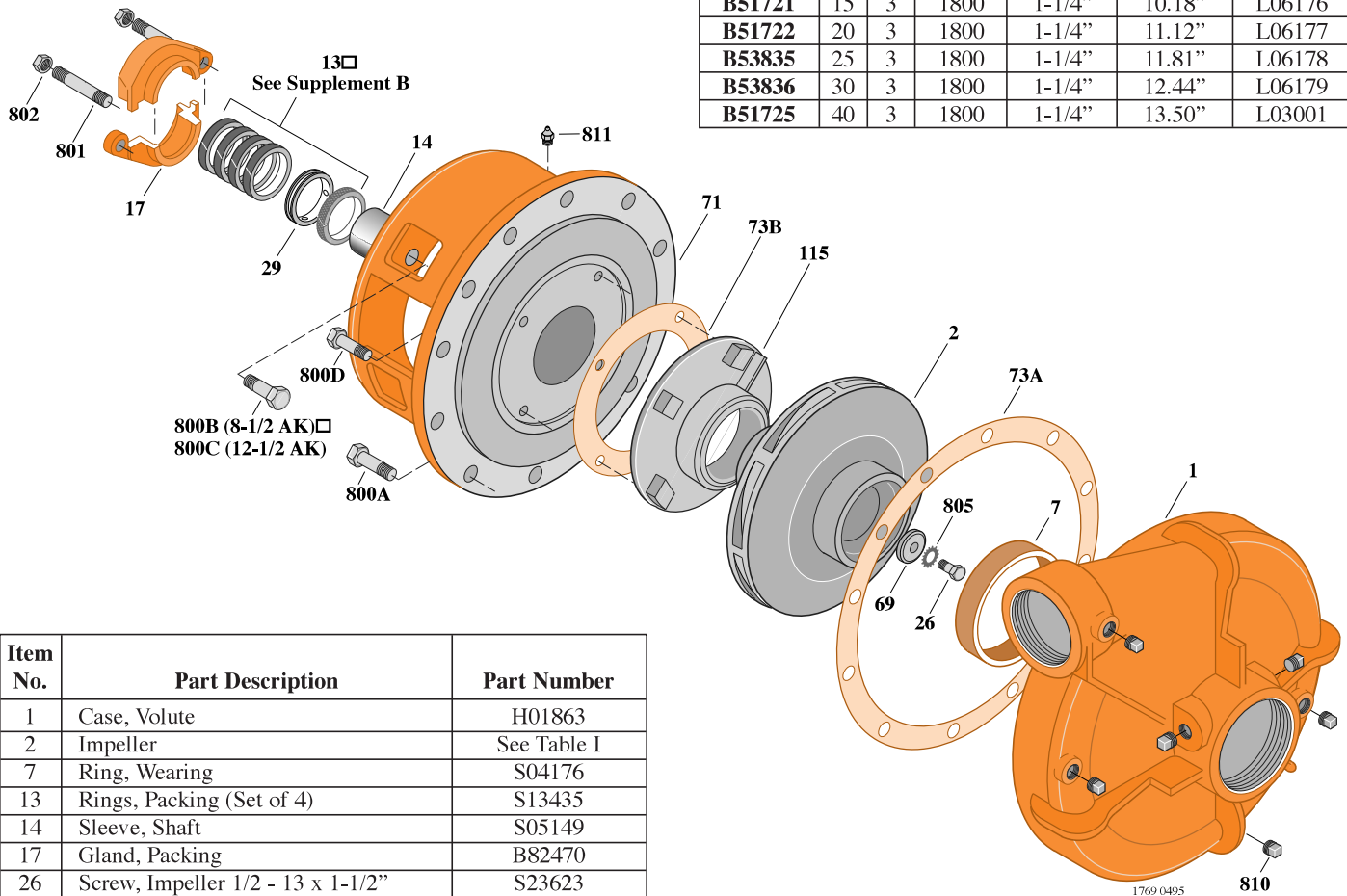

| Item No. | Part Description | Part Number |
|----------|---------------------------------------|--------------|
| 1 | Case, Volute | H01863 |
| 2 | Impeller | See Table I |
| 7 | Ring, Wearing | S04176 |
| 13 | Rings, Packing (Set of 4) | S13435 |
| 14 | Sleeve, Shaft | S05149 |
| 17 | Gland, Packing | B82470 |
| 26 | Screw, Impeller 1/2 - 13 x 1-1/2" | S23623 |
| 29 | Ring, Lantern | S19200 |
| 32 | Key, 1/4 x 2-1/4" (See Note) | S23677 |
| 69 | Washer, Impeller | S06319 |
| 71 | Bracket | See Table II |
| 73A | Gasket, Volute | S06271 |
| 73B | Gasket, Balance Ring | S09943 |
| 115 | Ring, Balance | M05115 |
| 800A | Capscrew, 5/8 - 11 x 1-1/2" (12 Req.) | S26999 |
| 800B | Capscrew, 1/2 - 13 x 1-1/2" (4 Req.) | S26916 |
| 800C | Capscrew, 3/8 - 16 x 1-1/2" (4 Req.) | S26830 |
| 801 | Stud, 3/8 - 16 x 2-1/2" (2 Req.) | S04438 |
| 802 | Nut, Hex 3/8 - 16 (2 Req.) | S23343 |
| 805 | Washer, Lock | S23038 |
| 810 | Plug, Pipe 1/2 NPT (6 Req.) | S23717 |
| 811 | Fitting, Grease | S23700 |
| 812 | Elbow, Street | S25421 |

TABLE II

| HP | PH | Bracket No. | "AK" Fit | "U" Dim. | Motor Frame |
|----|----|-------------|----------|----------|-------------|
| 15 | 3 | H02384 | 8-1/2" | 1-1/4" | 254JP |
| 20 | 3 | H02384 | 8-1/2" | 1-1/4" | 256JP |
| 25 | 3 | H01601 | 12-1/2" | 1-1/4" | 284JP |
| 30 | 3 | H01601 | 12-1/2" | 1-1/4" | 286JP |
| 40 | 3 | H01601 | 12-1/2" | 1-1/4" | 324JP |

NOTE: For an explanation of the tabulated material found on this page and for impeller key location, refer to *Supplement A* located at the beginning of this section.



TYPE "B" SINGLE STAGE CENTRIFUGAL PUMP Electric Motor Drive

| | |
|-------------------|-----------------|
| Section | CC |
| Page | 240.2 |
| Date | January 1, 2004 |
| Supersedes 6/1/95 | |

CAST IRON IMPELLER B3JPBMS

Threaded Case (NPT)

Mechanical Shaft Seal Construction

TABLE I

| B/M No. | HP | PH | RPM | "U" Dim. | Imp. Dia. | Imp. No. |
|---------|----|----|------|----------|-----------|----------|
| B54140 | 15 | 3 | 1800 | 1-1/4" | 10.18" | L06176 |
| B54141 | 20 | 3 | 1800 | 1-1/4" | 11.12" | L06177 |
| B54142 | 25 | 3 | 1800 | 1-1/4" | 11.81" | L06178 |
| B54143 | 30 | 3 | 1800 | 1-1/4" | 12.44" | L06179 |
| B54144 | 40 | 3 | 1800 | 1-1/4" | 13.50" | L03001 |

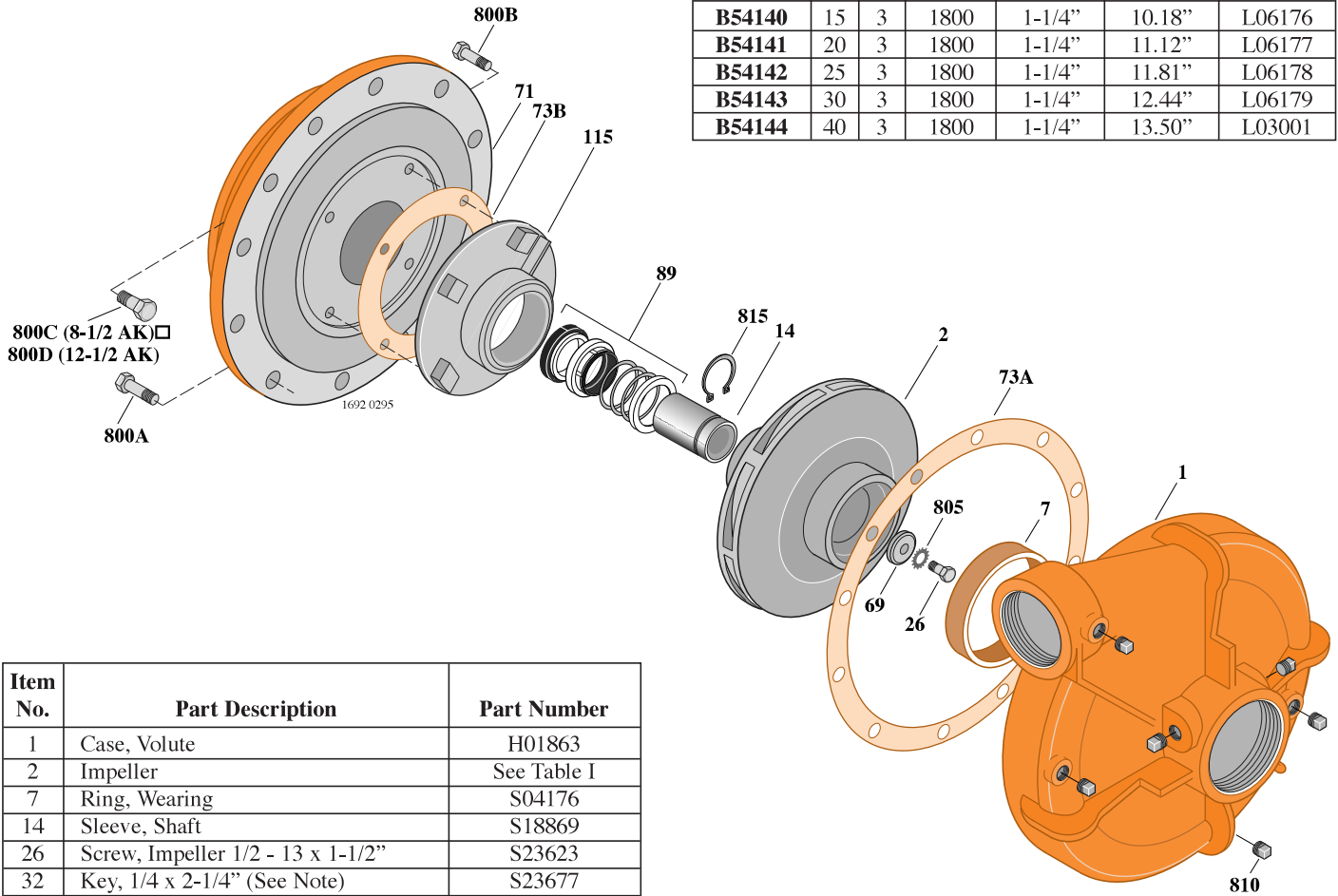

| Item No. | Part Description | Part Number |
|----------|--|--------------|
| 1 | Case, Volute | H01863 |
| 2 | Impeller | See Table I |
| 7 | Ring, Wearing | S04176 |
| 14 | Sleeve, Shaft | S18869 |
| 26 | Screw, Impeller 1/2 - 13 x 1-1/2" | S23623 |
| 32 | Key, 1/4 x 2-1/4" (See Note) | S23677 |
| 69 | Washer, Impeller | S06319 |
| 71 | Bracket | See Table II |
| 73A | Gasket, Volute Case | S06271 |
| 73B | Gasket, Balance Ring | S09943 |
| 79 | Seal, Mechanical Shaft | S32015 |
| 115 | Ring, Balance | M06646 |
| 800A | Capscrew, 5/8 - 11 x 1-1/2" (12 Req.) (8-1/2 AK) | S26999 |
| 800A | Capscrew, 5/8 - 11 x 1-1/2" (16 Req.) (12-1/2 AK) | S26999 |
| 800B | Capscrew, 1/2 - 13 x 1-1/2" (4 Req.) (8-1/2 AK Only) | S26916 |
| 800C | Capscrew, 3/8 - 16 x 1" (4 Req.) | S26826 |
| 805 | Washer, Lock | S23038 |
| 810 | Plug, Pipe 1/2 NPT (6 Req.) | S23717 |
| 815 | Ring, Retaining | S16767 |

TABLE II

| HP | PH | Bracket No. | "AK" Fit | "U" Dim. | Motor Frame |
|----|----|-------------|----------|----------|-------------|
| 15 | 3 | H03300 | 8-1/2" | 1-1/4" | 254JM |
| 20 | 3 | H03300 | 8-1/2" | 1-1/4" | 256JM |
| 25 | 3 | H03301 | 12-1/2" | 1-1/4" | 284JM |
| 30 | 3 | H03301 | 12-1/2" | 1-1/4" | 286JM |
| 40 | 3 | H03301 | 12-1/2" | 1-1/4" | 324JM |

NOTE: For an explanation of the tabulated material found on this page and for impeller key location, refer to *Supplement A* located at the beginning of this section.



TYPE "B" SINGLE STAGE CENTRIFUGAL PUMP Electric Motor Drive

| | |
|-------------------|-----------------|
| Section | CC |
| Page | 240.3 |
| Date | January 1, 2004 |
| Supersedes 9/1/97 | |

SILICON BRONZE IMPELLER

B3JPBM

Threaded Case (NPT)

Packing Construction

TABLE I

| B/M No. | HP | PH | RPM | "U" Dim. | Imp. Dia. | Imp. No. |
|---------------|----|----|------|----------|-----------|----------|
| B74696 | 15 | 3 | 1800 | 1-1/4" | 10.18" | H05659 |
| B74700 | 20 | 3 | 1800 | 1-1/4" | 11.12" | H05660 |
| B74704 | 25 | 3 | 1800 | 1-1/4" | 11.81" | H05678 |
| B74708 | 30 | 3 | 1800 | 1-1/4" | 12.44" | H05661 |
| B74712 | 40 | 3 | 1800 | 1-1/4" | 13.50" | H05662 |

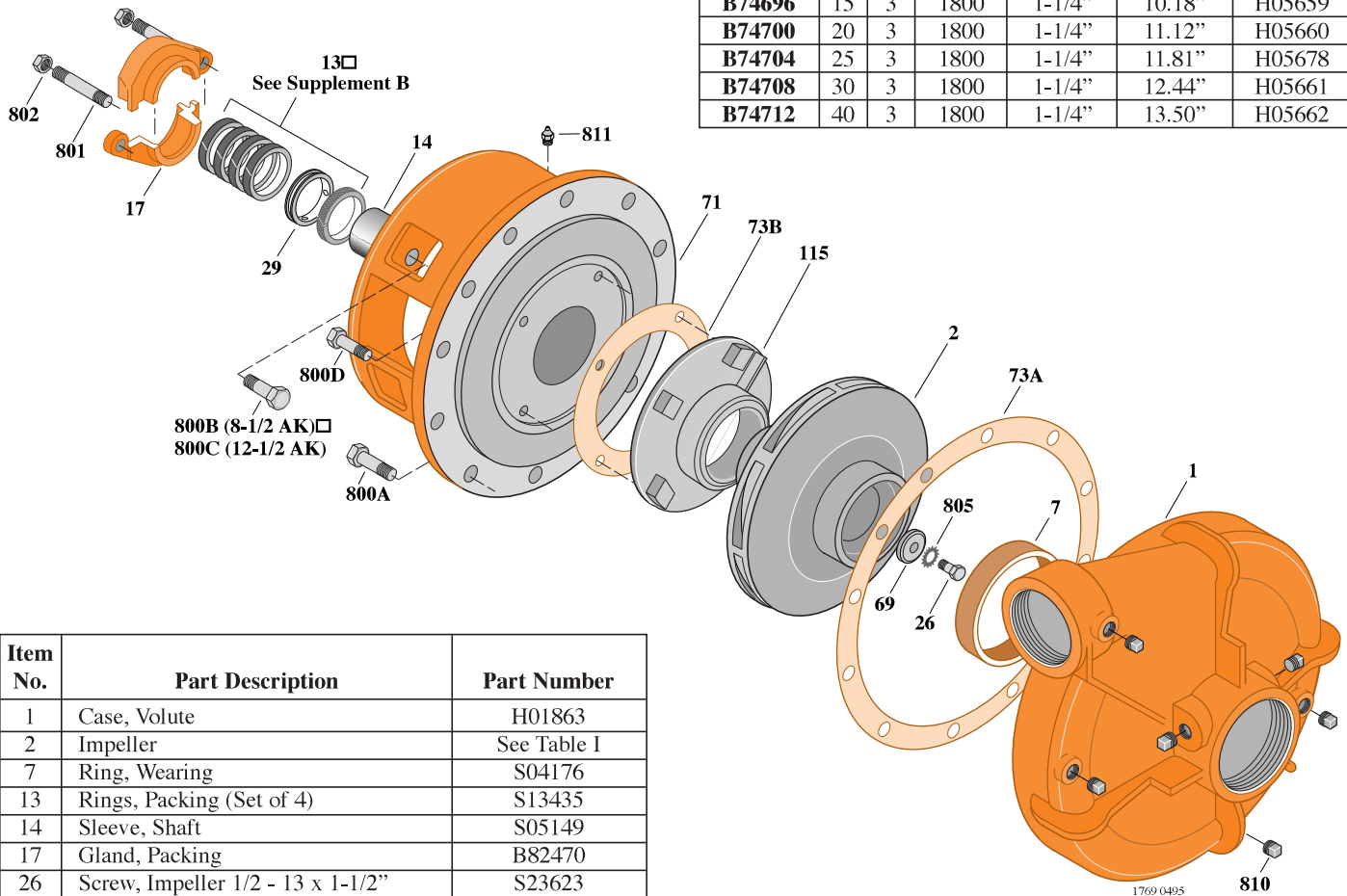

| Item No. | Part Description | Part Number |
|----------|---------------------------------------|--------------|
| 1 | Case, Volute | H01863 |
| 2 | Impeller | See Table I |
| 7 | Ring, Wearing | S04176 |
| 13 | Rings, Packing (Set of 4) | S13435 |
| 14 | Sleeve, Shaft | S05149 |
| 17 | Gland, Packing | B82470 |
| 26 | Screw, Impeller 1/2 - 13 x 1-1/2" | S23623 |
| 29 | Ring, Lantern | S19200 |
| 32 | Key, 1/4 x 2-1/4" (See Note) | S23677 |
| 69 | Washer, Impeller | S06319 |
| 71 | Bracket | See Table II |
| 73A | Gasket, Volute | S06271 |
| 73B | Gasket, Balance Ring | S09943 |
| 115 | Ring, Balance | M05115 |
| 800A | Capscrew, 5/8 - 11 x 1-1/2" (12 Req.) | S26999 |
| 800B | Capscrew, 1/2 - 13 x 1-1/2" (4 Req.) | S26916 |
| 800C | Capscrew, 5/8 - 11 x 1-1/2" (4 Req.) | S26999 |
| 800D | Capscrew, 3/8 - 16 x 1-1/2" (4 Req.) | S26830 |
| 801 | Stud, 3/8 - 16 x 2-1/2" (2 Req.) | S04438 |
| 802 | Nut, Hex 3/8 - 16 (2 Req.) | S23343 |
| 805 | Washer, Lock | S23038 |
| 810 | Plug, Pipe 1/2" NPT (6 Req.) | S23717 |
| 811 | Fitting, Grease | S23700 |

TABLE II

| HP | PH | Bracket No. | "AK" Fit | "U" Dim. | Motor Frame |
|----|----|-------------|----------|----------|-------------|
| 15 | 3 | H02384 | 8-1/2" | 1-1/4" | 254JP |
| 20 | 3 | H02384 | 8-1/2" | 1-1/4" | 256JP |
| 25 | 3 | H01601 | 12-1/2" | 1-1/4" | 284JP |
| 30 | 3 | H01601 | 12-1/2" | 1-1/4" | 286JP |
| 40 | 3 | H01601 | 12-1/2" | 1-1/4" | 324JP |

NOTE: For an explanation of the tabulated material found on this page and for impeller key location, refer to *Supplement A* located at the beginning of this section.

