



# TYPE "B" SINGLE STAGE CENTRIFUGAL PUMP Electric Motor Drive

Section	CC
Page	220.1
Date	January 1, 2004
Supersedes 6/1/95	

## CAST IRON IMPELLER

## B3EPM

### Threaded Case (NPT)

### Packing Construction

**TABLE I**

B/M No.	HP	PH	RPM	"U" Dim.	Imp. Dia.	Imp. No.
B53828	5	1	1800	1-1/4"	7.69"	M07697
B53830	5	3	1800	7/8"	7.69"	M07698

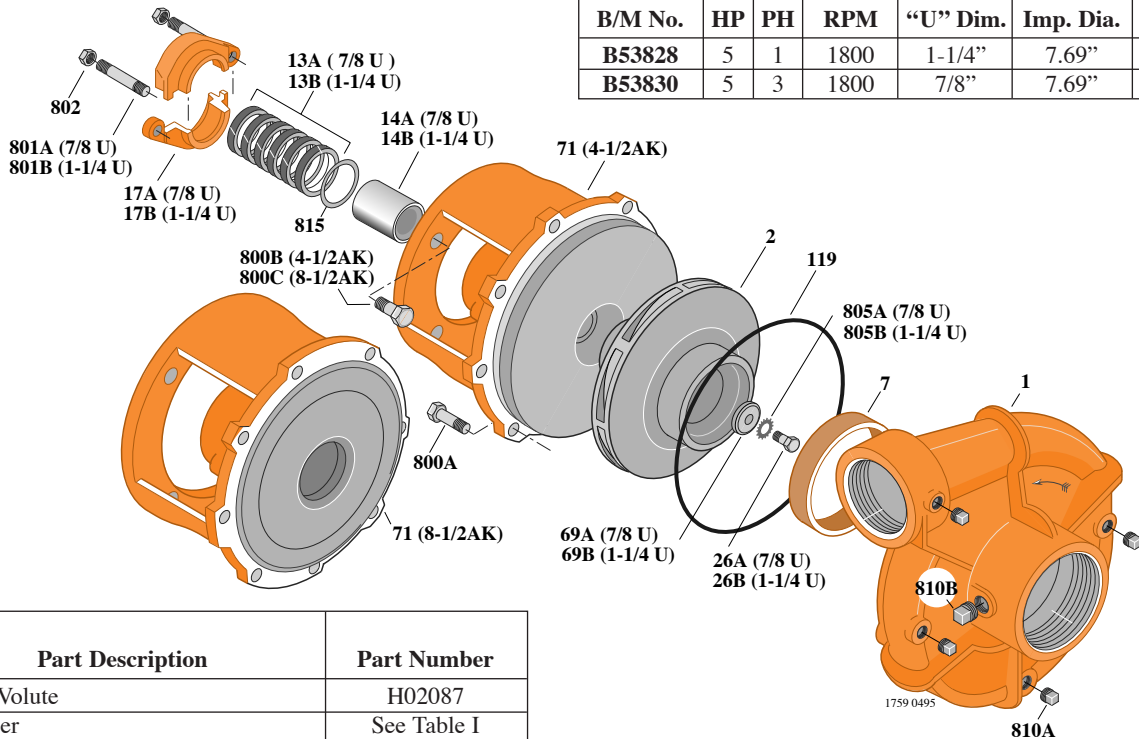

Item No.	Part Description	Part Number
1	Case, Volute	H02087
2	Impeller	See Table I
7	Ring, Wearing	S13045
13A	Rings, Packing (Set of 7)	S15094
13B	Rings, Packing (Set of 6)	S13470
14A	Sleeve, Shaft (2 Req.)	S00619
14B	Sleeve, Shaft	S05149
17A	Gland, Packing	B82469
17B	Gland, Packing	B82470
26A	Screw, Impeller 3/8 - 16 x 1-1/4"	S23568
26B	Screw, Impeller 1/2 - 13 x 1-3/4"	S23625
32A	Key, 3/16 x 1-1/4" (See Note)	S34383
32B	Key, 1/4 x 2-1/4" (See Note)	S23677
69A	Washer, Impeller	S06314
69B	Washer, Impeller	S06319
71	Bracket	See Table II
119	O-Ring	S13760
800A	Capscrew, 1/2 - 13 x 1-1/4" (8 Req.)	S26914
800B	Capscrew, 3/8 - 16 x 1" (4 Req.)	S26826
800C	Capscrew, 1/2 - 13 x 1-1/2" (4 Req.)	S26916
801A	Stud, 3/8 - 16 x 3" (2 Req.)	S04439
801B	Stud, 3/8 - 16 x 2-1/2" (2 Req.)	S04438
802	Nut, Hex 3/8 - 16 (2 Req.)	S23343
805A	Washer, Lock	S23026
805B	Washer, Lock	S23038
810A	Plug, Pipe 1/4 NPT (4 Req.)	S23715
810B	Plug, Pipe 1/2 NPT	S23717
815	Ring, Retainer	S08778

**TABLE II**

HP	PH	Bracket No.	"AK" Fit	"U" Dim.	Motor Frame
5	1	L03637	8-1/2"	1-1/4"	213JP
5	3	L05114	4-1/2"	7/8"	184JP

**NOTE:** For an explanation of the tabulated material found on this page and for impeller key location, refer to *Supplement A* located at the beginning of this section.



# TYPE "B" SINGLE STAGE CENTRIFUGAL PUMP Electric Motor Drive

Section	CC
Page	220.2
Date	January 1, 2004
Supersedes 6/1/95	

## CAST IRON IMPELLER

## B3EPM

### Threaded Case (NPT)

### Packing Construction

TABLE I

B/M No.	HP	PH	RPM	"U" Dim.	Imp. Dia.	Imp. No.
B53829	7.5	1	1800	1-1/4"	8.69"	M07699
B53831	7.5	3	1800	1-1/4"	8.69"	M07699
B55580	10	1	1800	1-1/4"	9.38"	M07700
B53832	10	3	1800	1-1/4"	9.38"	M07700
B51716	15	3	1800	1-1/4"	10.44"	M04820

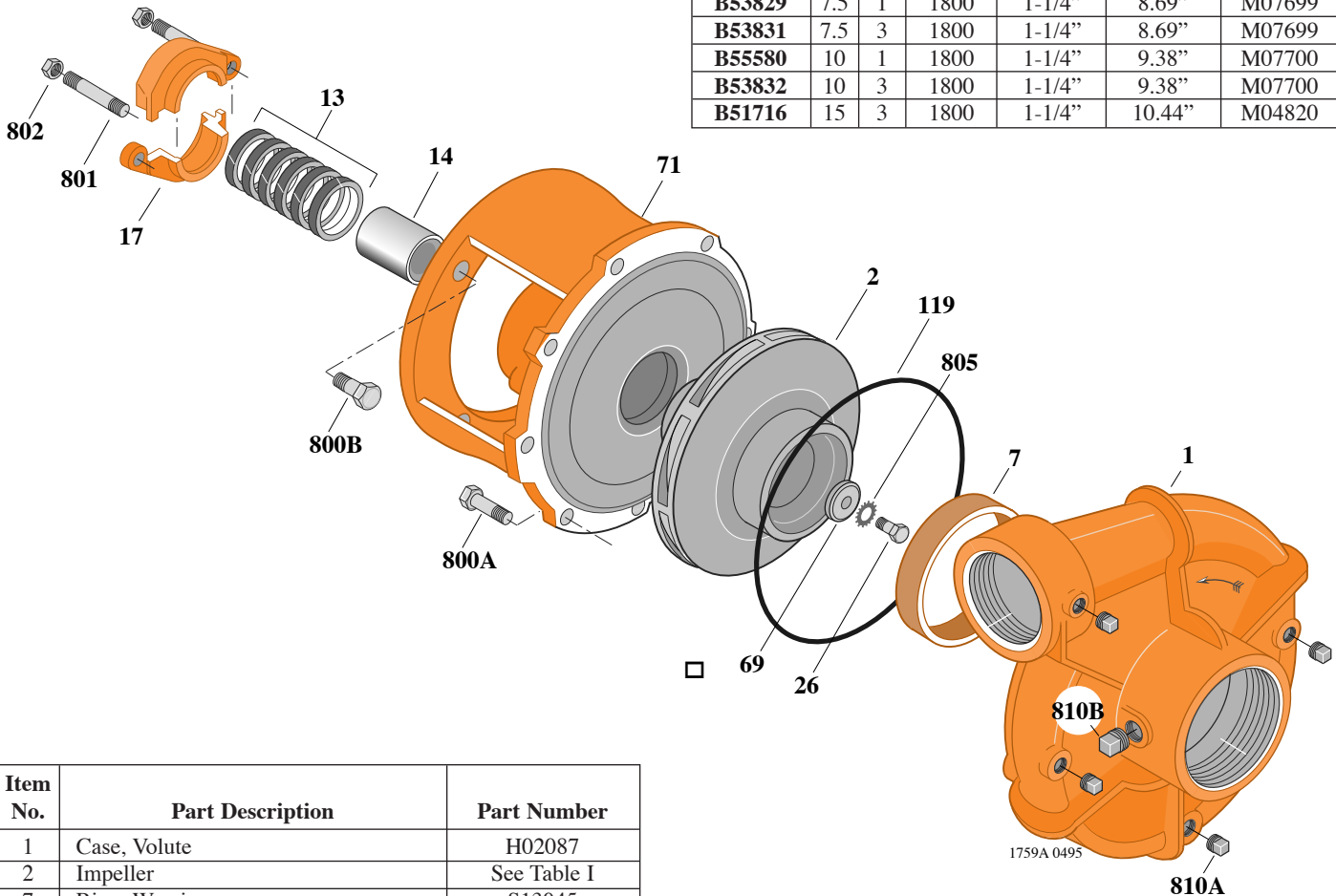

Item No.	Part Description	Part Number
1	Case, Volute	H02087
2	Impeller	See Table I
7	Ring, Wearing	S13045
13	Rings, Packing (Set of 6)	S13470
14	Sleeve, Shaft	S05149
17	Gland, Packing	B82470
26	Screw, Impeller 1/2 - 13 x 1-3/4"	S23625
32	Key, 1/4 x 2-1/4" (See Note)	S23677
69	Washer, Impeller	S06319
71	Bracket	See Table II
119	O-Ring	S13760
800A	Capscrew, 1/2 - 13 x 1-1/4" (8 Req.)	S26914
800B	Capscrew, 1/2 - 13 x 1-1/2" (4 Req.)	S26916
801	Stud, 3/8 - 16 x 2-1/2" (2 Req.)	S04438
802	Nut, Hex 3/8 - 16 (2 Req.)	S23343
805	Washer, Lock	S23038
810A	Plug, Pipe 1/4 NPT (4 Req.)	S23715
810B	Plug, Pipe 1/2 NPT	S23717

TABLE II

HP	PH	Bracket No.	"AK" Fit	"U" Dim.	Motor Frame
7.5	1	L03637	8-1/2"	1-1/4"	215JP
7.5	3	L03637	8-1/2"	1-1/4"	213JP
10	1	L03637	8-1/2"	1-1/4"	215JP
10	3	L03637	8-1/2"	1-1/4"	215JP
15	3	L03637	8-1/2"	1-1/4"	254JP

**NOTE:** For an explanation of the tabulated material found on this page and for impeller key location, refer to *Supplement A* located at the beginning of this section.



# TYPE "B" SINGLE STAGE CENTRIFUGAL PUMP Electric Motor Drive

Section	CC
Page	220.3
Date	May 15, 2009
Supersedes 1/1/04	

**CAST IRON IMPELLER**

**B3EPMS**

**Threaded Case (NPT)**

**Mechanical Shaft Seal Construction**

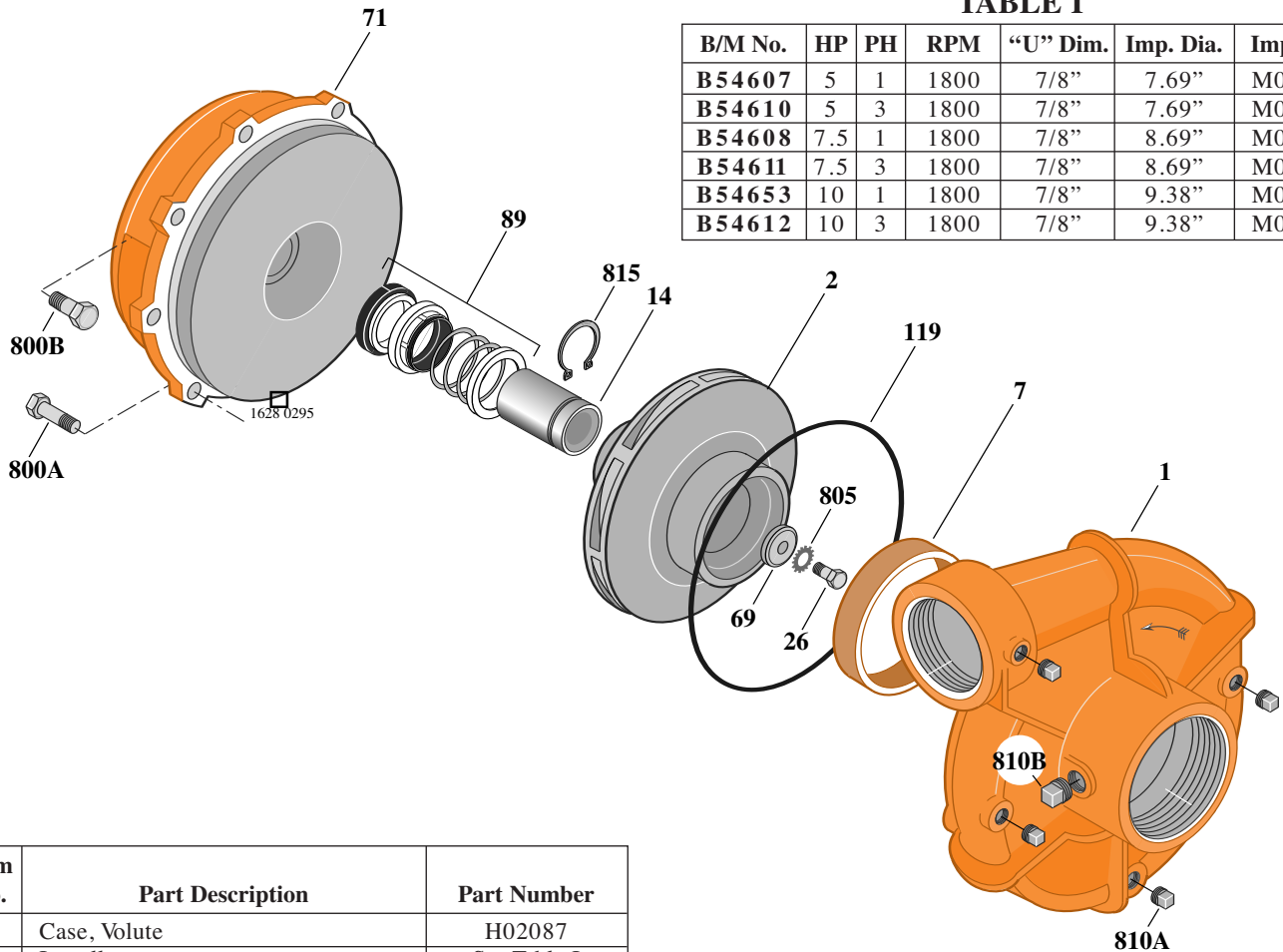

**TABLE I**

B/M No.	HP	PH	RPM	"U" Dim.	Imp. Dia.	Imp. No.
<b>B54607</b>	5	1	1800	7/8"	7.69"	M07698
<b>B54610</b>	5	3	1800	7/8"	7.69"	M07698
<b>B54608</b>	7.5	1	1800	7/8"	8.69"	M07752
<b>B54611</b>	7.5	3	1800	7/8"	8.69"	M07752
<b>B54653</b>	10	1	1800	7/8"	9.38"	M04817
<b>B54612</b>	10	3	1800	7/8"	9.38"	M04817

Item No.	Part Description	Part Number
1	Case, Volute	H02087
2	Impeller	See Table I
7	Ring, Wearing	S13045
14	Sleeve, Shaft (See Note 2)	S19310L
26	Screw, Impeller 3/8 - 16 x 1-1/4"	S23568
32	Key, 3/16 x 1-1/4" (See Note 1)	S34383
69	Washer, Impeller	S06314
71	Bracket	See Table II
89	Seal, Mechanical Shaft	S32014
119	O-Ring	S13760
800A	Capscrew, 1/2 - 13 x 1-1/4" (8 Req.)	S26914
800B	Capscrew, 1/2 - 13 x 1" (For 8-1/2 AK)	S26912
800B	Capscrew, 3/8 - 16 x 1" (For 4-1/2 AK)	S26826
805	Washer, Lock	S23036
810A	Plug, Pipe 1/4 NPT (4 Req.)	S23715
810B	Plug, Pipe 1/2 NPT	S23717
815	Ring, Retaining	S11207

**TABLE II**

HP	PH	Bracket No.	"AK" Fit	"U" Dim.	Motor Frame
5	1	L05334	8-1/2"	7/8"	213JM
5	3	L05335	4-1/2"	7/8"	184JM
7.5	1	L05334	8-1/2"	7/8"	215JM
7.5	3	L05334	8-1/2"	7/8"	213JM
10	1	L05334	8-1/2"	7/8"	215JM
10	3	L05334	8-1/2"	7/8"	215JM

**NOTE 1:** For an explanation of the tabulated material found on this page and for impeller key location, refer to *Supplement A* located at the beginning of this section.

**NOTE 2:** Sleeve replacement kit available. Berkeley part number B85681 includes the shaft sleeve, adhesive compound and instruction sheet.



# TYPE "B" SINGLE STAGE CENTRIFUGAL PUMP Electric Motor Drive

Section	CC
Page	220.4
Date	January 1, 2004
Supersedes 6/1/95	

## CAST IRON IMPELLER

## B3EPMS

### Threaded Case (NPT)

### Mechanical Shaft Seal Construction

**TABLE I**

B/M No.	HP	PH	RPM	"U" Dim.	Imp. Dia.	Imp. No.
<b>B54125</b>	15	3	1800	1-1/4"	10.44	M04820

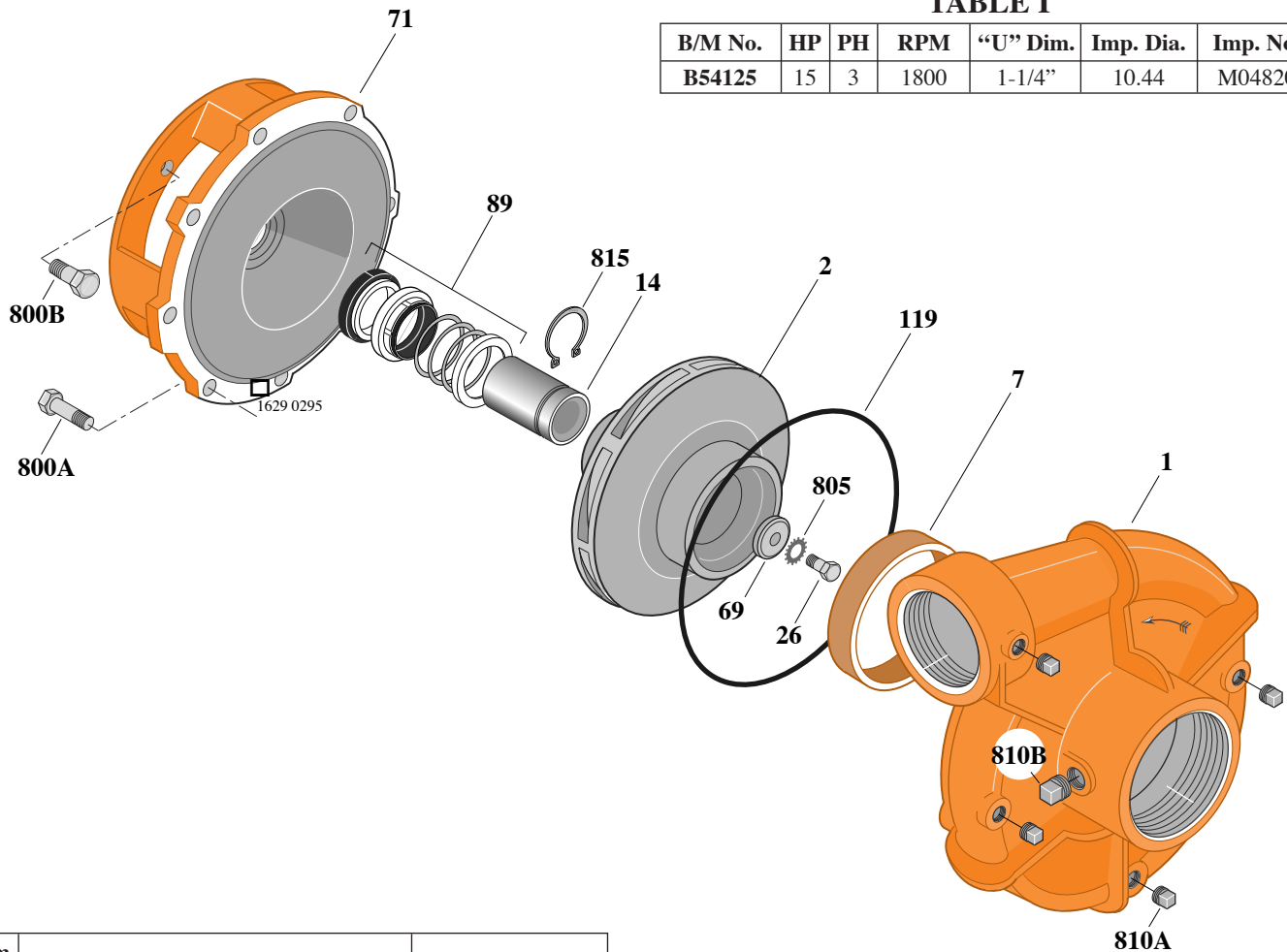

Item No.	Part Description	Part Number
1	Case, Volute	H02087
2	Impeller	See Table I
7	Ring, Wearing	S13045
14	Sleeve, Shaft	S18869
26	Screw, Impeller 1/2 - 13 x 1-3/4"	S23625
32	Key, 1/4 x 2-1/4" (See Note)	S23677
69	Washer, Impeller	S06319
71	Bracket	See Table II
89	Seal, Mechanical Shaft	S32015
119	O-Ring	S13760
800A	Capscrew, 1/2 - 13 x 1-1/4" (8 Req.)	S26914
800B	Capscrew, 1/2 - 13 x 1" (4 Req.)	S26912
805	Washer, Lock	S23038
810A	Plug, Pipe 1/4 NPT (4 Req.)	S23715
810B	Plug, Pipe 1/2 NPT	S23717
815	Ring, Retaining	S16767

**TABLE II**

HP	PH	Bracket No.	"AK" Fit	"U" Dim.	Motor Frame
15	3	L04616	8-1/2"	1-1/4"	254JM

**NOTE:** For an explanation of the tabulated material found on this page and for impeller key location, refer to *Supplement A* located at the beginning of this section.