



TYPE "B" SINGLE STAGE CENTRIFUGAL PUMP Electric Motor Drive

Section	CC
Page	210.1
Date	January 1, 2004
Supersedes 6/1/95	

CAST IRON IMPELLER

B3EPBL

Threaded Case (NPT)

Packing Construction

TABLE I

B/M No.	HP	PH	RPM	"U" Dim.	Imp. Dia.	Imp. No.
B58054	40	3	3600	1-1/4"	7.81"	M07701
B58055	50	3	3600	1-1/4"	8.56"	M07702
B58056	60	3	3600	1-1/4"	9.25"	M07703

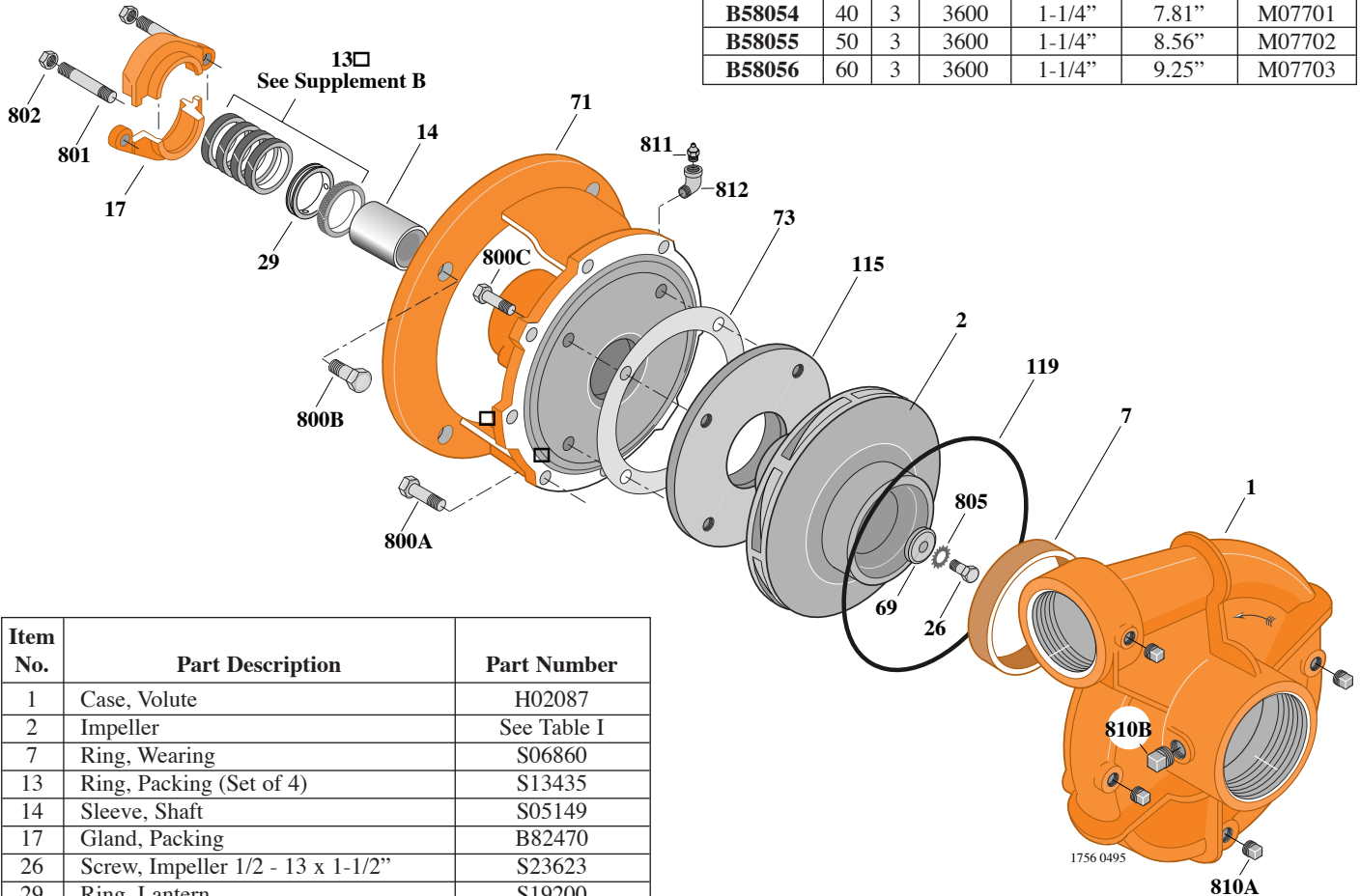

Item No.	Part Description	Part Number
1	Case, Volute	H02087
2	Impeller	See Table I
7	Ring, Wearing	S06860
13	Ring, Packing (Set of 4)	S13435
14	Sleeve, Shaft	S05149
17	Gland, Packing	B82470
26	Screw, Impeller 1/2 - 13 x 1-1/2"	S23623
29	Ring, Lantern	S19200
32	Key, 1/4 x 2-1/4" (See Note)	S23677
69	Washer, Impeller	S18117
71	Bracket	See Table II
73	Gasket, Balance Ring	S09943
115	Ring, Balance	L03648
119	O-Ring	S13760
800A	Capscrew, 1/2 - 13 x 1-1/4" (8 Req.)	S26914
800B	Capscrew, 5/8 - 11 x 1-1/2" (4 Req.)	S26999
800C	Capscrew, 3/8 - 16 x 1" (4 Req.)	S26826
801	Stud, 3/8 - 16 x 2-1/2" (2 Req.)	S04438
802	Nut, Hex 3/8 - 16 (2 Req.)	S23343
805	Washer, Lock	S23038
810A	Plug, Pipe 1/4 NPT (4 Req.)	S23715
810B	Plug, Pipe 1/2 NPT	S23717
811	Fitting, Grease	S23700
812	Elbow, Street	S25421

TABLE II

HP	PH	Bracket No.	"AK" Fit	"U" Dim.	Motor Frame
40	3	L03497	12-1/2"	1-1/4"	286JP
50	3	L03497	12-1/2"	1-1/4"	324JP
60	3	L03497	12-1/2"	1-1/4"	326JP

NOTE: For an explanation of the tabulated material found on this page and for impeller key location, refer to *Supplement A* located at the beginning of this section.



TYPE "B" SINGLE STAGE CENTRIFUGAL PUMP Electric Motor Drive

Section	CC
Page	210.2
Date	January 1, 2004
Supersedes 6/1/95	

CAST IRON IMPELLER

B3EPBL

Threaded Case (NPT)

Packing Construction

TABLE I

B/M No.	HP	PH	RPM	"U" Dim.	Imp. Dia.	Imp. No.
B58057	75	3	3600	1-5/8"	10.12"	L06116

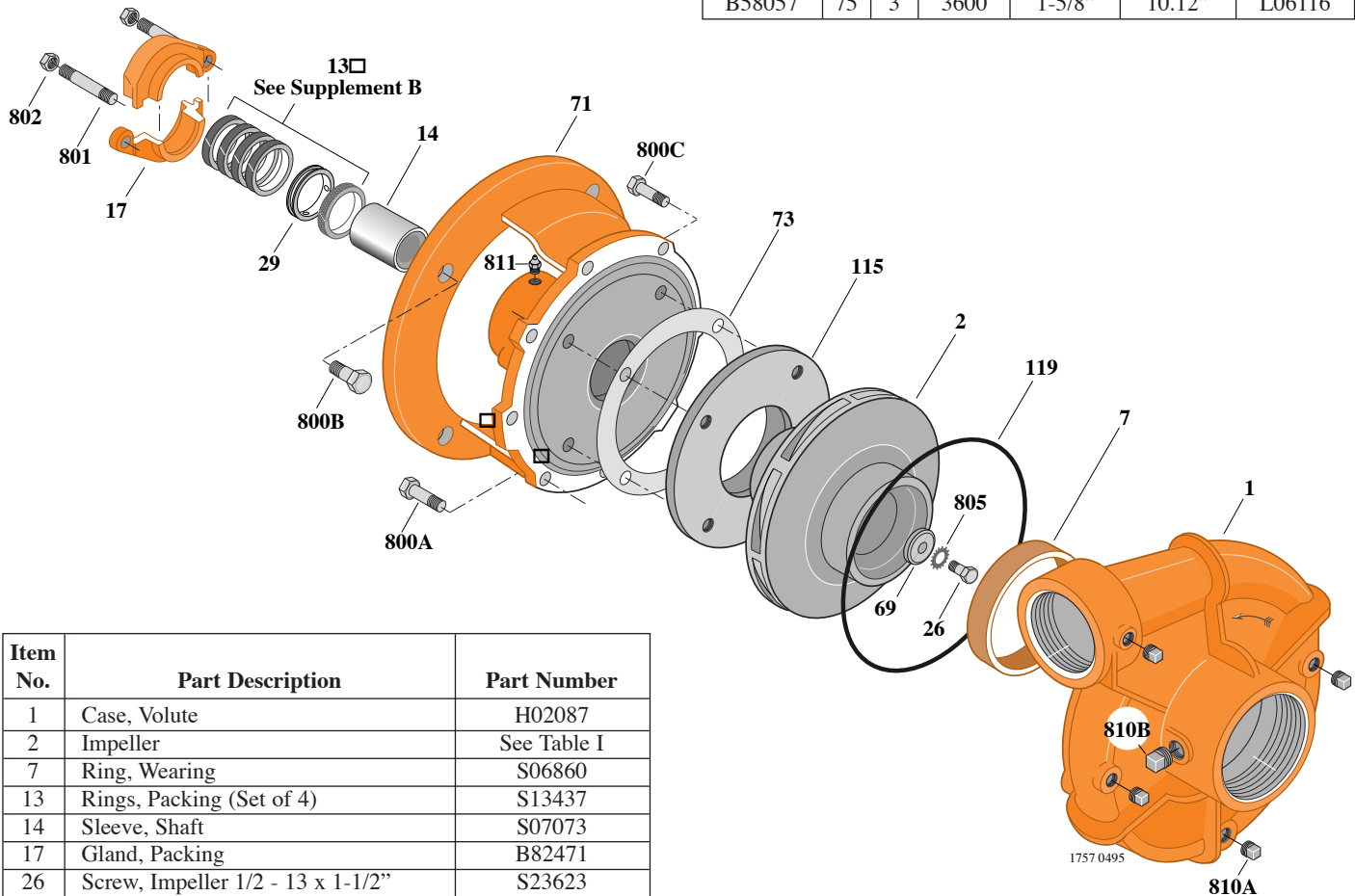

Item No.	Part Description	Part Number
1	Case, Volute	H02087
2	Impeller	See Table I
7	Ring, Wearing	S06860
13	Rings, Packing (Set of 4)	S13437
14	Sleeve, Shaft	S07073
17	Gland, Packing	B82471
26	Screw, Impeller 1/2 - 13 x 1-1/2"	S23623
29	Ring, Lantern	S19198
32	Key, 3/8 x 2-1/4" (See Note)	S23940
69	Washer, Impeller	S18801
71	Bracket	See Table II
73	Gasket, Balance Ring	S09943
115	Ring, Balance	L03697
119	O-Ring	S13760
800A	Capscrew, 1/2 - 13 x 1-1/4" (8 Req.)	S26914
800B	Capscrew, 5/8 - 11 x 1-1/2" (4 Req.)	S26999
800C	Capscrew, 3/8 - 16 1" (4 Req.)	S26826
801	Stud, 3/8 - 16 x 2-1/2" (2 Req.)	S04438
802	Nut, Hex 3/8 - 16 (2 Req.)	S23343
805	Washer, Lock	S23038
810A	Plug, Pipe 1/4 NPT (4 Req.)	S23715
810B	Plug, Pipe 1/2 NPT	S23717
811	Fitting, Grease	S23700

TABLE II

HP	PH	Bracket No.	"AK" Fit	"U" Dim.	Motor Frame
75	3	L05610	12-1/2"	1-5/8"	364JP

NOTE: For an explanation of the tabulated material found on this page and for impeller key location, refer to *Supplement A* located at the beginning of this section.



TYPE "B" SINGLE STAGE CENTRIFUGAL PUMP Electric Motor Drive

Section	CC
Page	210.3
Date	January 1, 2004
Supersedes 6/1/95	

CAST IRON IMPELLER

B3EPBLS

Threaded Case (NPT)

Mechanical Shaft Seal Construction

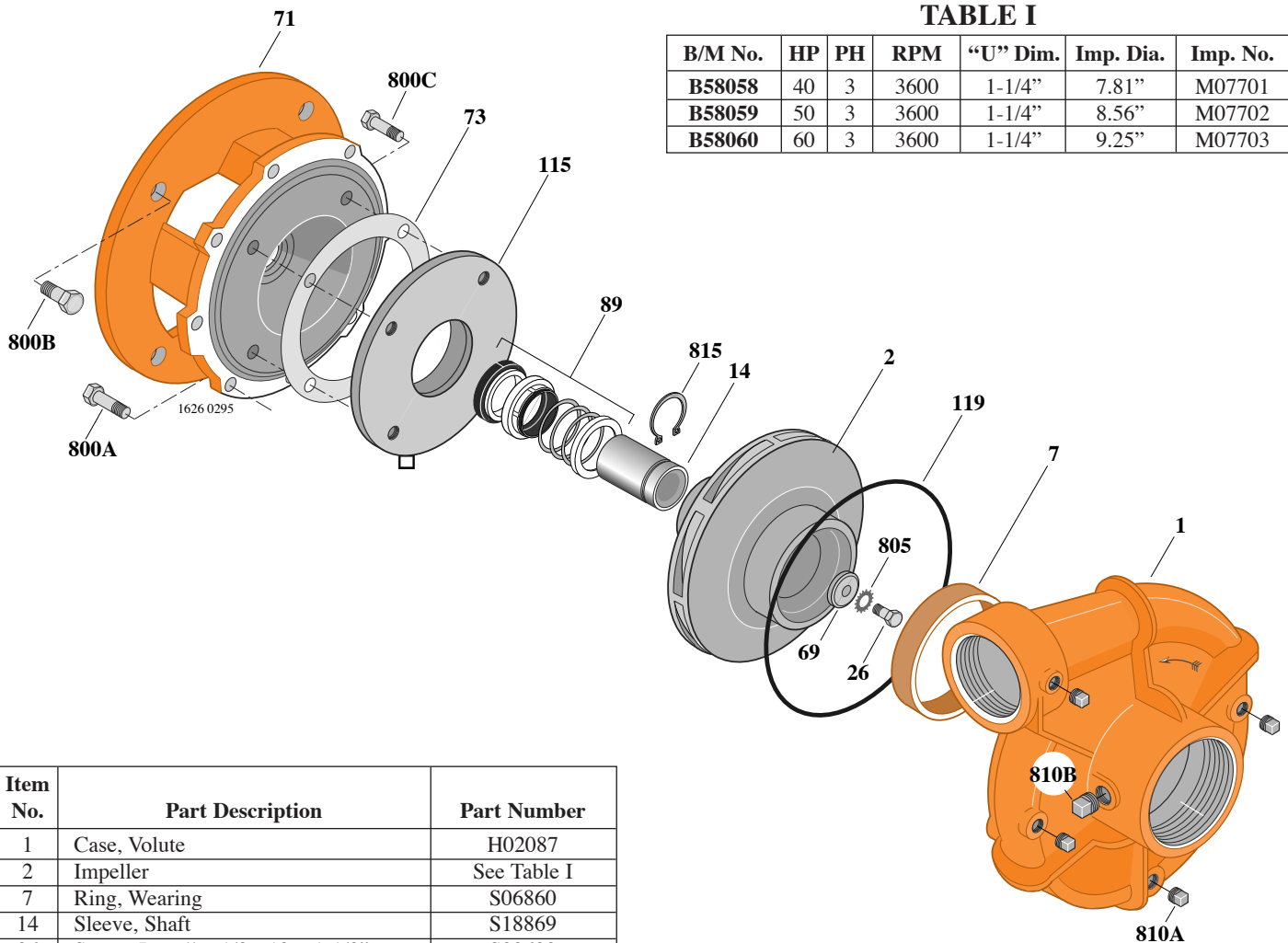

TABLE I

B/M No.	HP	PH	RPM	"U" Dim.	Imp. Dia.	Imp. No.
B58058	40	3	3600	1-1/4"	7.81"	M07701
B58059	50	3	3600	1-1/4"	8.56"	M07702
B58060	60	3	3600	1-1/4"	9.25"	M07703

Item No.	Part Description	Part Number
1	Case, Volute	H02087
2	Impeller	See Table I
7	Ring, Wearing	S06860
14	Sleeve, Shaft	S18869
26	Screw, Impeller 1/2 - 13 x 1-1/2"	S23623
32	Key, 1/4 x 2-1/4" (See Note)	S23677
69	Washer, Impeller	S18117
71	Bracket	See Table II
73	Gasket, Balance Ring	S09943
89	Seal, Mechanical Shaft	S32015
105	Washer, Lock	S23038
115	Ring, Balance	L05262
119	O-Ring	S13760
800A	Capscrew, 1/2 - 13 x 1-1/4" (8 Req.)	S26914
800B	Capscrew, 5/8 - 11 x 1-1/2" (4 Req.)	S26999
800C	Capscrew, 3/8 - 16 x 3/4" (4 Req.)	S26824
805	Washer, Lock	S23038
810A	Plug, Pipe 1/4 NPT (4 Req.)	S23715
810B	Plug, Pipe 1/2 NPT	S23717
815	Ring, Retaining	S16767

TABLE II

HP	PH	Bracket No.	"AK" Fit	"U" Dim.	Motor Frame
40	3	L04628	12-1/2"	1-1/4"	286JM
50	3	L04628	12-1/2"	1-1/4"	324JM
60	3	L04628	12-1/2"	1-1/4"	326JM

NOTE: For an explanation of the tabulated material found on this page and for impeller key location, refer to *Supplement A* located at the beginning of this section.



TYPE "B" SINGLE STAGE CENTRIFUGAL PUMP Electric Motor Drive

Section	CC
Page	210.4
Date	January 1, 2004
Supersedes 6/1/95	

CAST IRON IMPELLER

B3EPBLS

Threaded Case (NPT)

Mechanical Shaft Seal Construction

TABLE I

B/M No.	HP	PH	RPM	"U" Dim.	Imp. Dia.	Imp. No.
B60609	75	3	3600	1-5/8"	10.12"	L06116

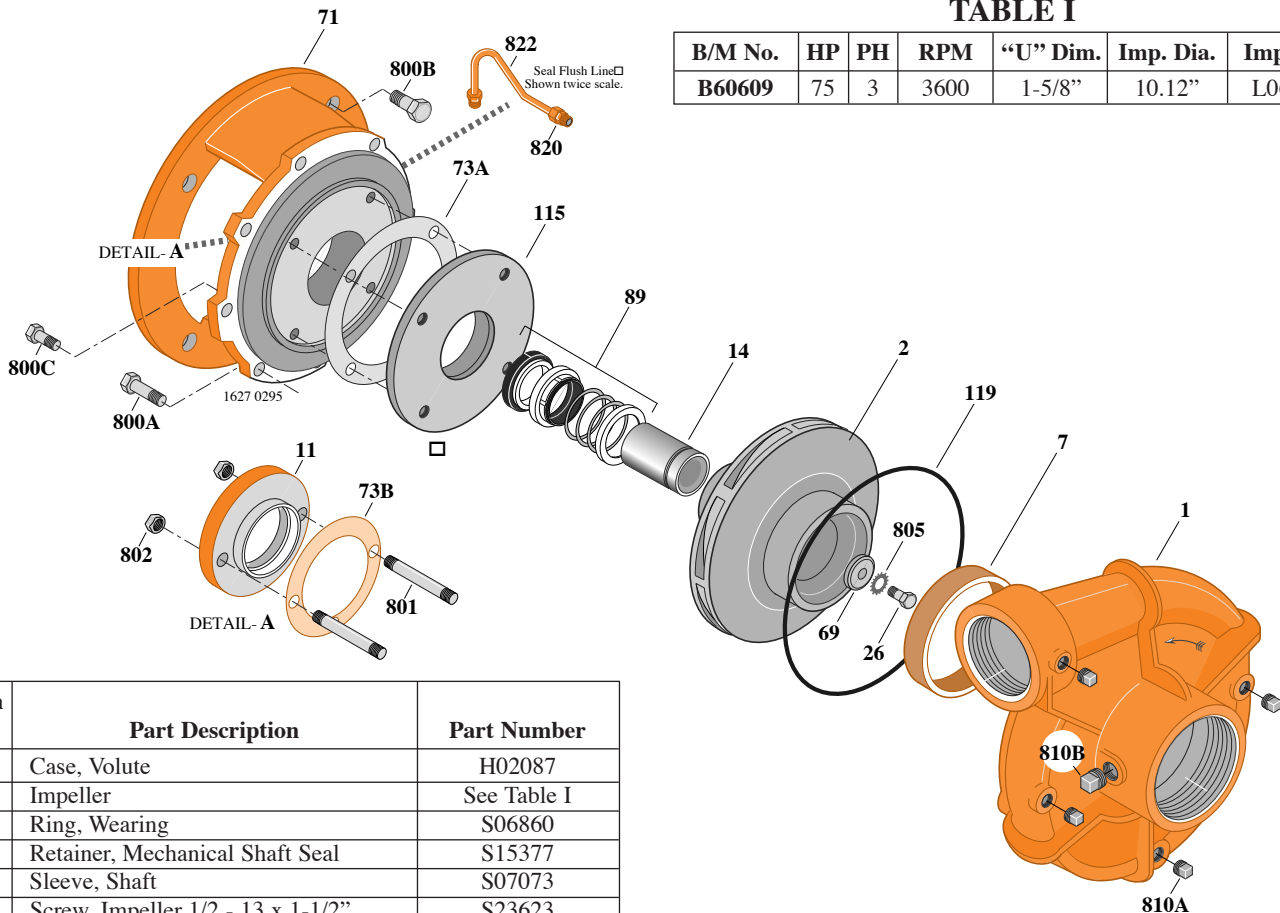

Item No.	Part Description	Part Number
1	Case, Volute	H02087
2	Impeller	See Table I
7	Ring, Wearing	S06860
11	Retainer, Mechanical Shaft Seal	S15377
14	Sleeve, Shaft	S07073
26	Screw, Impeller 1/2 - 13 x 1-1/2"	S23623
32	Key, 3/8 x 2-1/4" (See Note)	S23940
69	Washer, Impeller	S18801
71	Bracket	See Table II
73A	Gasket, Balance Ring	S09943
73B	Gasket, Seal Retainer	S15078
89	Seal, Mechanical Shaft	S32016
115	Ring, Balance	L03697
119	O-Ring	S13760
800A	Capscrew, 1/2 - 13 x 1-1/4" (8 Req.)	S26914
800B	Capscrew, 5/8 - 11 x 1-3/4" (4 Req.)	S27001
800C	Capscrew, 3/8 - 16 x 1" (4 Req.)	S26826
801	Stud, 3/8 - 16 x 2-1/2" (2 Req.)	S04438
802	Nut, 3/8 - 16 (2 Req.)	S23343
805	Washer, Lock	S23038
810A	Plug, Pipe 1/4 NPT (4 Req.)	S23715
810B	Plug, Pipe 1/2 NPT	S23717
820	Connector, Comp. Fitting (2 Req.)	S24013
822	Tubing, Copper	S20677
•	Plug, Pipe 1/8 NPT (At Seal Bore)	S23714

TABLE II

HP	PH	Bracket No.	"AK" Fit	"U" Dim.	Motor Frame
75	3	L06315	12-1/2"	1-5/8"	364JP

NOTE: For an explanation of the tabulated material found on this page and for impeller key location, refer to *Supplement A* located at the beginning of this section.



TYPE "B" SINGLE STAGE CENTRIFUGAL PUMP Electric Motor Drive

Section	CC
Page	210.5
Date	January 1, 2004
Supersedes/New	

BRONZE IMPELLER

B3EPBLS

Threaded Case (NPT)

Mechanical Shaft Seal Construction

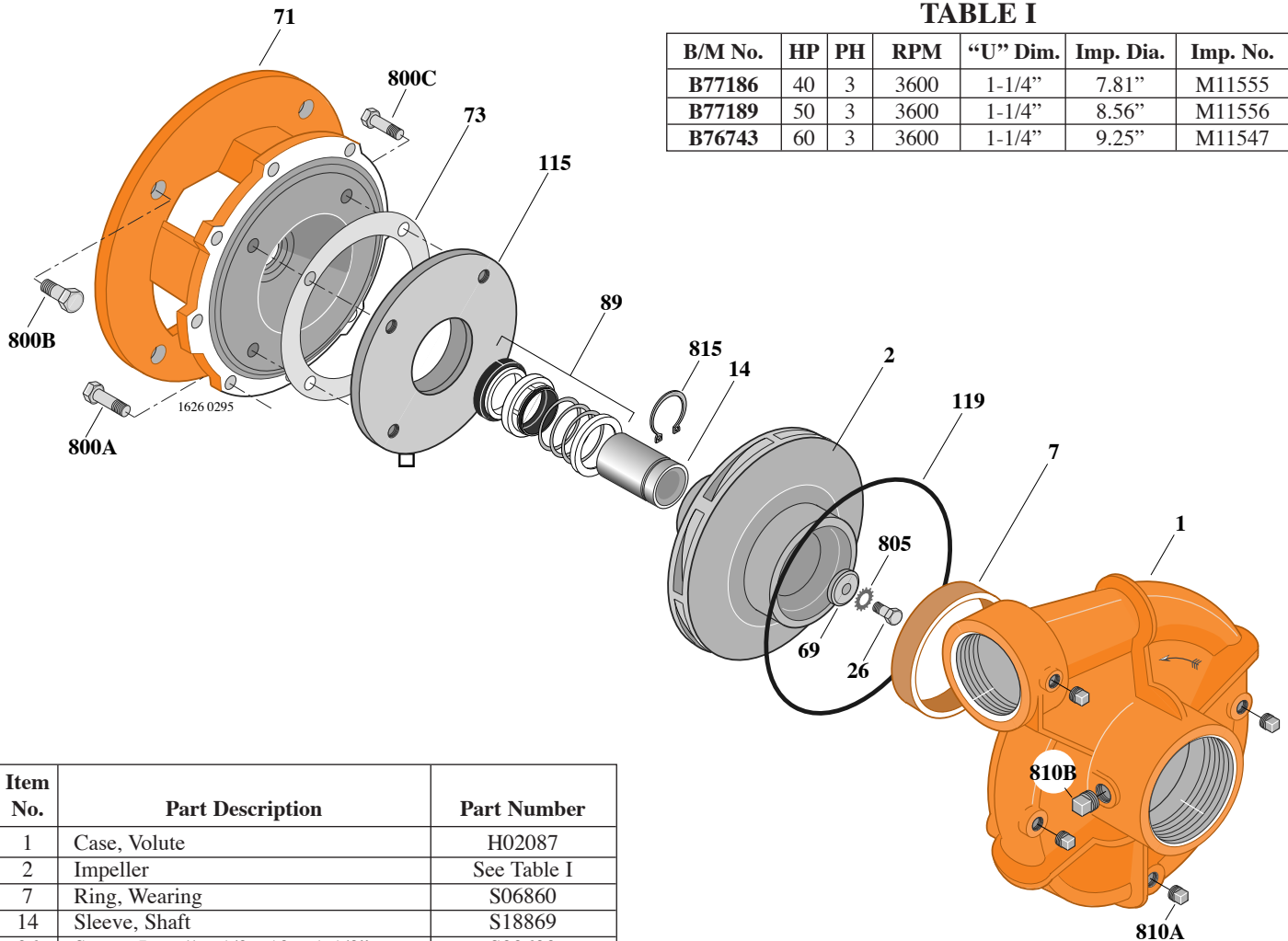

TABLE I

B/M No.	HP	PH	RPM	"U" Dim.	Imp. Dia.	Imp. No.
B77186	40	3	3600	1-1/4"	7.81"	M11555
B77189	50	3	3600	1-1/4"	8.56"	M11556
B76743	60	3	3600	1-1/4"	9.25"	M11547

Item No.	Part Description	Part Number
1	Case, Volute	H02087
2	Impeller	See Table I
7	Ring, Wearing	S06860
14	Sleeve, Shaft	S18869
26	Screw, Impeller 1/2 - 13 x 1-1/2"	S23623
32	Key, 1/4 x 2-1/4" (See Note)	S23677
69	Washer, Impeller	S18117
71	Bracket	See Table II
73	Gasket, Balance Ring	S09943
89	Seal, Mechanical Shaft	S32015
105	Washer, Lock	S23038
115	Ring, Balance	L05262
119	O-Ring	S13760
800A	Capscrew, 1/2 - 13 x 1-1/4" (8 Req.)	S26914
800B	Capscrew, 5/8 - 11 x 1-1/2" (4 Req.)	S26999
800C	Capscrew, 3/8 - 16 x 3/4" (4 Req.)	S26824
805	Washer, Lock	S23038
810A	Plug, Pipe 1/4 NPT (4 Req.)	S23715
810B	Plug, Pipe 1/2 NPT	S23717
815	Ring, Retaining	S16767

TABLE II

HP	PH	Bracket No.	"AK" Fit	"U" Dim.	Motor Frame
40	3	L04628	12-1/2"	1-1/4"	286JM
50	3	L04628	12-1/2"	1-1/4"	324JM
60	3	L04628	12-1/2"	1-1/4"	326JM

NOTE: For an explanation of the tabulated material found on this page and for impeller key location, refer to *Supplement A* located at the beginning of this section.



TYPE "B" SINGLE STAGE CENTRIFUGAL PUMP Electric Motor Drive

Section	CC
Page	210.6
Date	January 1, 2004
Supersedes/New	

BRONZE IMPELLER

B3EPBLS

Threaded Case (NPT)

Mechanical Shaft Seal Construction

TABLE I

B/M No.	HP	PH	RPM	"U" Dim.	Imp. Dia.	Imp. No.
B77192	75	3	3600	1-5/8"	10.12"	M11554

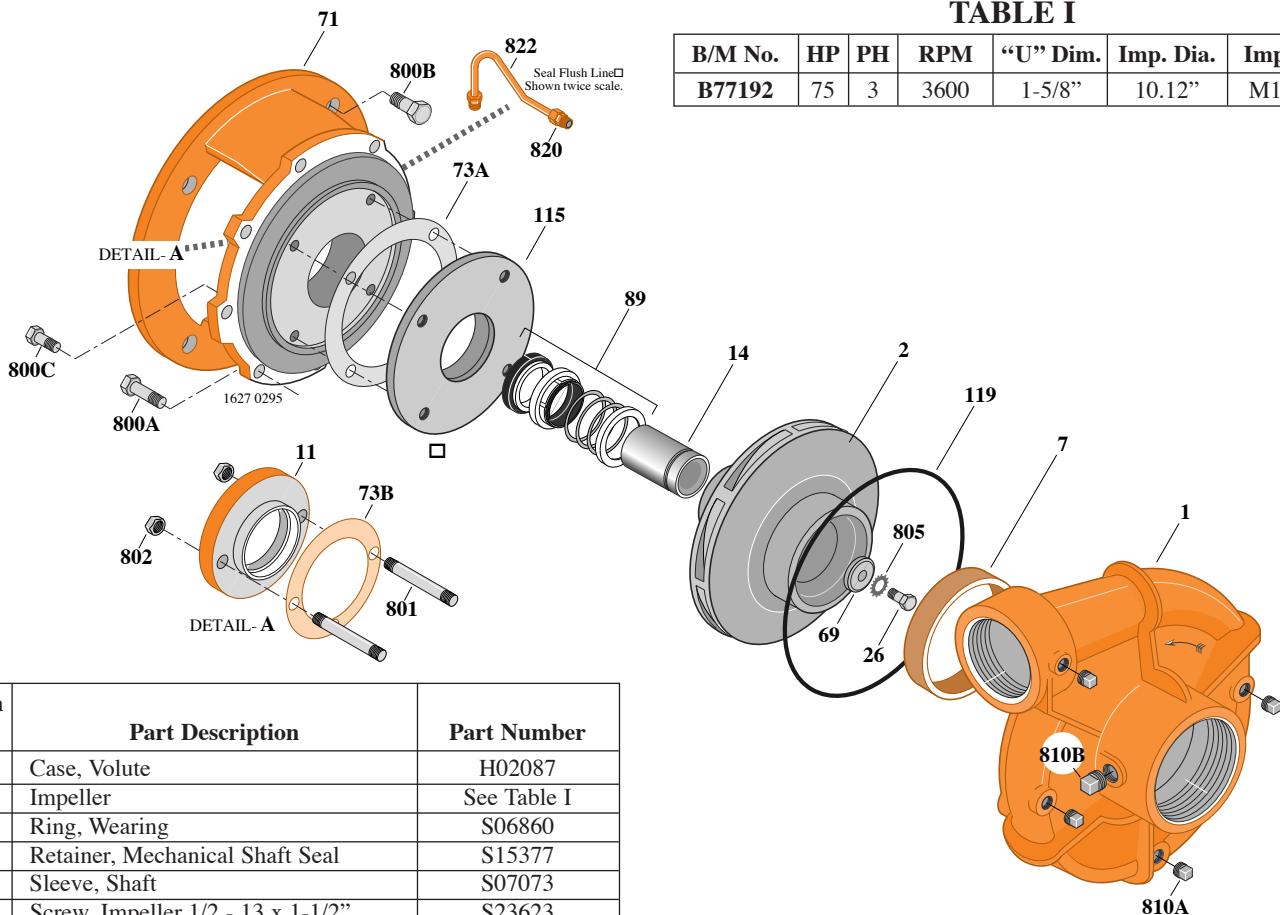

Item No.	Part Description	Part Number
1	Case, Volute	H02087
2	Impeller	See Table I
7	Ring, Wearing	S06860
11	Retainer, Mechanical Shaft Seal	S15377
14	Sleeve, Shaft	S07073
26	Screw, Impeller 1/2 - 13 x 1-1/2"	S23623
32	Key, 3/8 x 2-1/4" (See Note)	S23940
69	Washer, Impeller	S18801
71	Bracket	See Table II
73A	Gasket, Balance Ring	S09943
73B	Gasket, Seal Retainer	S15078
89	Seal, Mechanical Shaft	S32016
115	Ring, Balance	L03697
119	O-Ring	S13760
800A	Capscrew, 1/2 - 13 x 1-1/4" (8 Req.)	S26914
800B	Capscrew, 5/8 - 11 x 1-3/4" (4 Req.)	S27001
800C	Capscrew, 3/8 - 16 x 1" (4 Req.)	S26826
801	Stud, 3/8 - 16 x 2-1/2" (2 Req.)	S04438
802	Nut, 3/8 - 16 (2 Req.)	S23343
805	Washer, Lock	S23038
810A	Plug, Pipe 1/4 NPT (4 Req.)	S23715
810B	Plug, Pipe 1/2 NPT	S23717
820	Connector, Comp. Fitting (2 Req.)	S24013
822	Tubing, Copper	S20677
•	Plug, Pipe 1/8 NPT (At Seal Bore)	S23714

TABLE II

HP	PH	Bracket No.	"AK" Fit	"U" Dim.	Motor Frame
75	3	L06315	12-1/2"	1-5/8"	364JP

NOTE: For an explanation of the tabulated material found on this page and for impeller key location, refer to *Supplement A* located at the beginning of this section.



TYPE "B" SINGLE STAGE CENTRIFUGAL PUMP Electric Motor Drive

Section	CC
Page	210.7
Date	January 1, 2004
Supersedes/New	

BRONZE IMPELLER

B3EPBLS

Flanged Case

Mechanical Shaft Seal Construction

TABLE I

B/M No.	HP	PH	RPM	"U" Dim.	Imp. Dia.	Imp. No.
B76763	40	3	3600	1-1/4"	7.81"	M11555
B76764	50	3	3600	1-1/4"	8.56"	M11556
B76765	60	3	3600	1-1/4"	9.25"	M11547

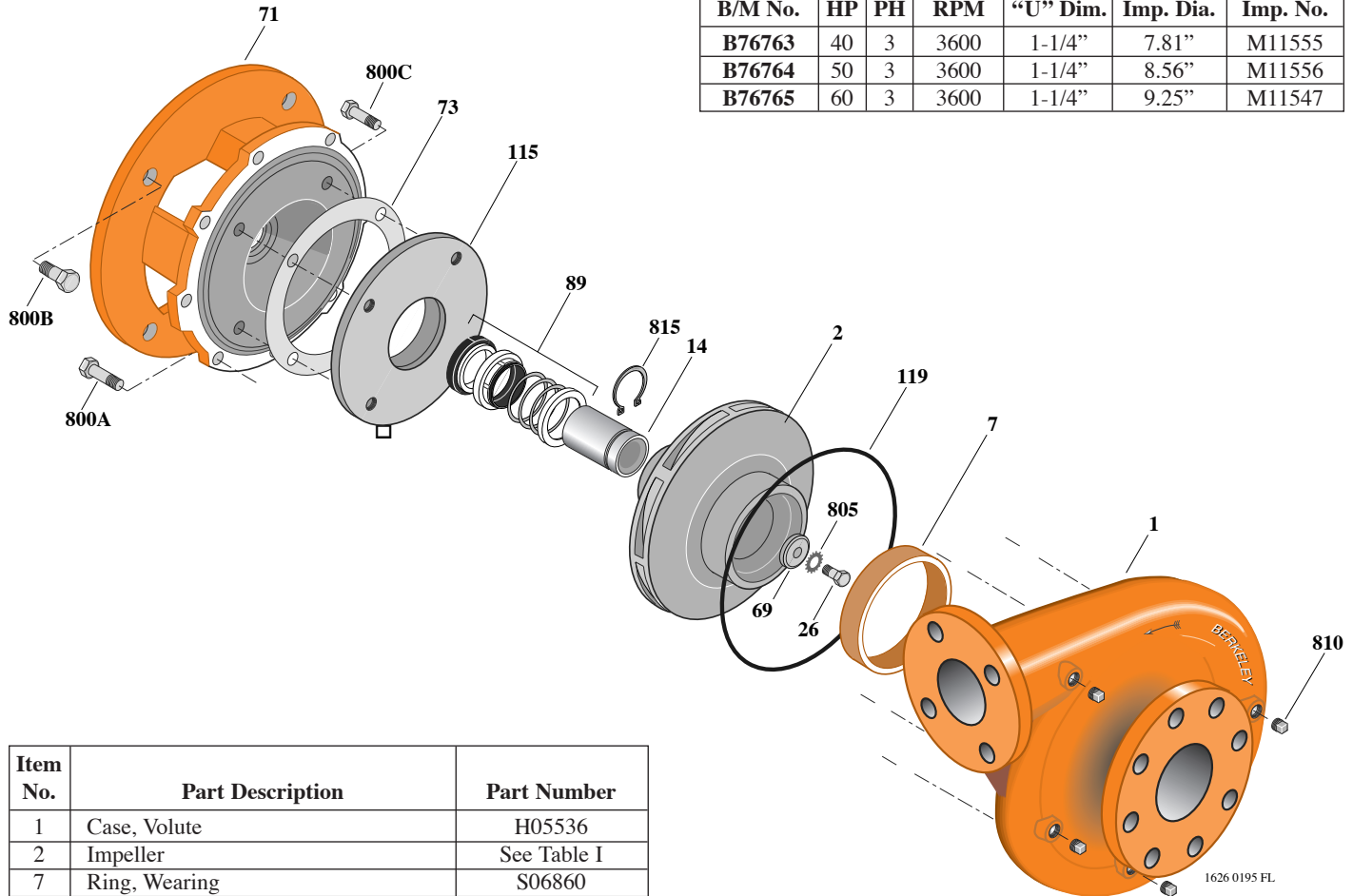

Item No.	Part Description	Part Number
1	Case, Volute	H05536
2	Impeller	See Table I
7	Ring, Wearing	S06860
14	Sleeve, Shaft	S18869
26	Screw, Impeller 1/2 - 13 x 1-1/2"	S23623
32	Key, 1/4 x 2-1/4" (See Note)	S23677
69	Washer, Impeller	S18117
71	Bracket	See Table II
73	Gasket, Balance Ring	S09943
89	Seal, Mechanical Shaft	S32015
105	Washer, Lock	S23038
115	Ring, Balance	L05262
119	O-Ring	S13760
800A	Capscrew, 1/2 - 13 x 1-1/4" (8 Req.)	S26914
800B	Capscrew, 5/8 - 11 x 1-1/2" (4 Req.)	S26999
800C	Capscrew, 3/8 - 16 x 3/4" (4 Req.)	S26824
805	Washer, Lock	S23038
810A	Plug, Pipe 1/4 NPT (4 Req.)	S23715
810B	Plug, Pipe 1/2 NPT	S23717
815	Ring, Retaining	S16767

TABLE II

HP	PH	Bracket No.	"AK" Fit	"U" Dim.	Motor Frame
40	3	L04628	12-1/2"	1-1/4"	286JM
50	3	L04628	12-1/2"	1-1/4"	324JM
60	3	L04628	12-1/2"	1-1/4"	326JM

NOTE: For an explanation of the tabulated material found on this page and for impeller key location, refer to *Supplement A* located at the beginning of this section.



TYPE "B" SINGLE STAGE CENTRIFUGAL PUMP Electric Motor Drive

Section	CC
Page	210.8
Date	January 1, 2004
Supersedes/New	

BRONZE IMPELLER

B3EPBLS

Flanged Case

Mechanical Shaft Seal Construction

TABLE I

B/M No.	HP	PH	RPM	"U" Dim.	Imp. Dia.	Imp. No.
B76766	75	3	3600	1-5/8"	10.12"	M11554

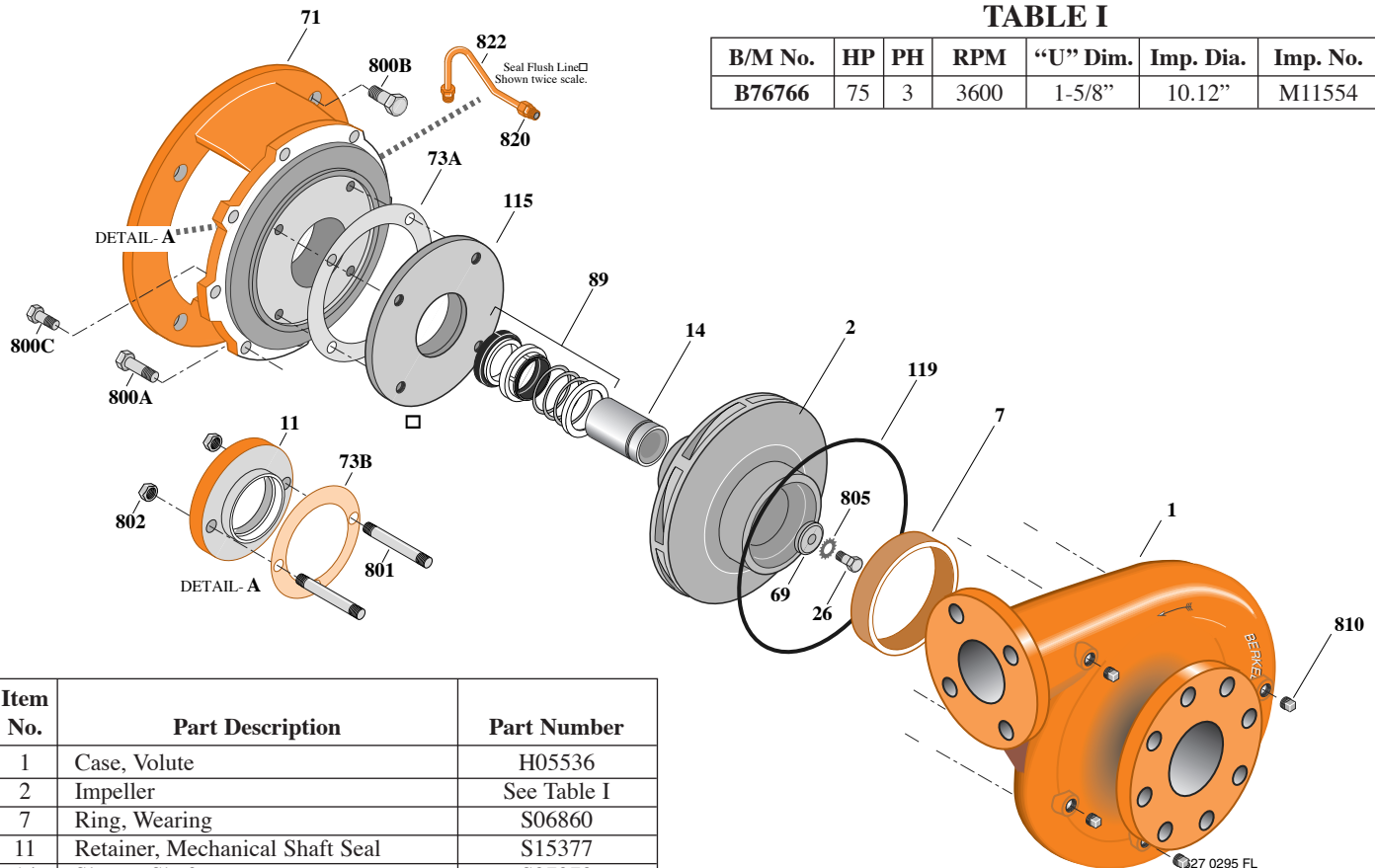

Item No.	Part Description	Part Number
1	Case, Volute	H05536
2	Impeller	See Table I
7	Ring, Wearing	S06860
11	Retainer, Mechanical Shaft Seal	S15377
14	Sleeve, Shaft	S07073
26	Screw, Impeller 1/2 - 13 x 1-1/2"	S23623
32	Key, 3/8 x 2-1/4" (See Note)	S23940
69	Washer, Impeller	S18801
71	Bracket	See Table II
73A	Gasket, Balance Ring	S09943
73B	Gasket, Seal Retainer	S15078
89	Seal, Mechanical Shaft	S32016
115	Ring, Balance	L03697
119	O-Ring	S13760
800A	Capscrew, 1/2 - 13 x 1-1/4" (8 Req.)	S26914
800B	Capscrew, 5/8 - 11 x 1-3/4" (4 Req.)	S27001
800C	Capscrew, 3/8 - 16 x 1" (4 Req.)	S26826
801	Stud, 3/8 - 16 x 2-1/2" (2 Req.)	S04438
802	Nut, 3/8 - 16 (2 Req.)	S23343
805	Washer, Lock	S23038
810A	Plug, Pipe 1/4 NPT (4 Req.)	S23715
810B	Plug, Pipe 1/2 NPT	S23717
820	Connector, Comp. Fitting (2 Req.)	S24013
822	Tubing, Copper	S20677
•	Plug, Pipe 1/8 NPT (At Seal Bore)	S23714

TABLE II

HP	PH	Bracket No.	"AK" Fit	"U" Dim.	Motor Frame
75	3	L06315	12-1/2"	1-5/8"	364JP

NOTE: For an explanation of the tabulated material found on this page and for impeller key location, refer to *Supplement A* located at the beginning of this section.