



# Type "B" Single Stage Centrifugal Pump Electric Motor Drive

Section	CC
Page	80.1
Date	July 1, 2011
Supersedes 1/1/04	

## CAST IRON IMPELLER

## B2ZPL

### Threaded Case (NPT)

### Packing Construction

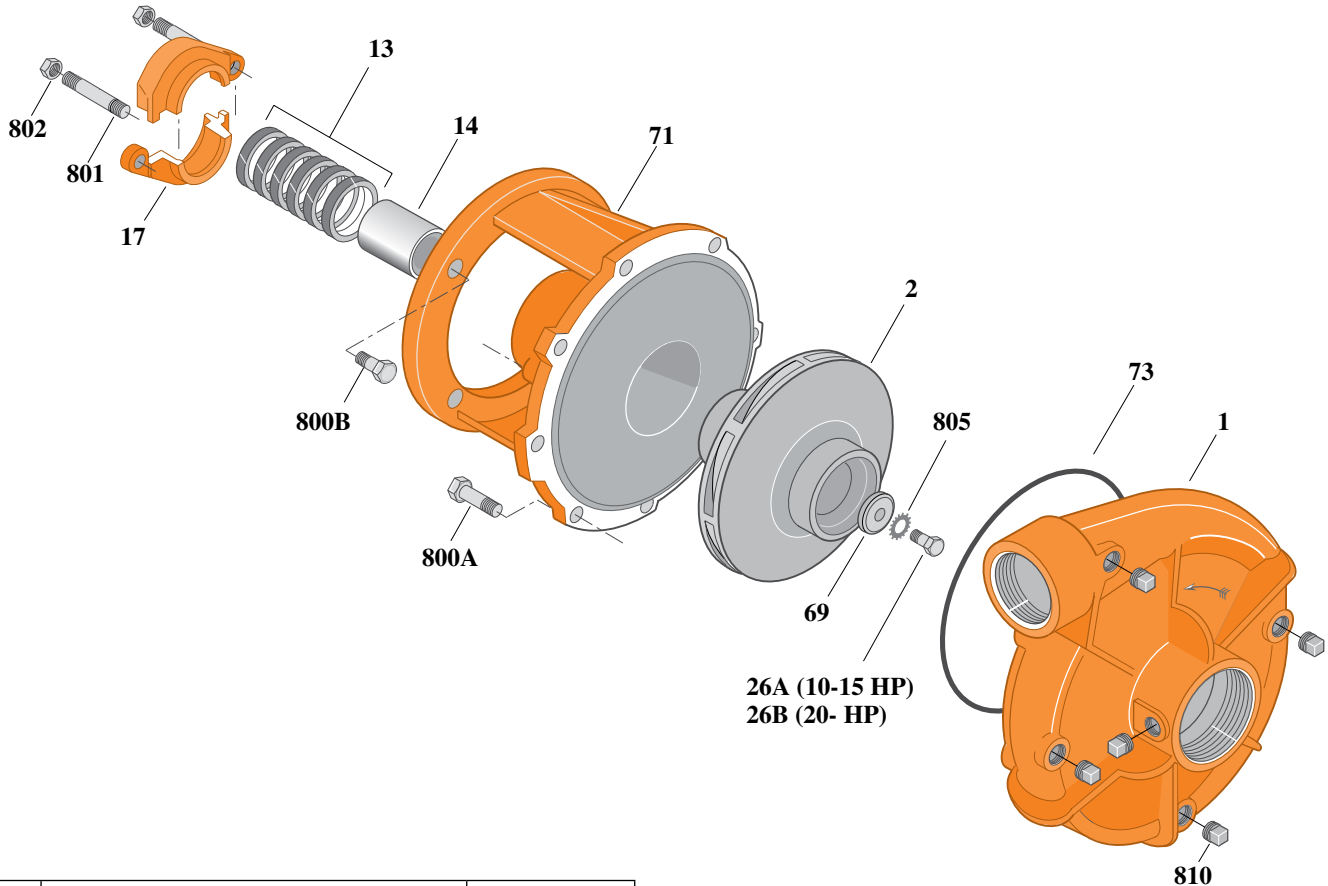

Item	Part Description	Part Number
1	Case, Volute	L01026
2	Impeller	See Table I
13	Rings, Packing (Set of 6)	S13470
14	Sleeve, Shaft	S05149L
17	Gland, Packing	B82470
26A	Screw, Impeller 1/2 -13 x 1-1/4"	S23621
26B	Screw, Impeller 1/2 -13 x 1"	S23619
32	Key, 1/4 x 2-1/4" (See Note 1)	S23677
69	Washer, Impeller	S06319
71	Bracket	See Table II
73	O-Ring (See Note 2)	M14943
800A	Capscrew, 3/8 - 16 x 1" (8 Req.)	S26826
800B	Capscrew, 1/2 - 13 x 1-1/2" (4 Req.)	S26916
801	Stud, 3/8 - 16 x 4" (2 Req.)	S08303
802	Nut, Hex 3/8 -16 (2 Req.)	S23343
805	Washer, Lock	S23038
810	Plug, Pipe 1/4 NPT (5 Req.)	S23715

**Table I**

B/M No.	HP	PH	RPM	"U" Dim.	Imp. Dia.	Imp. No.
B55571	10	1	3600	1-1/4"	7.56"	M07664
B55572	10	3	3600	1-1/4"	7.56"	M07664
B55573	15	3	3600	1-1/4"	8.31"	M07663
B55561	20	3	3600	1-1/4"	9.00"	M06933

**Table II**

HP	PH	Bracket No.	"AK" Fit	"U" Dim.	Motor Frame
10	1	L03827	8-1/2"	1-1/4"	215JP
10	3	L03827	8-1/2"	1-1/4"	213JP
15	3	L03827	8-1/2"	1-1/4"	215JP
20	3	L03827	8-1/2"	1-1/4"	254JP

**NOTE 1:** For an explanation of the tabulated material found on this page and for impeller key location, refer to *Supplement A* located at the beginning of this section.

**NOTE 2:** Also accepts gasket S05126 as replacement for o-ring. See *Supplement E* located at the beginning of this section.



# Type "B" Single Stage Centrifugal Pump Electric Motor Drive

Section	CC
Page	80.2
Date	July 1, 2011
Supersedes 1/1/04	

## CAST IRON IMPELLER B2ZPLS

**Threaded Case (NPT)**

**Mechanical Shaft Seal Construction**

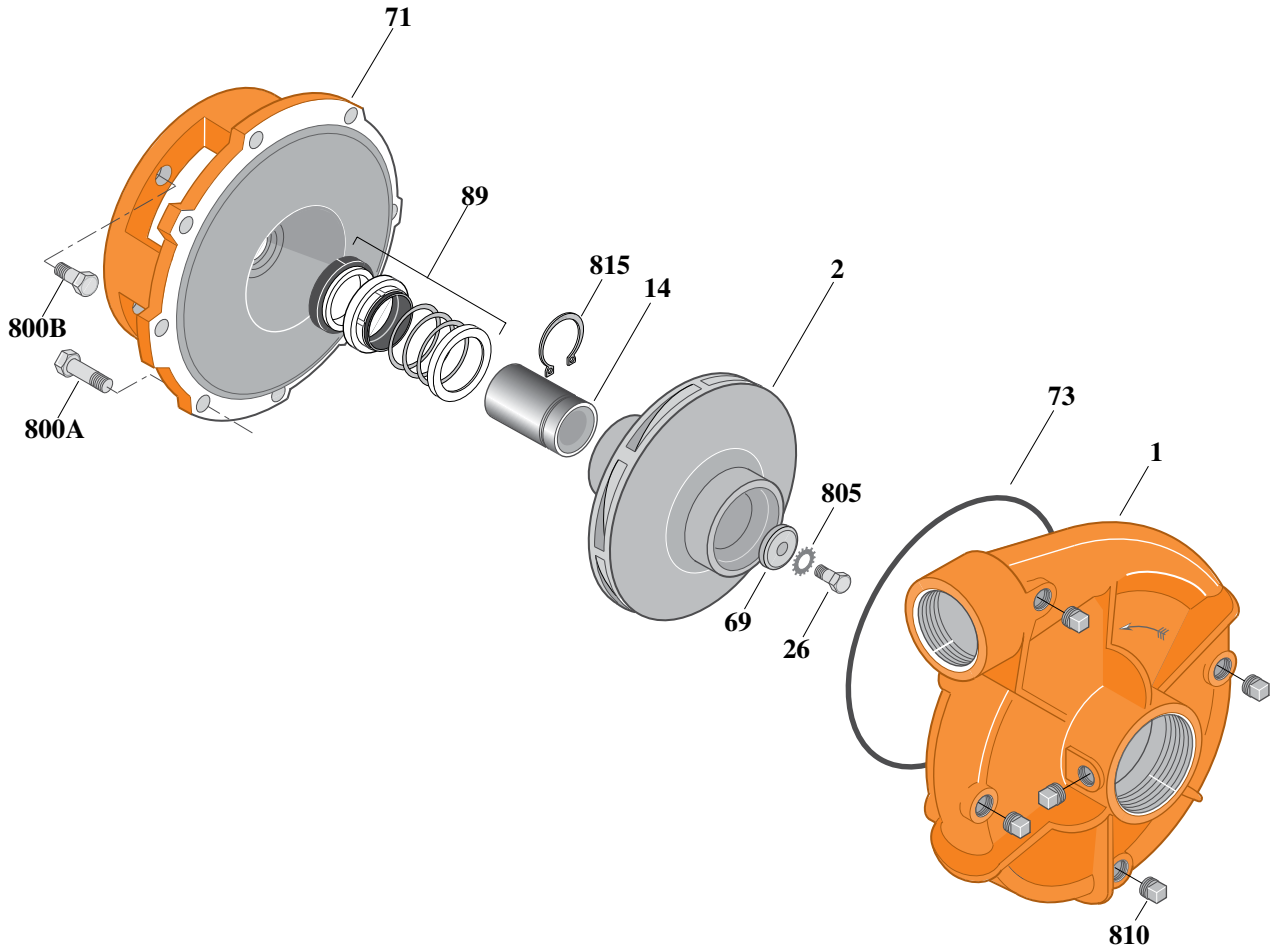

**Table I**

Item	Part Description	Part Number
1	Case, Volute	L01026
2	Impeller	See Table I
14	Sleeve, Shaft	S19310L
26	Screw, Impeller 3/8 - 16 x 1"	S23566
32	Key, 3/16 x 1-1/4" (See Note 1)	S34383
69	Washer, Impeller	S06314
71	Bracket	See Table II
73	O-Ring (See Note 2)	M14943
89	Seal, Mechanical Shaft	S32014
800A	Capscrew, 3/8 - 16 x 1" (8 Req.)	S26826
800B	Capscrew, 1/2 - 13 x 1" (4 Req.)	S26912
805	Washer, Lock	S23036
810	Plug, Pipe 1/4 NPT (5 Req.)	S23715
815	Ring, Retaining	S11207

B/M No.	HP	PH	RPM	"U" Dim.	Imp. Dia.	Imp. No.
B55562	10	1	3600	7/8"	7.56"	M07761
B55563	10	3	3600	7/8"	7.56"	M07761
B59742	10	1	3600	7/8"	7.56"	M07761
B77618	10	1	3600	7/8"	7.56"	M07761
B55564	15	3	3600	7/8"	8.31"	M07762

**Table II**

HP	PH	Bracket No.	"AK" Fit	"U" Dim.	Motor Frame
10	1	L05331	8-1/2"	7/8"	215JM
10	3	L05331	8-1/2"	7/8"	213JM
15	3	L05331	8-1/2"	7/8"	215JM

**NOTE 1:** For an explanation of the tabulated material found on this page and for impeller key location, refer to **Supplement A** located at the beginning of this section.

**NOTE 2:** Also accepts gasket S05126 as replacement for o-ring. See **Supplement E** located at the beginning of this section.



# Type "B" Single Stage Centrifugal Pump Electric Motor Drive

Section	CC
Page	80.3
Date	July 1, 2011
Supersedes 1/1/04	

## CAST IRON IMPELLERB2ZPLS

**Threaded Case (NPT)**

**Mechanical Shaft Seal Construction**

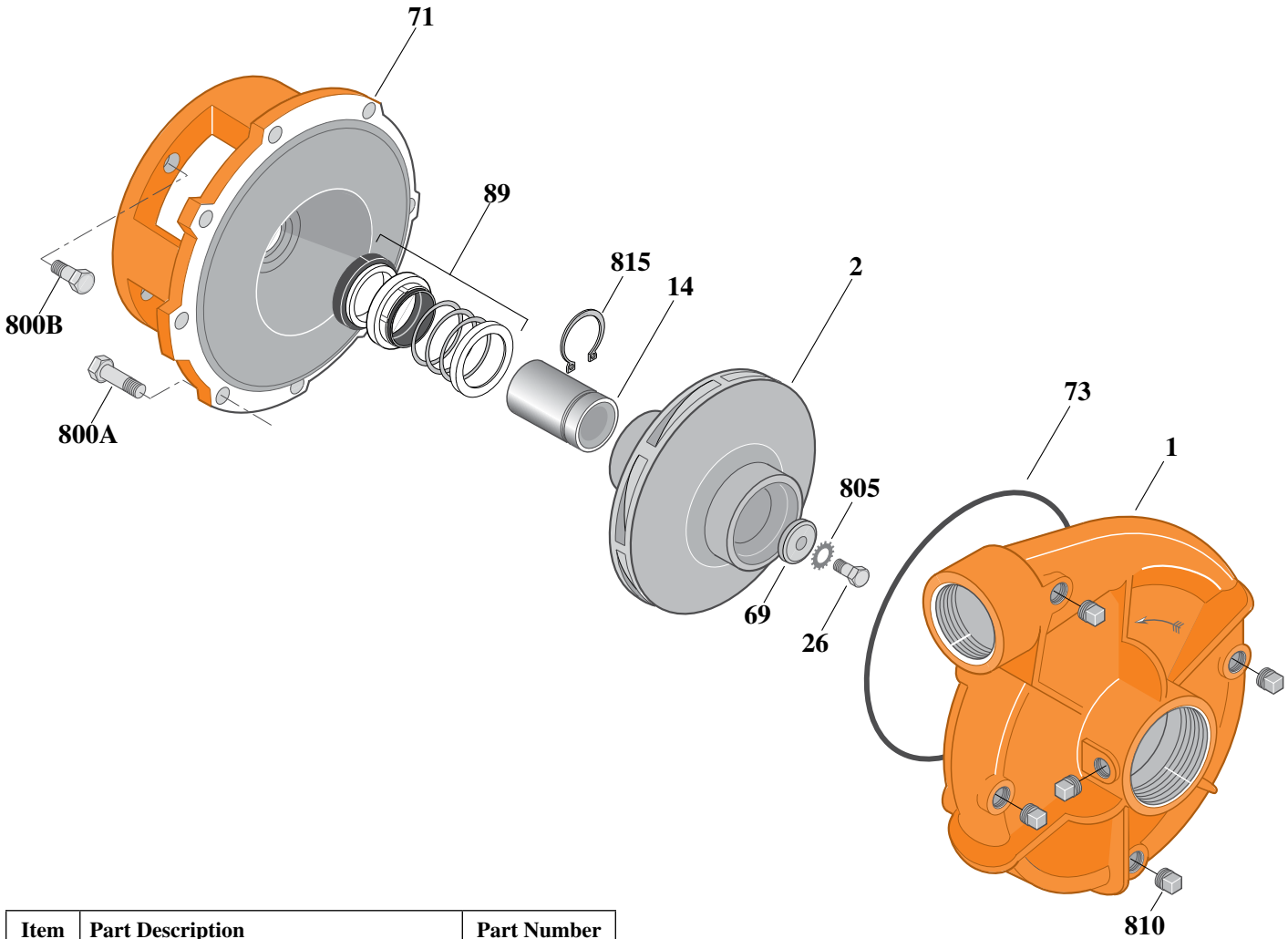

Item	Part Description	Part Number
1	Case, Volute	L01026
2	Impeller	See Table I
14	Sleeve, Shaft	S18869L
26	Screw, Impeller 1/2 - 13 x 1"	S23619
32	Key, 1/4 x 2-1/4" (See Note 1)	S23677
69	Washer, Impeller	S06319
71	Bracket	See Table II
73	O-Ring (See Note 2)	M14943
89	Seal, Mechanical Shaft	S32015
800A	Capscrew, 3/8 - 16 x 1" (8 Req.)	S26826
800B	Capscrew, 1/2 - 13 x 1" (4 Req.)	S26912
805	Washer, Lock	S23038
810	Plug, Pipe 1/4 NPT (5 Req.)	S23715
815	Ring, Retaining	S16767

**Table I**

B/M No.	HP	PH	RPM	"U" Dim.	Imp. Dia.	Imp. No.
B55565	20	3	3600	1-1/4"	9.00"	M06933

**Table II**

HP	PH	Bracket No.	"AK" Fit	"U" Dim.	Motor Frame
20	3	L04615	8-1/2"	1-1/4"	254JM

**NOTE 1:** For an explanation of the tabulated material found on this page and for impeller key location, refer to *Supplement A* located at the beginning of this section.

**NOTE 2:** Also accepts gasket S05126 as replacement for o-ring. See *Supplement E* located at the beginning of this section.



# Type "B" Single Stage Centrifugal Pump Electric Motor Drive

Section	CC
Page	80.4
Date	July 1, 2011
Supersedes 1/1/04	

## SILICON BRONZE IMPELLERB2ZPL

**Threaded Case (NPT)**

**Packing Construction**

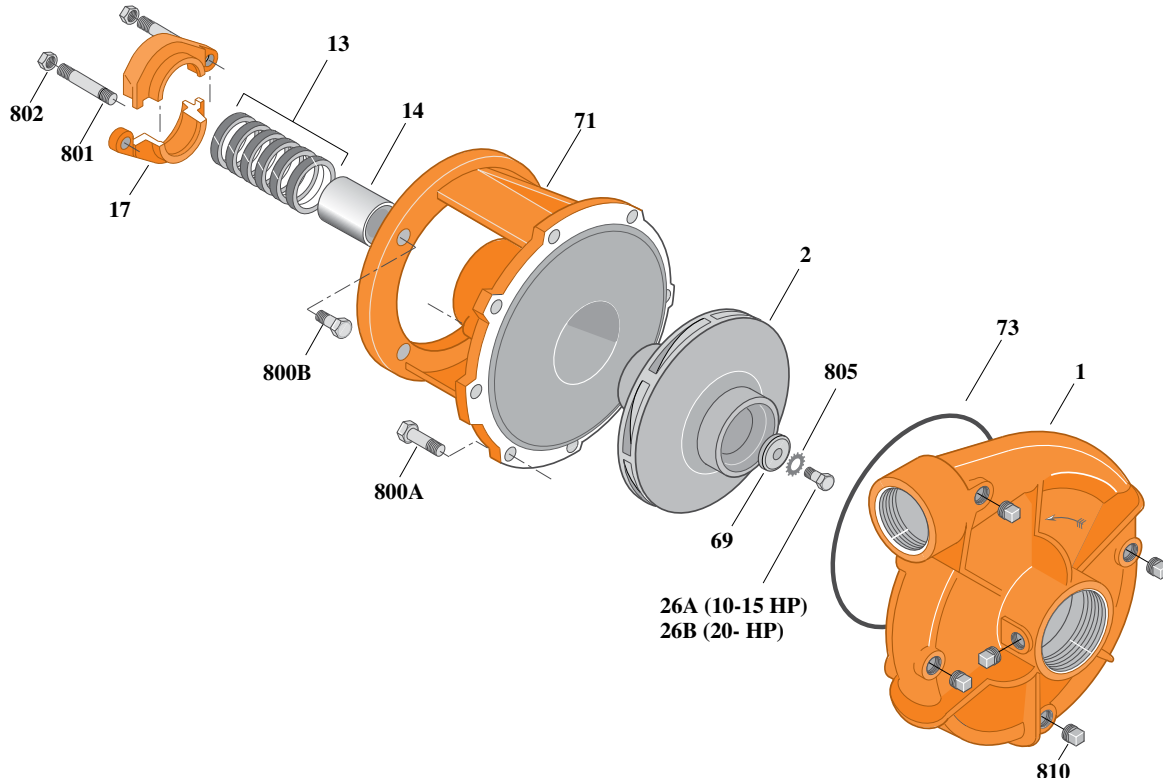

**Table I**

B/M No.	HP	PH	RPM	"U" Dim.	Imp. Dia.	Imp. No.
B66546	10	1	3600	1-1/4"	7.56"	L06638
B73881	10	1	3600	1-1/4"	7.56"	L08073
B66547	10	3	3600	1-1/4"	7.56"	L06638
B73882	10	3	3600	1-1/4"	7.56"	L08073
B66515	15	3	3600	1-1/4"	8.31"	L06637
B73886	15	3	3600	1-1/4"	8.31"	L08074
B66516	20	3	3600	1-1/4"	9.00"	L06664
B73890	20	3	3600	1-1/4"	9.00"	L08075

**Table II**

HP	PH	Bracket No.	"AK" Fit	"U" Dim.	Motor Frame
10	1	L03827	8-1/2"	1-1/4"	215JP
10	3	L03827	8-1/2"	1-1/4"	213JP
15	3	L03827	8-1/2"	1-1/4"	215JP
20	3	L03827	8-1/2"	1-1/4"	254JP

Item	Part Description	Part Number
1	Case, Volute	L01026
2	Impeller	See Table I
13	Rings, Packing (Set of 6)	S13470
14	Sleeve, Shaft	S05149L
17	Gland, Packing	B82470
26A	Screw, Impeller 1/2 -13 x 1-1/4"	S23621
26B	Screw, Impeller 1/2 -13 x 1"	S23619
32	Key, 1/4 x 2-1/4" (See Note 1)	S23677
69	Washer, Impeller	S06319
71	Bracket	See Table II
73	O-Ring (See Note 2)	M14943
800A	Capscrew, 3/8 - 16 x 1" (8 Req.)	S26826
800B	Capscrew, 1/2 - 13 x 1-1/2" (4 Req.)	S26916
801	Stud, 3/8- 16 x 4" (2 Req.)	S08303
802	Nut, Hex 3/8 -16 (2 Req.)	S23343
805	Washer, Lock	S23038
810	Plug, Pipe 1/4 NPT (5 Req.)	S23715

**NOTE 1:** For an explanation of the tabulated material found on this page and for impeller key location, refer to **Supplement A** located at the beginning of this section.

**NOTE 2:** Also accepts gasket S05126 as replacement for o-ring. See **Supplement E** located at the beginning of this section.



# Type "B" Single Stage Centrifugal Pump Electric Motor Drive

Section	CC
Page	80.5
Date	July 1, 2011
Supersedes 1/1/04	

## SILICON BRONZE IMPELLERB2ZPLS

**Threaded Case (NPT)**

**Mechanical Shaft Seal Construction**

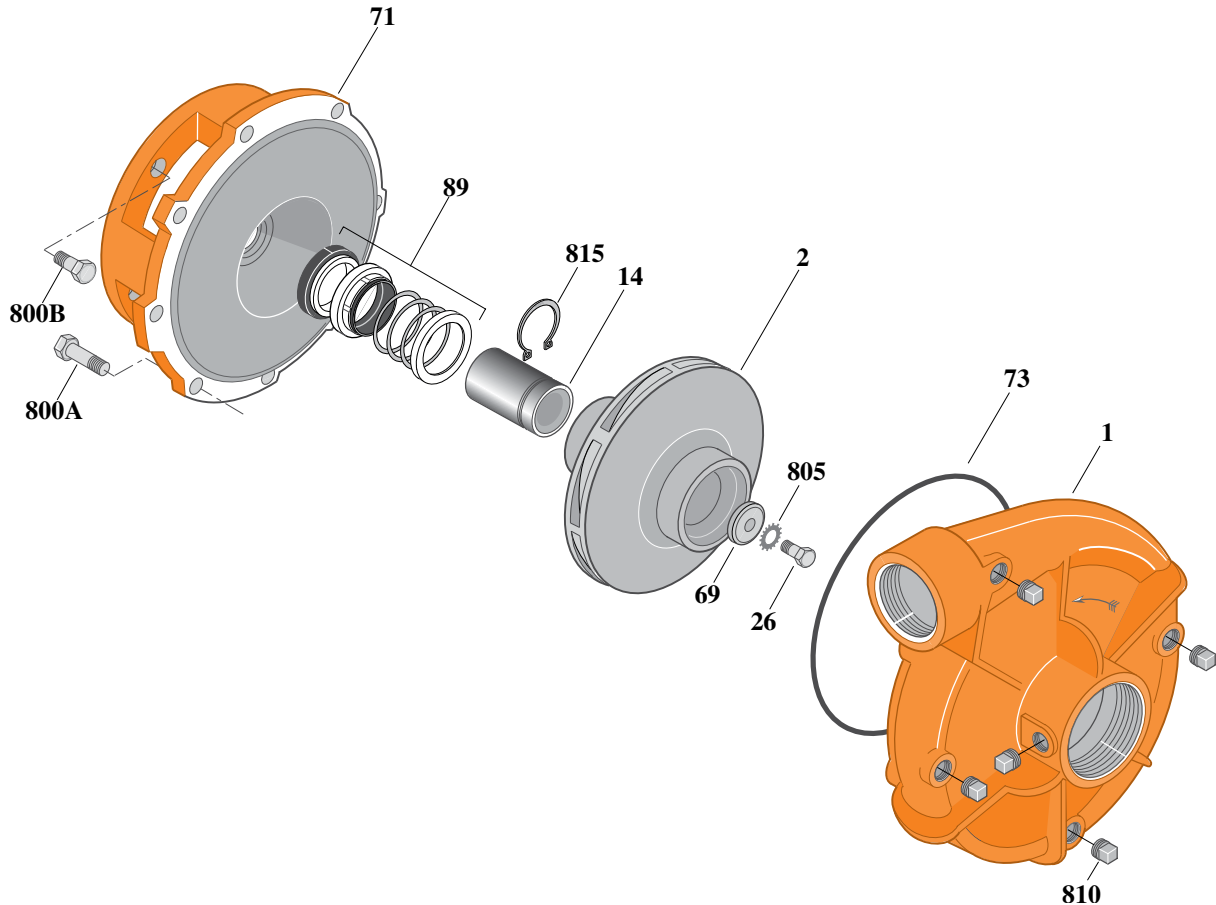

**Table I**

B/M No.	HP	PH	RPM	"U" Dim.	Imp. Dia.	Imp. No.
B73894	10	1	3600	7/8"	7.56"	L08076
B73895	10	3	3600	7/8"	7.56"	L08076
B73899	15	3	3600	7/8"	8.31"	L08077
B66823	<i>These B/M Numbers Are No Longer Available. See Above For Current Models</i>					
B66824						
B66828						

Item	Part Description	Part Number
1	Case, Volute	L01026
2	Impeller	See Table I
14	Sleeve, Shaft	S19310L
26	Screw, Impeller 3/8 - 16 x 1"	S23566
32	Key, 3/16 x 1-1/4" (See Note 1)	S34383
69	Washer, Impeller	S06314
71	Bracket	See Table II
73	O-Ring (See Note 2)	M14943
89	Seal, Mechanical Shaft	S32014
800A	Capscrew, 3/8 - 16 x 1" (8 Req.)	S26826
800B	Capscrew, 1/2 - 13 x 1" (4 Req.)	S26912
805	Washer, Lock	S23036
810	Plug, Pipe 1/4 NPT (5 Req.)	S23715
815	Ring, Retaining	S11207

**Table II**

HP	PH	Bracket No.	"AK" Fit	"U" Dim.	Motor Frame
10	1	L05331	8-1/2"	7/8"	215JM
10	3	L05331	8-1/2"	7/8"	213JM
15	3	L05331	8-1/2"	7/8"	215JM

**NOTE 1:** For an explanation of the tabulated material found on this page and for impeller key location, refer to *Supplement A* located at the beginning of this section.

**NOTE 2:** Also accepts gasket S05126 as replacement for o-ring. See *Supplement E* located at the beginning of this section.



# Type "B" Single Stage Centrifugal Pump Electric Motor Drive

Section	CC
Page	80.6
Date	July 1, 2011
Supersedes 1/1/04	

## SILICON BRONZE IMPELLER B2ZPLS

Threaded Case (NPT)

Mechanical Shaft Seal Construction

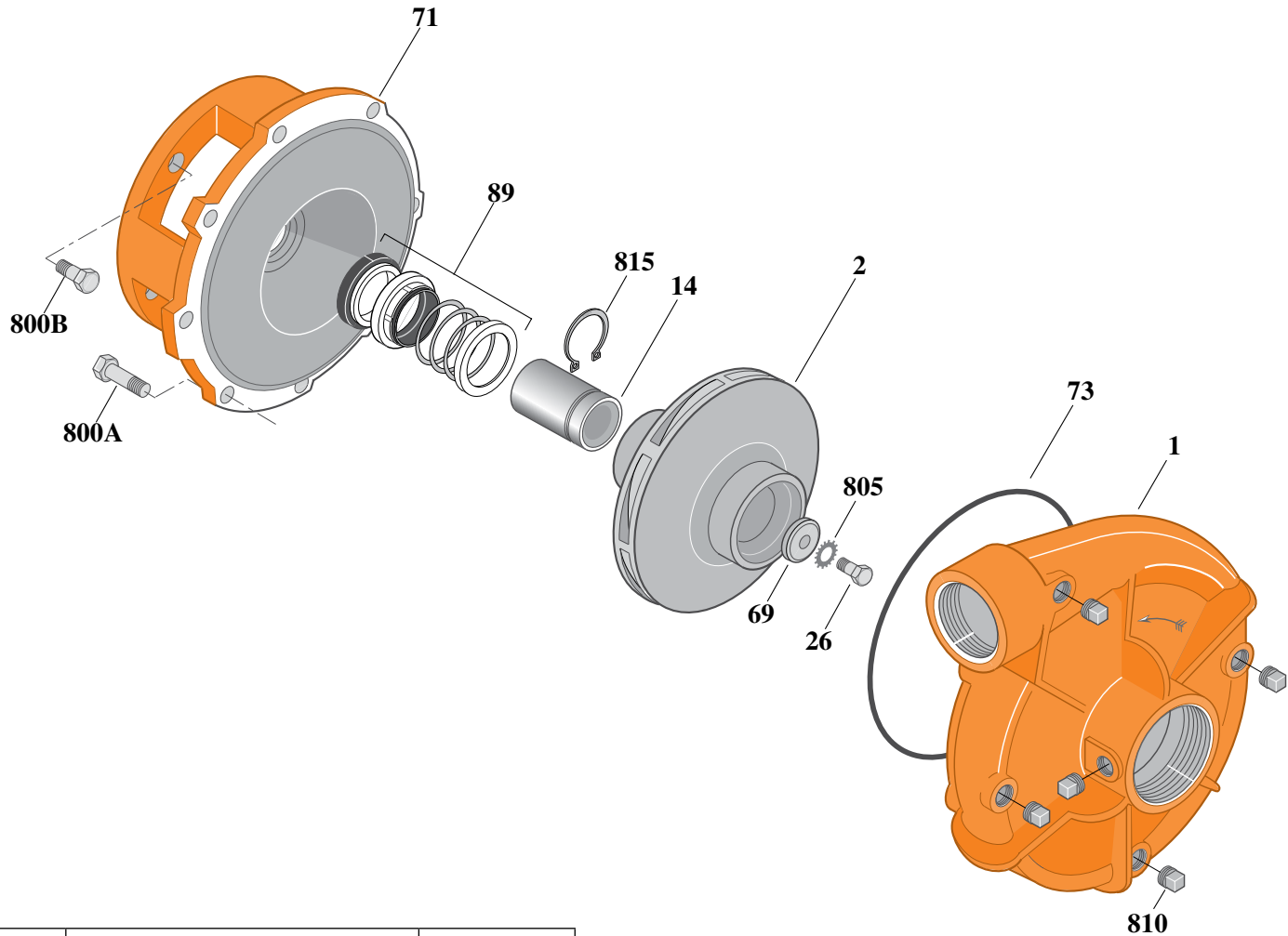

Item	Part Description	Part Number
1	Case, Volute	L01026
2	Impeller	See Table I
14	Sleeve, Shaft	S18869L
26	Screw, Impeller 1/2 - 13 x 1"	S23619
32	Key, 1/4 x 2-1/4" (See Note 1)	S23677
69	Washer, Impeller	S06319
71	Bracket	See Table II
73	O-Ring (See Note 2)	M14943
89	Seal, Mechanical Shaft	S32015
800A	Capscrew, 3/8 - 16 x 1" (8 Req.)	S26826
800B	Capscrew, 1/2 - 13 x 1" (4 Req.)	S26912
805	Washer, Lock	S23038
810	Plug, Pipe 1/4 NPT (5 Req.)	S23715
815	Ring, Retaining	S16767

**Table I**

B/M No.	HP	PH	RPM	"U" Dim.	Imp. Dia.	Imp. No.
B66517	<i>No Longer Available. See Below For Current Model.</i>					
B73901	20	3	3600	1-1/4"	9.00"	L08075

**Table II**

HP	PH	Bracket No.	"AK" Fit	"U" Dim.	Motor Frame
20	3	L04615	8-1/2"	1-1/4"	254JM

**NOTE 1:** For an explanation of the tabulated material found on this page and for impeller key location, refer to **Supplement A** located at the beginning of this section.

**NOTE 2:** Also accepts gasket S05126 as replacement for o-ring. See **Supplement E** located at the beginning of this section.





# TYPE "B" SINGLE STAGE CENTRIFUGAL PUMP Electric Motor Drive

Section	CC
Page	80.7
Date	September 1, 1997
Supersedes/New	

## SILICON BRONZE IMPELLER

## B2ZPL

**Threaded Case (NPT)**

**Packing Construction**

**TABLE I**

B/M No.	HP	PH	RPM	"U" Dim.	Imp. Dia.	Imp. No.
<b>B73881</b>	10	1	3600	1-1/4"	7.56"	L08073
<b>B73882</b>	10	3	3600	1-1/4"	7.56"	L08073
<b>B73886</b>	15	3	3600	1-1/4"	8.31"	L08074
<b>B73890</b>	20	3	3600	1-1/4"	9.00"	L08075

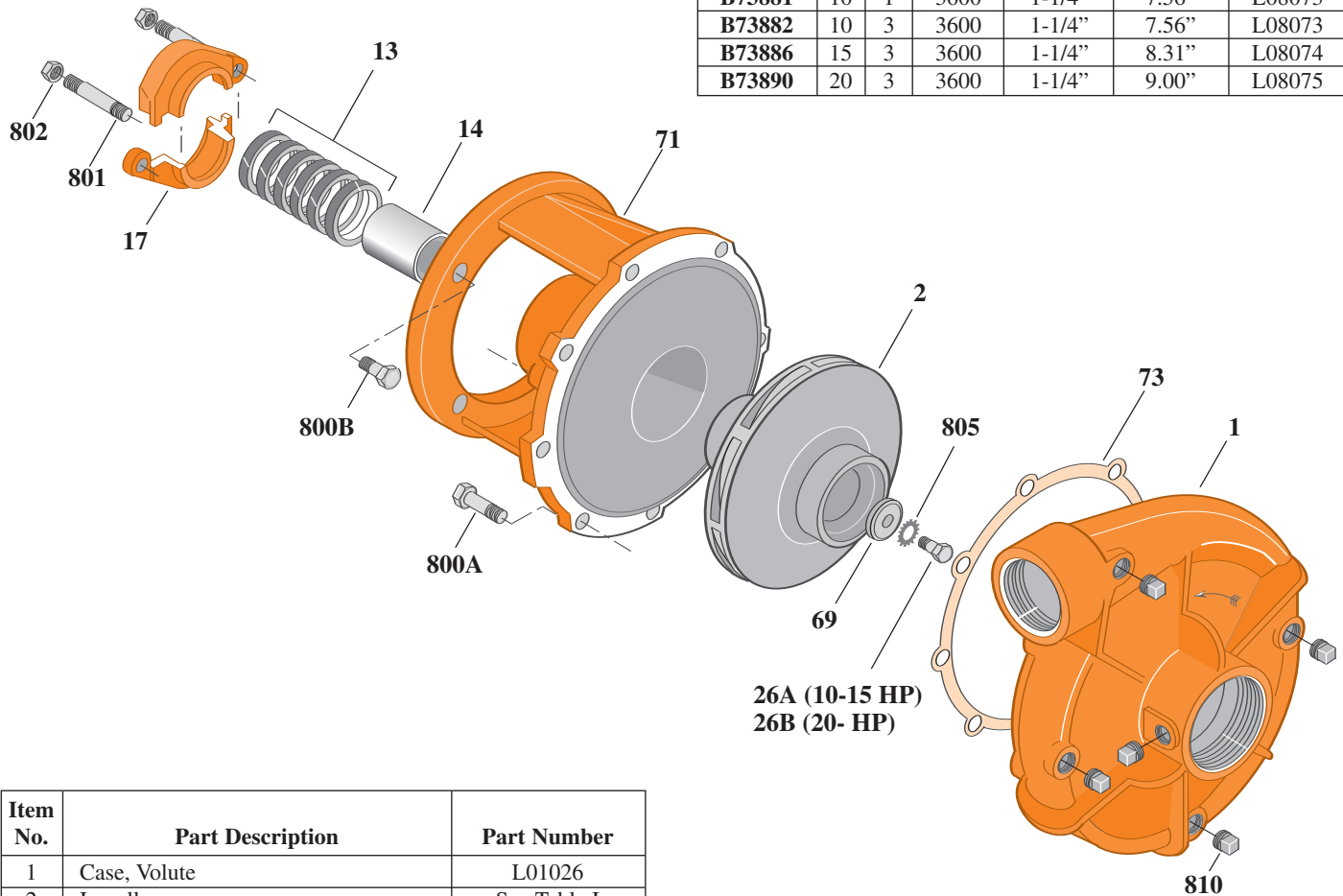

Item No.	Part Description	Part Number
1	Case, Volute	L01026
2	Impeller	See Table I
13	Rings, Packing (Set of 6)	S13470
14	Sleeve, Shaft	S05149
17	Gland, Packing	S12034
26A	Screw, Impeller 1/2 -13 x 1-1/4"	S23621
26B	Screw, Impeller 1/2 -13 x 1"	S23619
32	Key, 1/4 x 2-1/4" (See Note)	S23677
69	Washer, Impeller	S06319
71	Bracket	See Table II
73	Gasket, Volute	S05126
800A	Capscrew, 3/8 - 16 x 1" (8 Req.)	S26826
800B	Capscrew, 1/2 - 13 x 1-1/2" (4 Req.)	S26916
801	Stud, 3/8- 16 x 4" (2 Req.)	S08303
802	Nut, Hex 3/8 -16 (2 Req.)	S23343
805	Washer, Lock	S23038
810	Plug, Pipe 1/4" NPT (5 Req.)	S23715

**TABLE II**

HP	PH	Bracket No.	"AK" Fit	"U" Dim.	Motor Frame
10	1	L03827	8-1/2"	1-1/4"	215JP
10	3	L03827	8-1/2"	1-1/4"	213JP
15	3	L03827	8-1/2"	1-1/4"	215JP
20	3	L03827	8-1/2"	1-1/4"	254JP

**NOTE:** For an explanation of the tabulated material found on this page and for impeller key location, refer to *Supplement A* located at the beginning of this section.



# Type "B" Single Stage Centrifugal Pump Electric Motor Drive

Section	CC
Page	80.8
Date	July 1, 2011
Supersedes 1/1/04	

## SILICON BRONZE IMPELLERB2ZPL

### Flanged Case

### Packing Construction

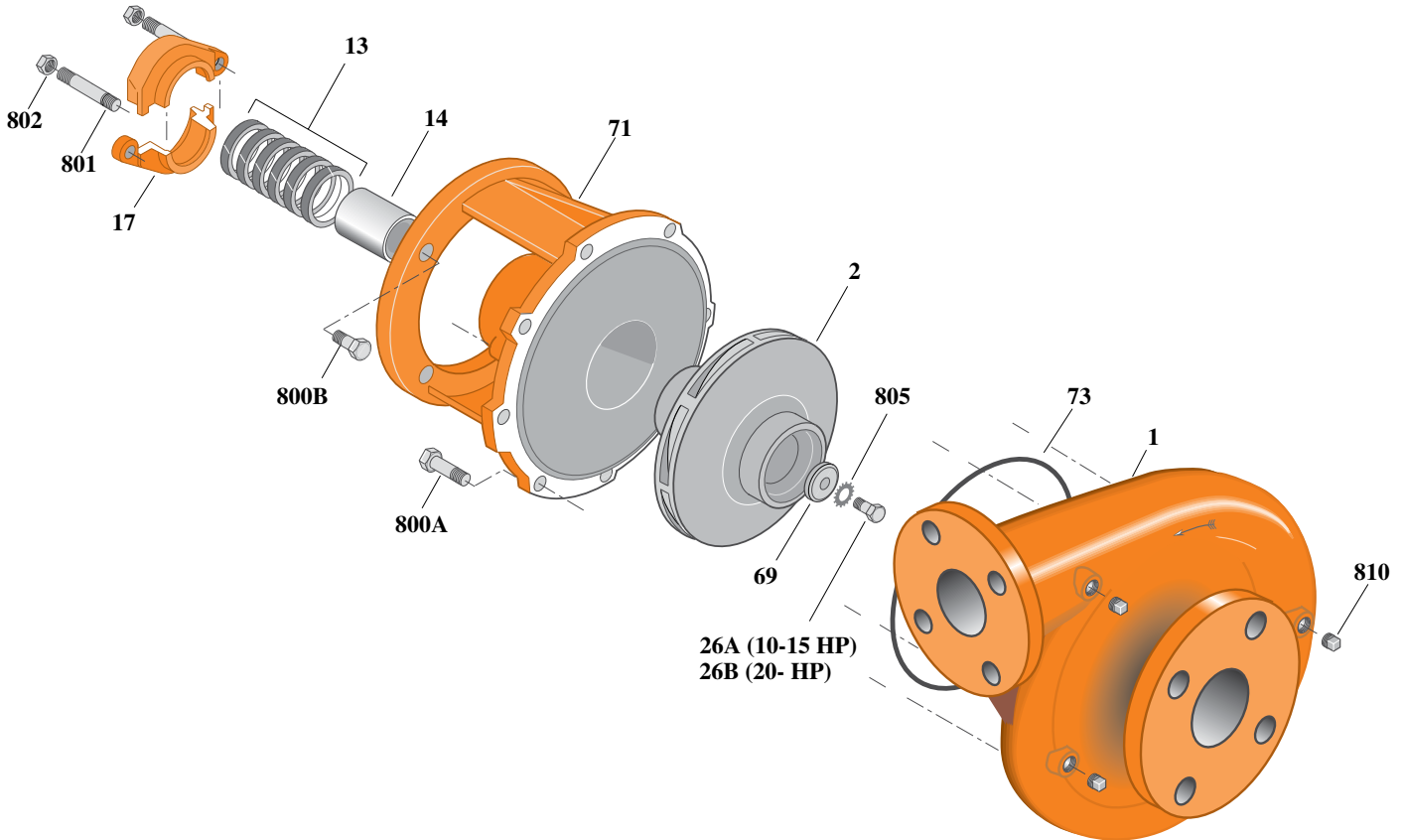

Item	Part Description	Part Number
1	Case, Volute	H05524
2	Impeller	See Table I
13	Rings, Packing (Set of 6)	S13470
14	Sleeve, Shaft	S05149L
17	Gland, Packing	B82470
26A	Screw, Impeller 1/2 -13 x 1-1/4"	S23621
26B	Screw, Impeller 1/2 -13 x 1"	S23619
32	Key, 1/4 x 2-1/4" (See Note 1)	S23677
69	Washer, Impeller	S06319
71	Bracket	See Table II
73	O-Ring (See Note 2)	M14943
800A	Capscrew, 3/8 - 16 x 1" (8 Req.)	S26826
800B	Capscrew, 1/2 - 13 x 1-1/2" (4 Req.)	S26916
801	Stud, 3/8- 16 x 4" (2 Req.)	S08303
802	Nut, Hex 3/8 -16 (2 Req.)	S23343
805	Washer, Lock	S23038
810	Plug, Pipe 1/4" NPT (4 Req.)	S23715

**Table I**

B/M No.	HP	PH	RPM	"U" Dim.	Imp. Dia.	Imp. No.
B74476	10	1	3600	1-1/4"	7.56"	L08073
B74477	10	3	3600	1-1/4"	7.56"	L08073
B74480	15	3	3600	1-1/4"	8.31"	L08074
B74483	20	3	3600	1-1/4"	9.00"	L08075

**Table II**

HP	PH	Bracket No.	"AK" Fit	"U" Dim.	Motor Frame
10	1	L03827	8-1/2"	1-1/4"	215JP
10	3	L03827	8-1/2"	1-1/4"	213JP
15	3	L03827	8-1/2"	1-1/4"	215JP
20	3	L03827	8-1/2"	1-1/4"	254JP

**NOTE 1:** For an explanation of the tabulated material found on this page and for impeller key location, refer to *Supplement A* located at the beginning of this section.

**NOTE 2:** Also accepts gasket S05126 as replacement for o-ring. See *Supplement E* located at the beginning of this section.





# TYPE "B" SINGLE STAGE CENTRIFUGAL PUMP Electric Motor Drive

Section	CC
Page	80.9
Date	September 1, 1997
Supersedes/New	

## SILICON BRONZE IMPELLER

## B2ZPLS

### Threaded Case (NPT)

### Mechanical Shaft Seal Construction

TABLE I

B/M No.	HP	PH	RPM	"U" Dim.	Imp. Dia.	Imp. No.
B73894	10	1	3600	7/8"	7.56"	L08076
B73895	10	3	3600	7/8"	7.56"	L08076
B73899	15	3	3600	7/8"	8.31"	L08077

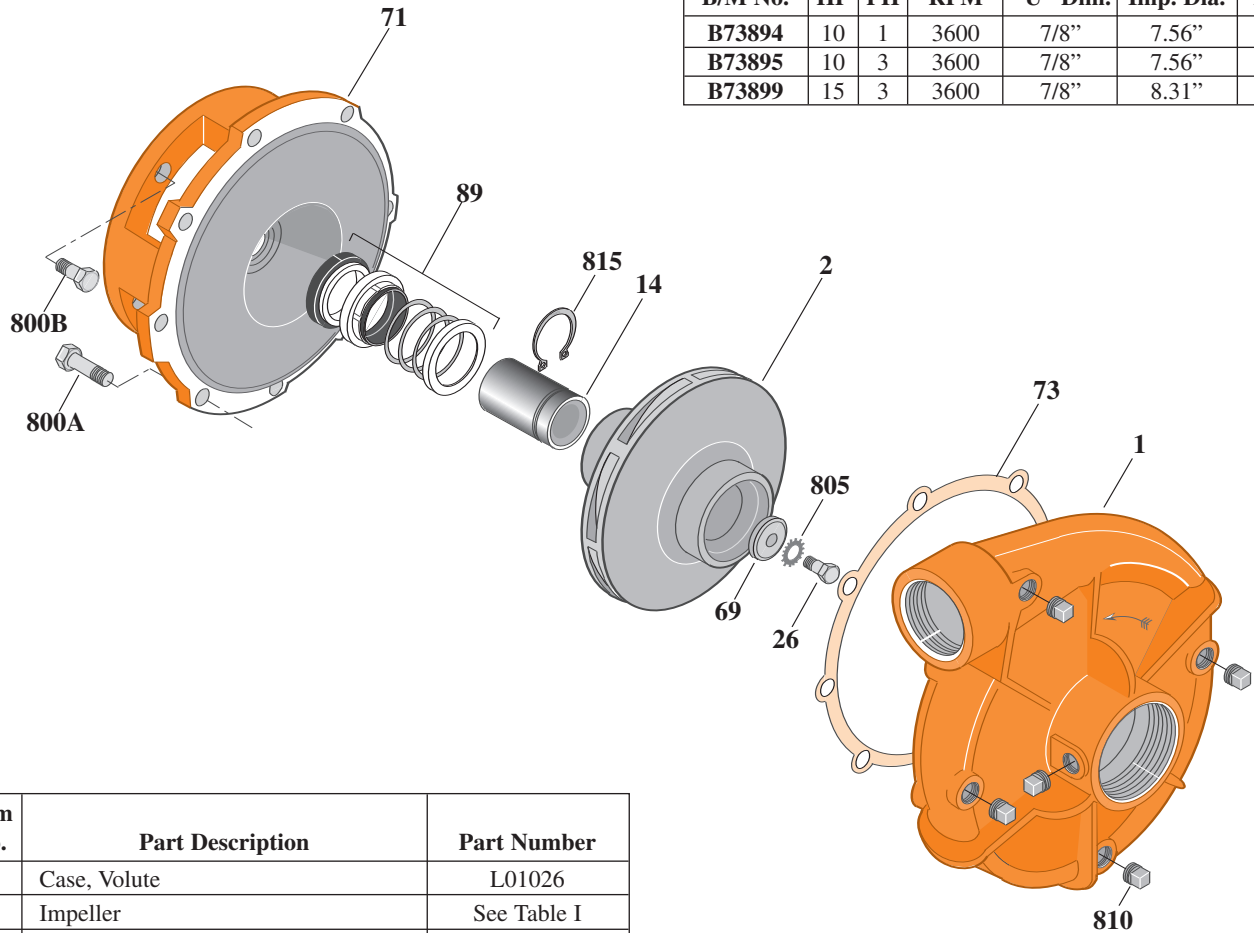

1497 0195

Item No.	Part Description	Part Number
1	Case, Volute	L01026
2	Impeller	See Table I
14	Sleeve, Shaft	S19310
26	Screw, Impeller 3/8 - 16 x 1"	S23566
32	Key, 3/16 x 1-1/4" (See Note)	S34383
69	Washer, Impeller	S06314
71	Bracket	See Table II
73	Gasket, Volute	S05126
89	Seal, Mechanical Shaft	S32014
800A	Capscrew, 3/8 - 16 x 1" (8 Req.)	S26826
800B	Capscrew, 1/2 - 13 x 1" (4 Req.)	S26912
805	Washer, Lock	S23036
810	Plug, Pipe 1/4" NPT (5 Req.)	S23715
815	Ring, Retaining	S11207
•	Plug, Pipe 1/8" NPT (In Bracket)	S23714

• Not illustrated.

TABLE II

HP	PH	Bracket No.	"AK" Fit	"U" Dim.	Motor Frame
10	1	L05331	8-1/2"	7/8"	215JM
10	3	L05331	8-1/2"	7/8"	213JM
15	3	L05331	8-1/2"	7/8"	215JM

**NOTE:** For an explanation of the tabulated material found on this page and for impeller key location, refer to *Supplement A* located at the beginning of this section.

**NOTE:** For seal flush line details, see *Supplement D*.



# TYPE "B" SINGLE STAGE CENTRIFUGAL PUMP Electric Motor Drive

Section	CC
Page	80.10
Date	September 1, 1997
Supersedes/New	

## SILICON BRONZE IMPELLER

## B2ZPLS

### Threaded Case (NPT)

### Mechanical Shaft Seal Construction

**TABLE I**

B/M No.	HP	PH	RPM	"U" Dim.	Imp. Dia.	Imp. No.
B73901	20	3	3600	1-1/4"	9.00"	L08075

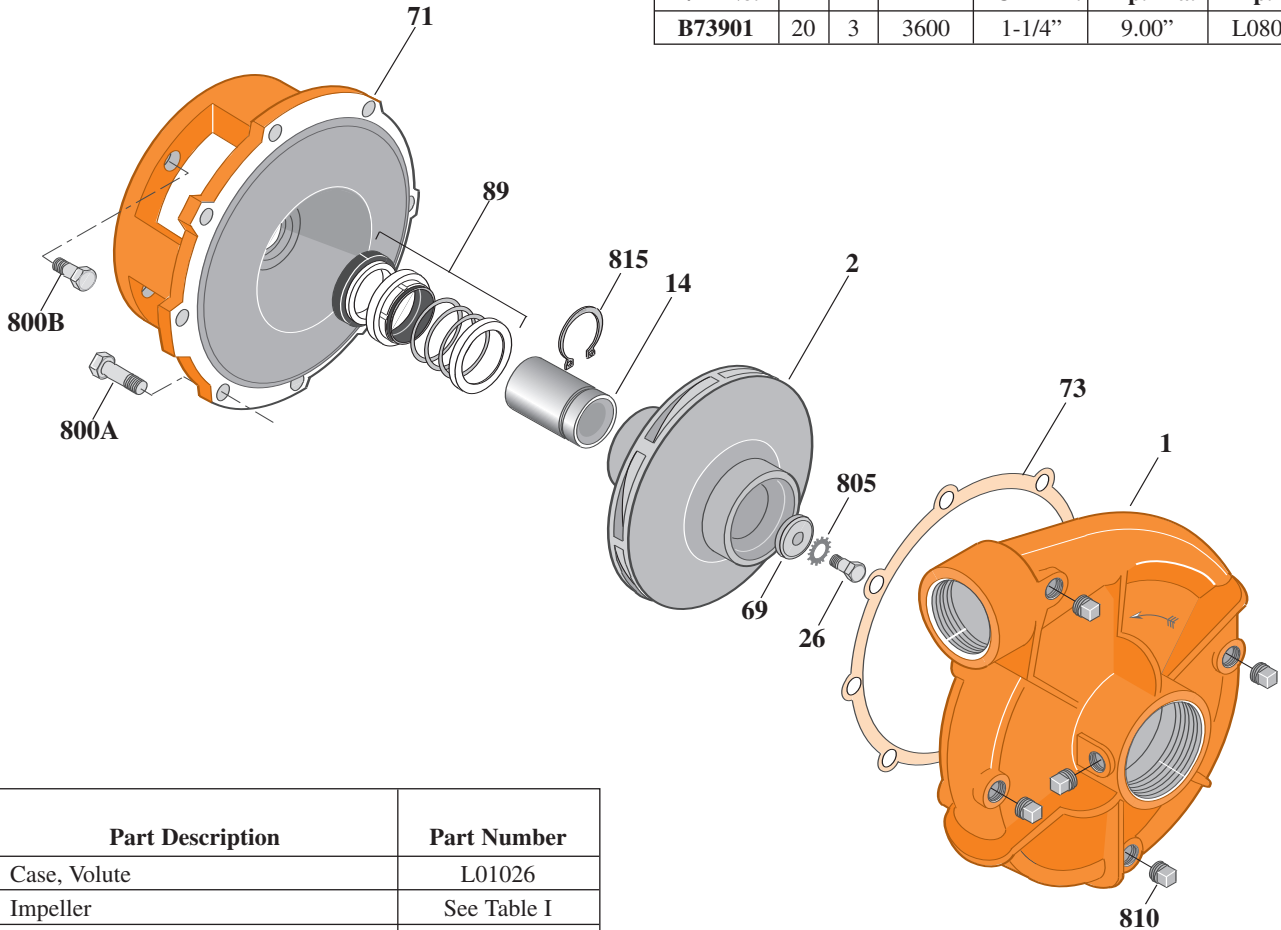

1607 0195

Item No.	Part Description	Part Number
1	Case, Volute	L01026
2	Impeller	See Table I
14	Sleeve, Shaft	S18869
26	Screw, Impeller 1/2 - 13 x 1"	S23619
32	Key, 1/4 x 2-1/4" (See Note)	S23677
69	Washer, Impeller	S06319
71	Bracket	See Table II
73	Gasket, Volute	S05126
89	Seal, Mechanical Shaft	S32015
800A	Capscrew, 3/8 - 16 x 1" (8 Req.)	S26826
800B	Capscrew, 1/2 - 13 x 1" (4 Req.)	S26912
805	Washer, Lock	S23038
810	Plug, Pipe 1/4" NPT (5 Req.)	S23715
815	Ring, Retaining	S16767
•	Plug, Pipe 1/8" NPT (In Bracket)	S23714

• Not illustrated.

**TABLE II**

HP	PH	Bracket No.	"AK" Fit	"U" Dim.	Motor Frame
20	3	L04615	8-1/2"	1-1/4"	254JM

**NOTE:** For an explanation of the tabulated material found on this page and for impeller key location, refer to *Supplement A* located at the beginning of this section.

**NOTE:** For seal flush line details, see *Supplement D*.



# Type "B" Single Stage Centrifugal Pump Electric Motor Drive

Section	CC
Page	80.11
Date	July 1, 2011
Supersedes 1/1/04	

## SILICON BRONZE IMPELLER

## B2ZPLS

### Flanged Case

### Mechanical Shaft Seal Construction

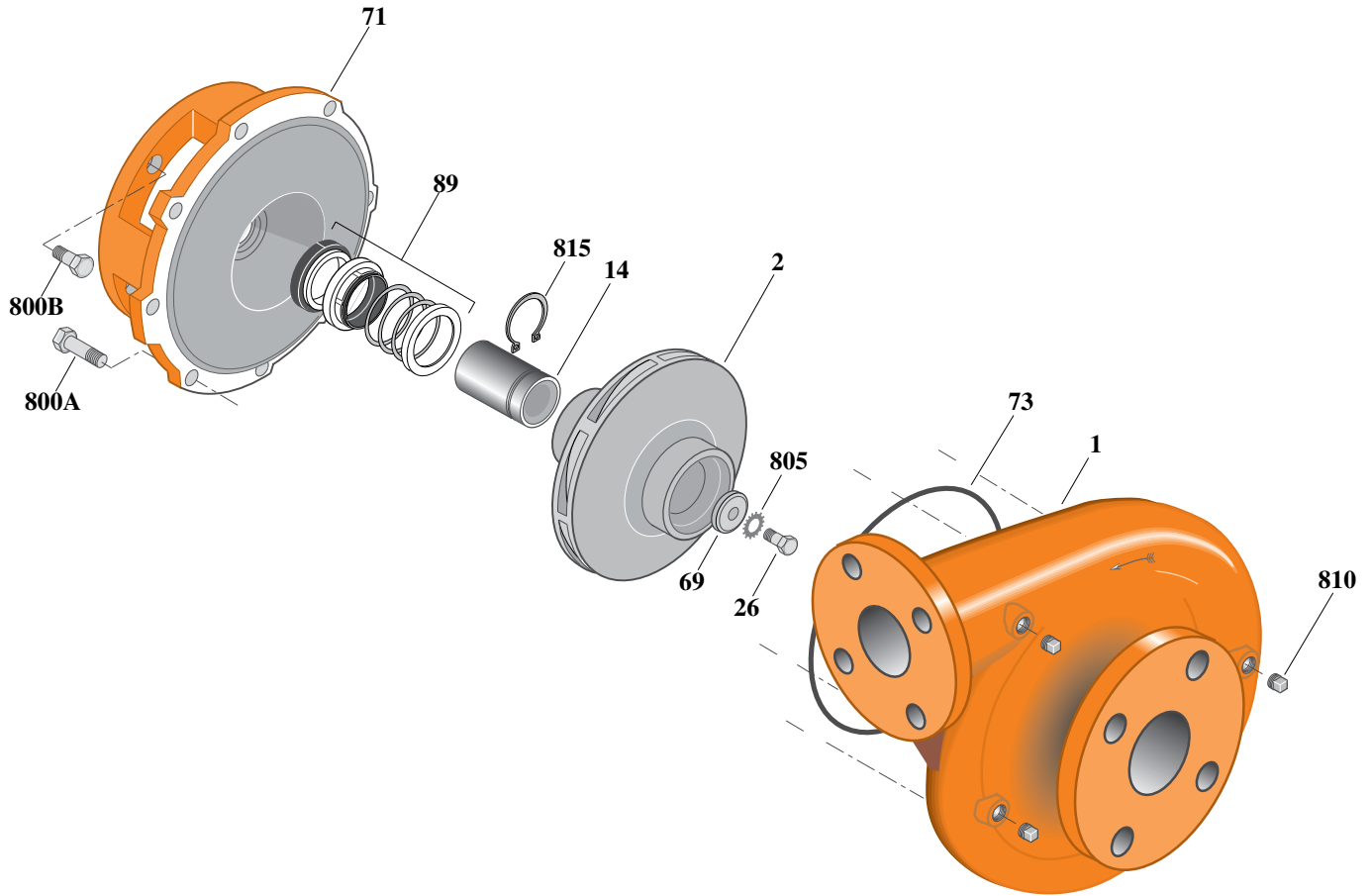

Item	Part Description	Part Number
1	Case, Volute	H05524
2	Impeller	See Table I
14	Sleeve, Shaft	S19310L
26	Screw, Impeller 3/8 - 16 x 1"	S23566
32	Key, 3/16 x 1-1/4" (See Note 1)	S34383
69	Washer, Impeller	S06314
71	Bracket	See Table II
73	O-Ring (See Note 2)	M14943
89	Seal, Mechanical Shaft	S32014
800A	Capscrew, 3/8 - 16 x 1" (8 Req.)	S26826
800B	Capscrew, 1/2 - 13 x 1" (4 Req.)	S26912
805	Washer, Lock	S23036
810	Plug, Pipe 1/4" NPT (4 Req.)	S23715
815	Ring, Retaining	S11207
•	Plug, Pipe 1/8" NPT (In Bracket)	S23714

• Not illustrated.

**Table I**

B/M No.	HP	PH	RPM	"U" Dim.	Imp. Dia.	Imp. No.
B74486	10	1	3600	7/8"	7.56"	L08076
B74487	10	3	3600	7/8"	7.56"	L08076
B74490	15	3	3600	7/8"	8.31"	L08077

**Table II**

HP	PH	Bracket No.	"AK" Fit	"U" Dim.	Motor Frame
10	1	L05331	8-1/2"	7/8"	215JM
10	3	L05331	8-1/2"	7/8"	213JM
15	3	L05331	8-1/2"	7/8"	215JM

**NOTE 1:** For an explanation of the tabulated material found on this page and for impeller key location, refer to *Supplement A* located at the beginning of this section.

**NOTE 2:** For seal flush line details, see *Supplement D*.

**NOTE 3:** Also accepts gasket S05126 as replacement for o-ring. See *Supplement E* located at the beginning of this section.



# Type "B" Single Stage Centrifugal Pump Electric Motor Drive

Section	CC
Page	80.12
Date	July 1, 2011
Supersedes 1/1/04	

## SILICON BRONZE IMPELLER B2ZPLS

### Flanged Case

### Mechanical Shaft Seal Construction

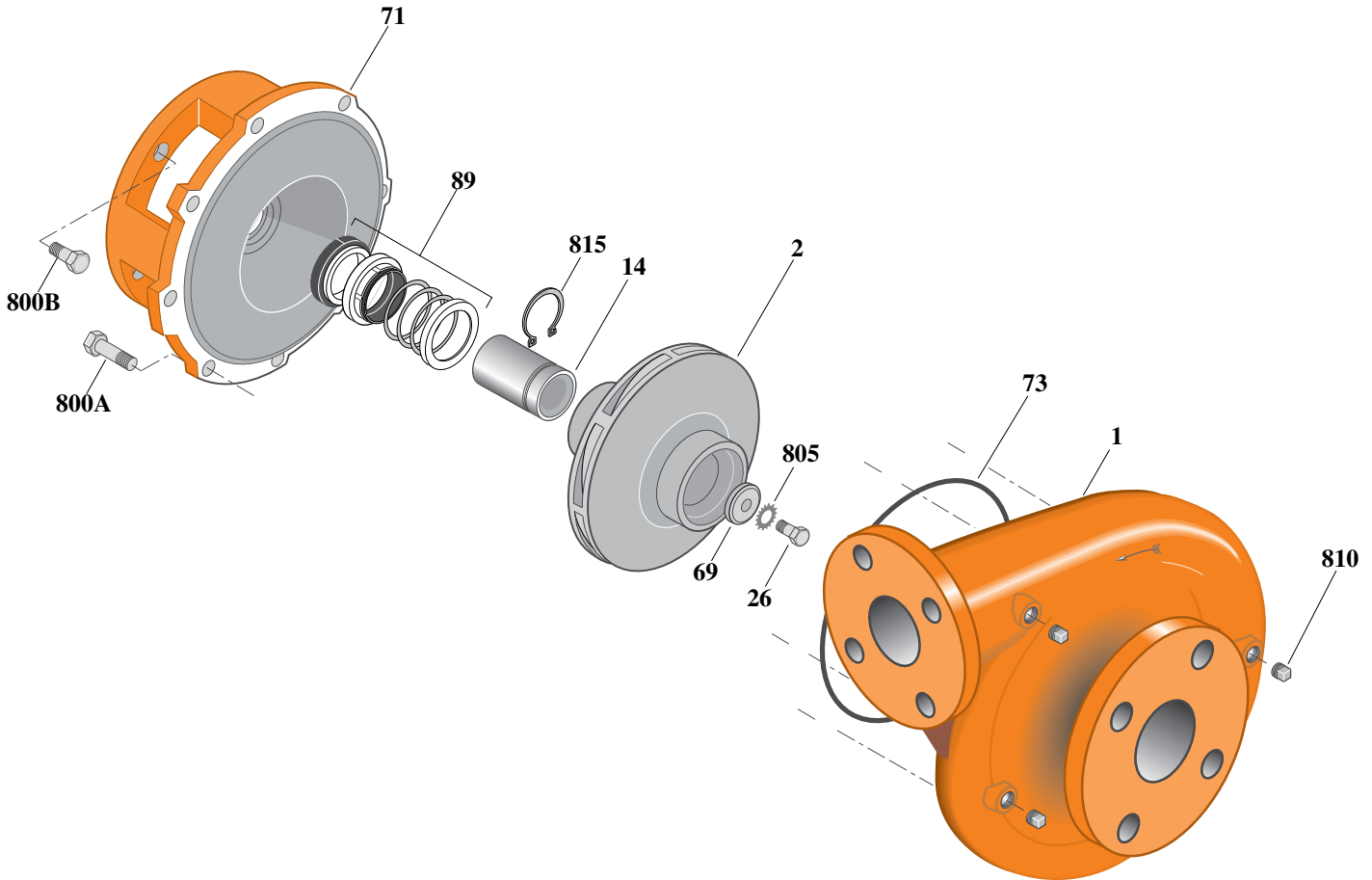

Item	Part Description	Part Number
1	Case, Volute	H05524
2	Impeller	See Table I
14	Sleeve, Shaft	S18869L
26	Screw, Impeller 1/2 - 13 x 1"	S23619
32	Key, 1/4 x 2-1/4" (See Note 1)	S23677
69	Washer, Impeller	S06319
71	Bracket	See Table II
73	O-Ring (See Note 2)	M14943
89	Seal, Mechanical Shaft	S32015
800A	Capscrew, 3/8 - 16 x 1" (8 Req.)	S26826
800B	Capscrew, 1/2 - 13 x 1" (4 Req.)	S26912
805	Washer, Lock	S23038
810	Plug, Pipe 1/4" NPT (4 Req.)	S23715
815	Ring, Retaining	S16767
•	Plug, Pipe 1/8" NPT (In Bracket)	S23714

• Not illustrated.

**Table I**

B/M No.	HP	PH	RPM	"U" Dim.	Imp. Dia.	Imp. No.
B74492	20	3	3600	1-1/4"	9.00"	L08075

**Table II**

HP	PH	Bracket No.	"AK" Fit	"U" Dim.	Motor Frame
20	3	L04615	8-1/2"	1-1/4"	254JM

**NOTE 1:** For an explanation of the tabulated material found on this page and for impeller key location, refer to *Supplement A* located at the beginning of this section.

**NOTE 2:** For seal flush line details, see *Supplement D*.

**NOTE 3:** Also accepts gasket S05126 as replacement for o-ring. See *Supplement E* located at the beginning of this section.