



# TYPE "B" SINGLE STAGE CENTRIFUGAL PUMP Electric Motor Drive

Section	CC
Page	100.1
Date	January 1, 2004
Supersedes 6/1/95	

## CAST IRON IMPELLER

## B2EPBL

### Threaded Case (NPT)

### Packing Construction

**TABLE I**

B/M No.	HP	PH	RPM	"U" Dim.	Imp. Dia.	Imp. No.
B53790	30	3	3600	1-1/4"	9.25"	M07696
B53791	40	3	3600	1-1/4"	9.94"	M05060

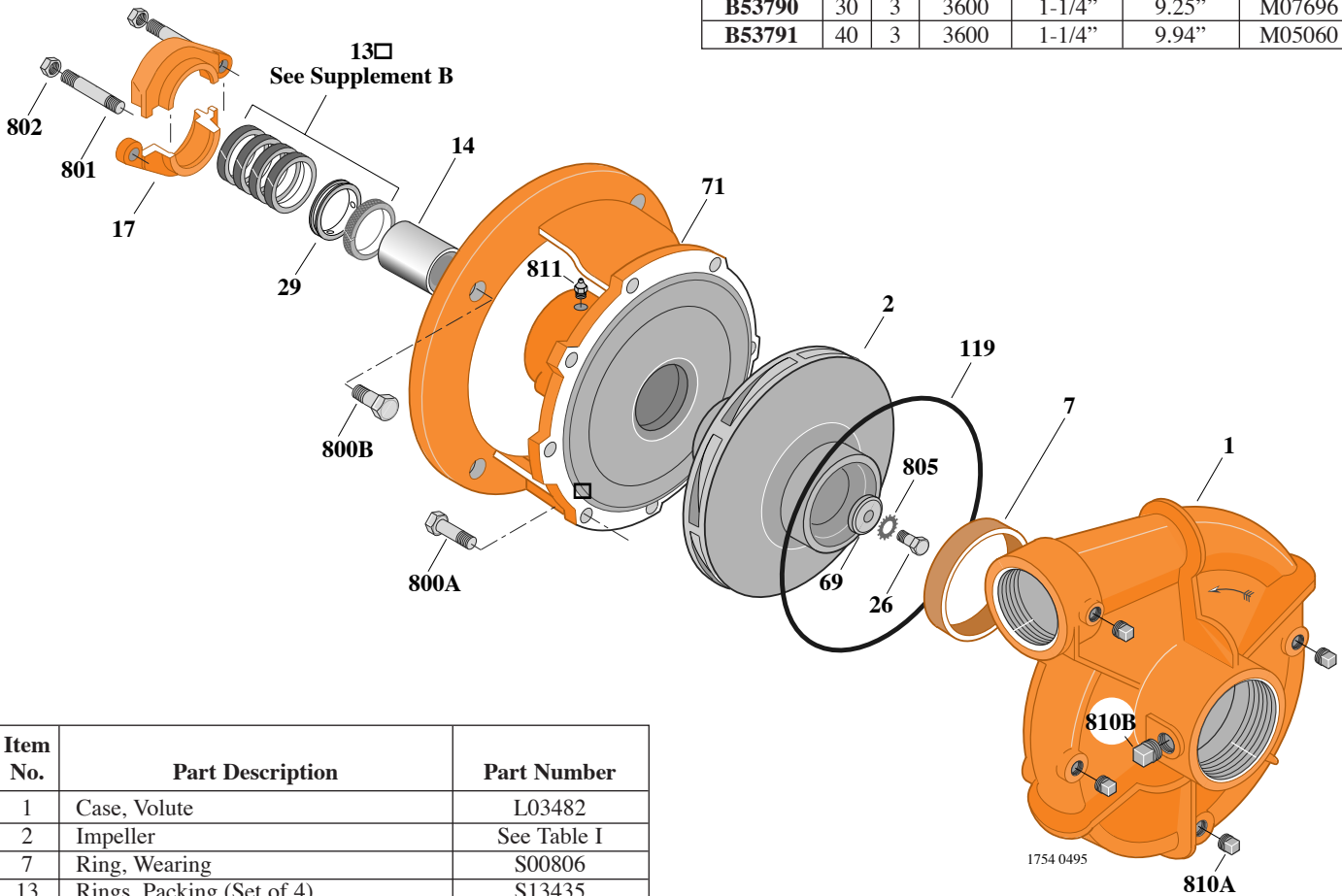

Item No.	Part Description	Part Number
1	Case, Volute	L03482
2	Impeller	See Table I
7	Ring, Wearing	S00806
13	Rings, Packing (Set of 4)	S13435
14	Sleeve, Shaft	S05149
17	Gland, Packing	B82470
26	Screw, Impeller 1/2 - 13 x 1-1/4"	S23621
29	Ring, Lantern	S19200
32	Key, 1/4 x 2-1/4" (See Note)	S23677
69	Washer, Impeller	S06319
71	Bracket	See Table II
119	O-Ring	S13760
800A	Capscrew, 1/2 - 13 x 1-1/4" (8 Req.)	S26914
800B	Capscrew, 5/8 - 11 x 1-1/2" (4 Req.)	S26999
801	Stud, 3/8 - 16 x 2-1/2" (2 Req.)	S04438
802	Nut, Hex 3/8 - 16 (2 Req.)	S23343
805	Washer, Lock	S23038
810A	Plug, Pipe 1/4 NPT (4 Req.)	S23715
810B	Plug, Pipe 1/2 NPT	S23717
811	Fitting, Grease	S23700

**TABLE II**

HP	PH	Bracket No.	"AK" Fit	"U" Dim.	Motor Frame
30	3	L03712	12-1/2"	1-1/4"	284JP
40	3	L03712	12-1/2"	1-1/4"	286JP

**NOTE:** For an explanation of the tabulated material found on this page and for impeller key location, refer to *Supplement A* located at the beginning of this section.



# TYPE "B" SINGLE STAGE CENTRIFUGAL PUMP Electric Motor Drive

Section	CC
Page	100.2
Date	January 1, 2004
Supersedes 6/1/95	

## CAST IRON IMPELLER

## B2EPBLS

### Threaded Case (NPT)

### Mechanical Shaft Seal Construction

TABLE I

B/M No.	HP	PH	RPM	"U" Dim.	Imp. Dia.	Imp. No.
B54084	30	3	3600	1-1/4"	9.25"	M07696
B54085	40	3	3600	1-1/4"	9.94"	M05060

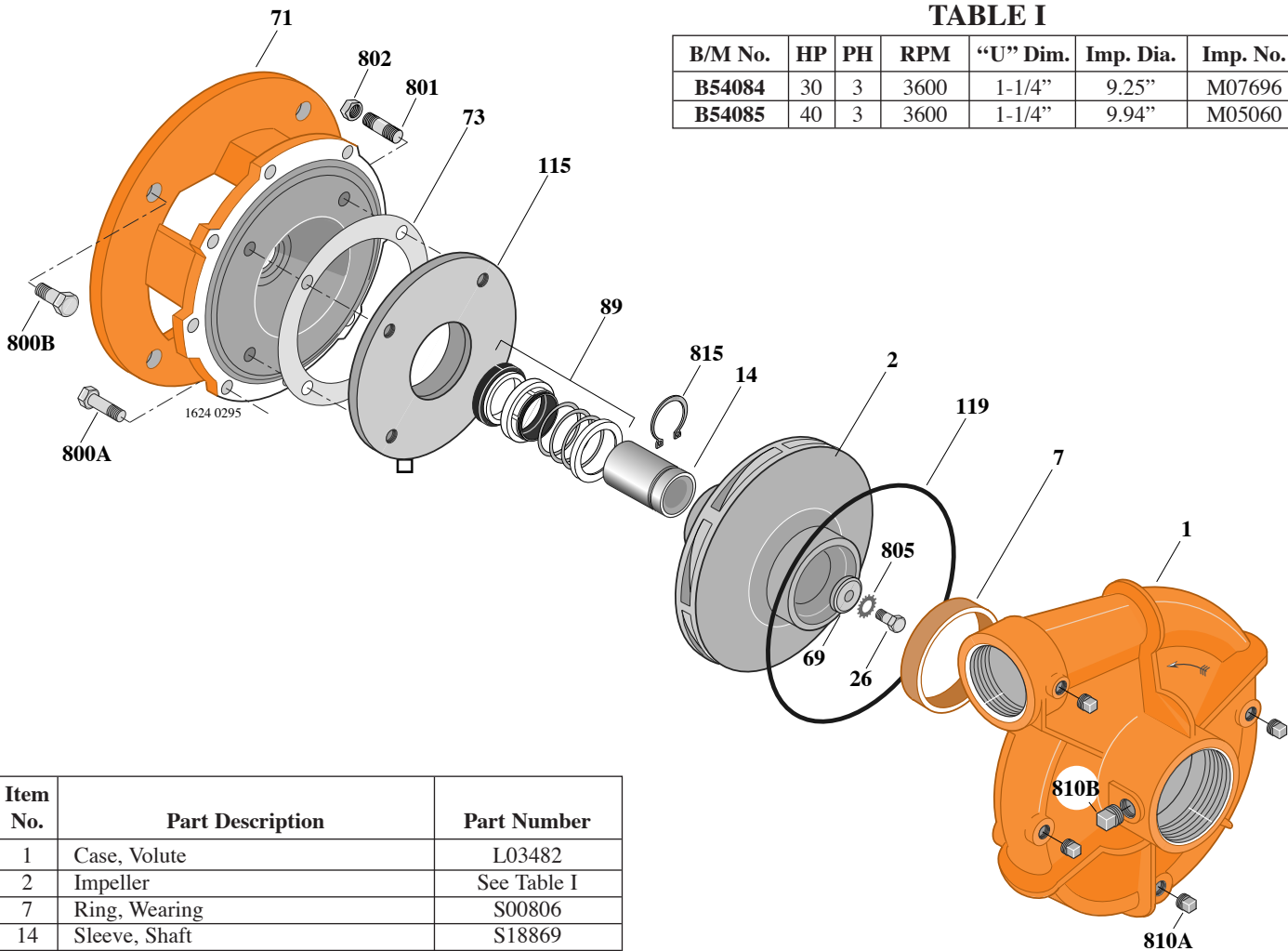

Item No.	Part Description	Part Number
1	Case, Volute	L03482
2	Impeller	See Table I
7	Ring, Wearing	S00806
14	Sleeve, Shaft	S18869
26	Screw, Impeller 1/2 - 13 x 1-1/4"	S23621
32	Key, 1/4 x 2-1/4" (See Note)	S23677
69	Washer, Impeller	S06319
71	Bracket	See Table II
73	Gasket, Balance Ring	S09943
89	Seal, Mechanical Shaft	S32015
115	Ring, Balance	S19262
119	O-Ring	S13760
800A	Capscrew, 1/2 - 13 x 1-1/4" (8 Req.)	S26914
800B	Capscrew, 5/8 - 11 x 1-1/2" (4 Req.)	S26999
801	Stud, 3/8 - 16 x 1-1/4" (4 Req.)	S23994
802	Nut, 3/8 - 16 (4 Req.)	S23103
805	Washer, Lock	S23038
810A	Plug, Pipe 1/4 NPT (4 Req.)	S23715
810B	Plug, Pipe 1/2 NPT	S23717
815	Ring, Retaining	S16767

TABLE II

HP	PH	Bracket No.	"AK" Fit	"U" Dim.	Motor Frame
30	3	L04628	12-1/2"	1-1/4"	284JM
40	3	L04628	12-1/2"	1-1/4"	286JM

**NOTE:** For an explanation of the tabulated material found on this page and for impeller key location, refer to *Supplement A* located at the beginning of this section.



# TYPE "B" SINGLE STAGE CENTRIFUGAL PUMP Electric Motor Drive

Section	CC
Page	100.3
Date	September 1, 1995
Supersedes/New	

## SILICON BRONZE IMPELLER

## B2EPBL

Threaded Case (NPT)

Packing Construction

**TABLE I**

B/M No.	HP	PH	RPM	"U" Dim.	Imp. Dia.	Imp. No.
B74329	30	3	3600	1-1/4"	9.25"	M10990
B74333	40	3	3600	1-1/4"	9.94"	M10989

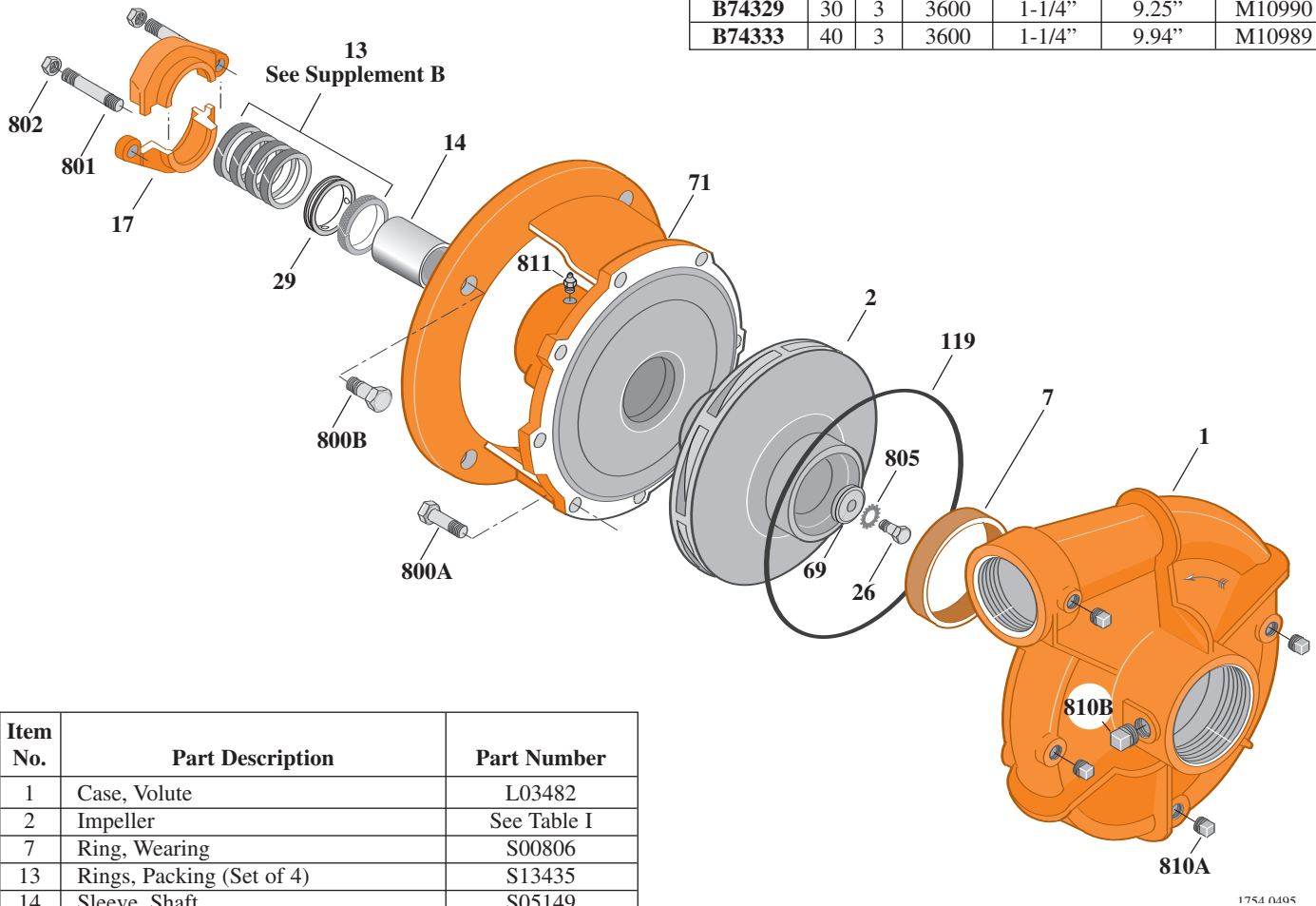

Item No.	Part Description	Part Number
1	Case, Volute	L03482
2	Impeller	See Table I
7	Ring, Wearing	S00806
13	Rings, Packing (Set of 4)	S13435
14	Sleeve, Shaft	S05149
17	Gland, Packing	S12034
26	Screw, Impeller 1/2 - 13 x 1-1/4"	S23621
29	Ring, Lantern	S19200
32	Key, 1/4 x 2-1/4" (See Note)	S23677
69	Washer, Impeller	S06319
71	Bracket	See Table II
119	O-Ring	S13760
800A	Capscrew, 1/2 - 13 x 1-1/4" (8 Req.)	S26914
800B	Capscrew, 5/8 - 11 x 1-1/2" (4 Req.)	S26999
801	Stud, 3/8 - 16 x 2-1/2" (2 Req.)	S04438
802	Nut, Hex 3/8 - 16 (2 Req.)	S23343
805	Washer, Lock	S23038
810A	Plug, Pipe 1/4 NPT (4 Req.)	S23715
810B	Plug, Pipe 1/2 NPT	S23717
811	Fitting, Grease	S23700

**TABLE II**

HP	PH	Bracket No.	"AK" Fit	"U" Dim.	Motor Frame
30	3	L03712	12-1/2"	1-1/4"	284JP
40	3	L03712	12-1/2"	1-1/4"	286JP

**NOTE:** For an explanation of the tabulated material found on this page and for impeller key location, refer to *Supplement A* located at the beginning of this section.



# TYPE "B" SINGLE STAGE CENTRIFUGAL PUMP Electric Motor Drive

Section	CC
Page	100.4
Date	September 1, 1995
Supersedes/New	

## SILICON BRONZE IMPELLER

## B2EPBLS

### Threaded Case (NPT)

### Mechanical Shaft Seal Construction

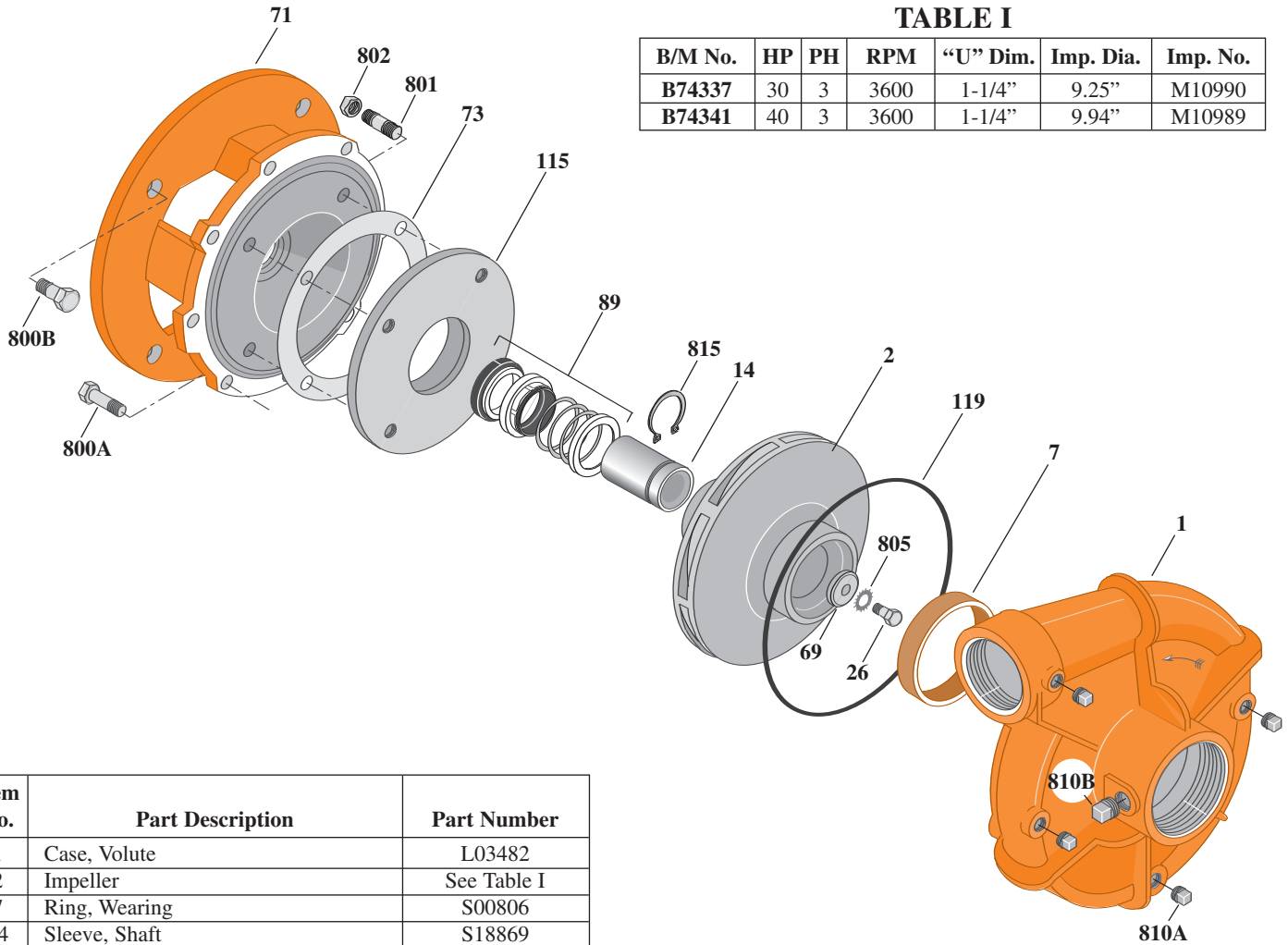

TABLE I

B/M No.	HP	PH	RPM	"U" Dim.	Imp. Dia.	Imp. No.
B74337	30	3	3600	1-1/4"	9.25"	M10990
B74341	40	3	3600	1-1/4"	9.94"	M10989

Item No.	Part Description	Part Number
1	Case, Volute	L03482
2	Impeller	See Table I
7	Ring, Wearing	S00806
14	Sleeve, Shaft	S18869
26	Screw, Impeller 1/2 - 13 x 1-1/4"	S23621
32	Key, 1/4 x 2-1/4" (See Note)	S23677
69	Washer, Impeller	S06319
71	Bracket	See Table II
73	Gasket, Balance Ring	S09943
89	Seal, Mechanical Shaft	S32015
115	Ring, Balance	S19262
119	O-Ring	S13760
800A	Capscrew, 1/2 - 13 x 1-1/4" (8 Req.)	S26914
800B	Capscrew, 5/8 - 11 x 1-1/2" (4 Req.)	S26999
801	Stud, 3/8 - 16 x 1-1/4" (4 Req.)	S23994
802	Nut, 3/8 - 16 (4 Req.)	S23103
805	Washer, Lock	S23038
810A	Plug, Pipe 1/4 NPT (4 Req.)	S23715
810B	Plug, Pipe 1/2 NPT	S23717
815	Ring, Retaining	S16767

TABLE II

HP	PH	Bracket No.	"AK" Fit	"U" Dim.	Motor Frame
30	3	L04628	12-1/2"	1-1/4"	284JM
40	3	L04628	12-1/2"	1-1/4"	286JM

**NOTE:** For an explanation of the tabulated material found on this page and for impeller key location, refer to *Supplement A* located at the beginning of this section.



# TYPE "B" SINGLE STAGE CENTRIFUGAL PUMP Electric Motor Drive

Section	CC
Page	100.5
Date	January 1, 2004
Supersedes 9/1/97	

## SILICON BRONZE IMPELLER

## B2EPBL

### Threaded Case (NPT)

### Packing Construction

**TABLE I**

B/M No.	HP	PH	RPM	"U" Dim.	Imp. Dia.	Imp. No.
B74329	30	3	3600	1-1/4"	9.25"	M10990
B74333	40	3	3600	1-1/4"	9.94"	M10989

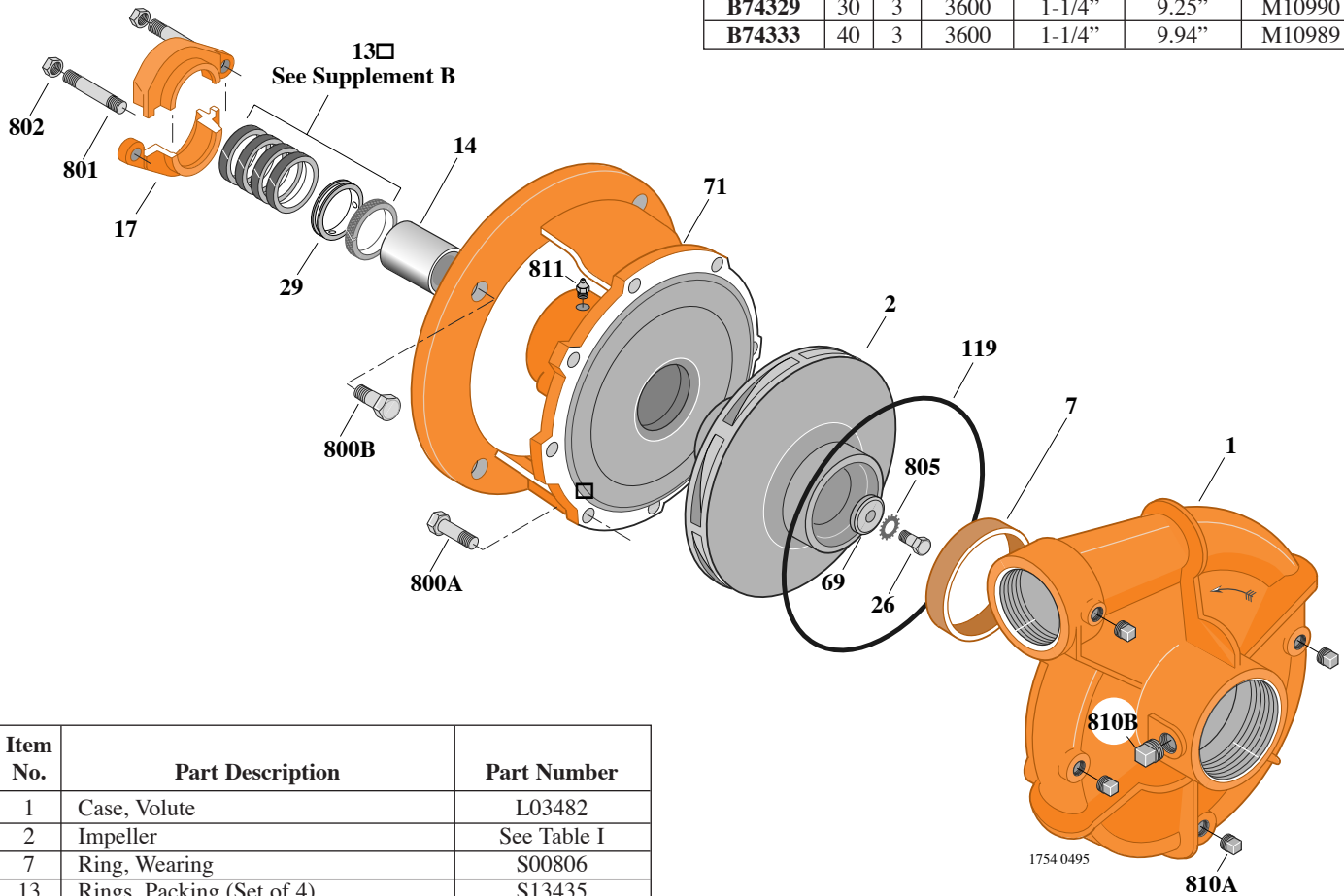

Item No.	Part Description	Part Number
1	Case, Volute	L03482
2	Impeller	See Table I
7	Ring, Wearing	S00806
13	Rings, Packing (Set of 4)	S13435
14	Sleeve, Shaft	S05149
17	Gland, Packing	B82470
26	Screw, Impeller 1/2 - 13 x 1-1/4"	S23621
29	Ring, Lantern	S19200
32	Key, 1/4 x 2-1/4" (See Note)	S23677
69	Washer, Impeller	S06319
71	Bracket	See Table II
119	O-Ring	S13760
800A	Capscrew, 1/2 - 13 x 1-1/4" (8 Req.)	S26914
800B	Capscrew, 5/8 - 11 x 1-1/2" (4 Req.)	S26999
801	Stud, 3/8 - 16 x 2-1/2" (2 Req.)	S04438
802	Nut, Hex 3/8 - 16 (2 Req.)	S23343
805	Washer, Lock	S23038
810A	Plug, Pipe 1/4" NPT (4 Req.)	S23715
810B	Plug, Pipe 1/2" NPT	S23717
811	Fitting, Grease	S23700

**TABLE II**

HP	PH	Bracket No.	"AK" Fit	"U" Dim.	Motor Frame
30	3	L03712	12-1/2"	1-1/4"	284JP
40	3	L03712	12-1/2"	1-1/4"	286JP

**NOTE:** For an explanation of the tabulated material found on this page and for impeller key location, refer to *Supplement A* located at the beginning of this section.



# TYPE "B" SINGLE STAGE CENTRIFUGAL PUMP Electric Motor Drive

Section	CC
Page	100.6
Date	January 1, 2004
Supersedes 9/1/97	

## SILICON BRONZE IMPELLER

## B2EPBLS

### Threaded Case (NPT)

### Mechanical Shaft Seal Construction

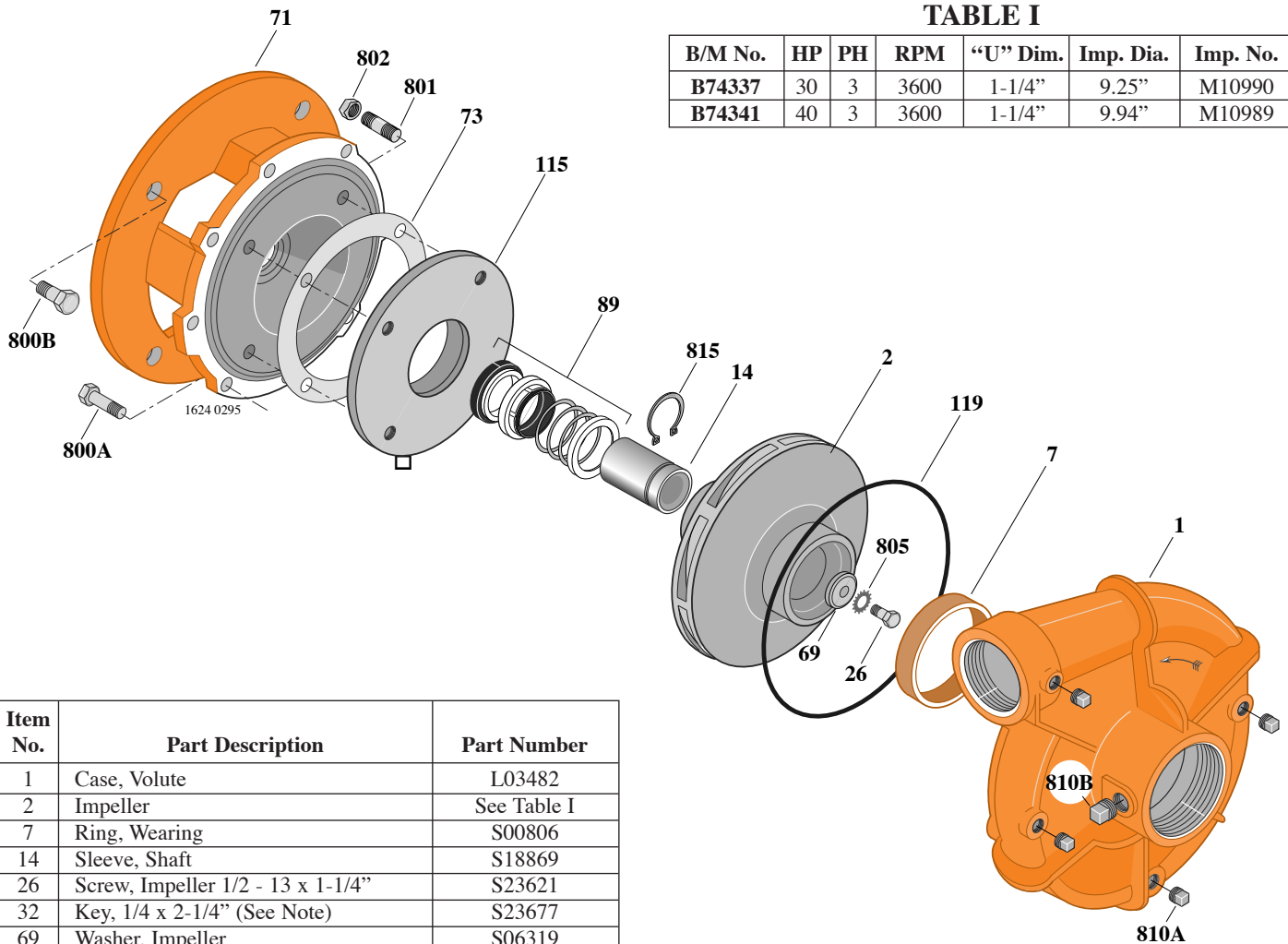

TABLE I

B/M No.	HP	PH	RPM	"U" Dim.	Imp. Dia.	Imp. No.
B74337	30	3	3600	1-1/4"	9.25"	M10990
B74341	40	3	3600	1-1/4"	9.94"	M10989

Item No.	Part Description	Part Number
1	Case, Volute	L03482
2	Impeller	See Table I
7	Ring, Wearing	S00806
14	Sleeve, Shaft	S18869
26	Screw, Impeller 1/2 - 13 x 1-1/4"	S23621
32	Key, 1/4 x 2-1/4" (See Note)	S23677
69	Washer, Impeller	S06319
71	Bracket	See Table II
73	Gasket, Balance Ring	S09943
89	Seal, Mechanical Shaft	S32015
115	Ring, Balance	S19262
119	O-Ring	S13760
800A	Capscrew, 1/2 - 13 x 1-1/4" (8 Req.)	S26914
800B	Capscrew, 5/8 - 11 x 1-1/2" (4 Req.)	S26999
801	Stud, 3/8 - 16 x 1-1/4" (4 Req.)	S23994
802	Nut, 3/8 - 16 (4 Req.)	S23103
805	Washer, Lock	S23038
810A	Plug, Pipe 1/4" NPT (4 Req.)	S23715
810B	Plug, Pipe 1/2" NPT	S23717
815	Ring, Retaining	S16767
•	Plug, Pipe 1/8" NPT (In Bracket)	S23714

• Not illustrated.

TABLE II

HP	PH	Bracket No.	"AK" Fit	"U" Dim.	Motor Frame
30	3	L04628	12-1/2"	1-1/4"	284JM
40	3	L04628	12-1/2"	1-1/4"	286JM

**NOTE:** For an explanation of the tabulated material found on this page and for impeller key location, refer to *Supplement A* located at the beginning of this section.

**NOTE:** For seal flush line details, see *Supplement D*.





# TYPE "B" SINGLE STAGE CENTRIFUGAL PUMP Electric Motor Drive

Section	CC
Page	100.7
Date	January 1, 2004
Supersedes 9/1/97	

## SILICON BRONZE IMPELLER

## B2EPBL

### Flanged Case

### Packing Construction

**TABLE I**

B/M No.	HP	PH	RPM	"U" Dim.	Imp. Dia.	Imp. No.
<b>B74496</b>	30	3	3600	1-1/4"	9.25"	M10990
<b>B74499</b>	40	3	3600	1-1/4"	9.94"	M10989

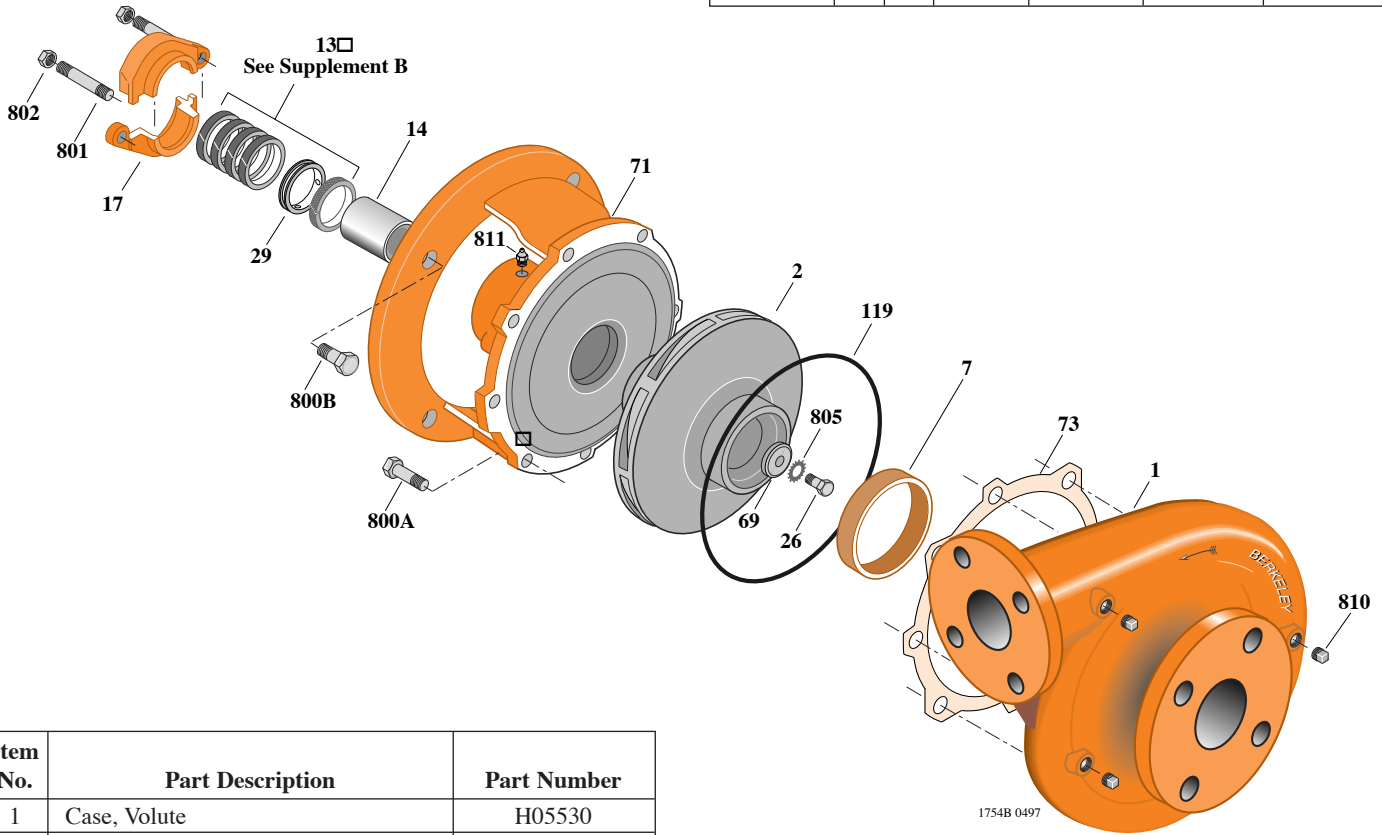

Item No.	Part Description	Part Number
1	Case, Volute	H05530
2	Impeller	See Table I
7	Ring, Wearing	S00806
13	Rings, Packing (Set of 4)	S13435
14	Sleeve, Shaft	S05149
17	Gland, Packing	B82470
26	Screw, Impeller 1/2 - 13 x 1-1/4"	S23621
29	Ring, Lantern	S19200
32	Key, 1/4 x 2-1/4" (See Note)	S23677
69	Washer, Impeller	S06319
71	Bracket	See Table II
119	O-Ring	S13760
800A	Capscrew, 1/2 - 13 x 1-1/4" (8 Req.)	S26914
800B	Capscrew, 5/8 - 11 x 1-1/2" (4 Req.)	S26999
801	Stud, 3/8 - 16 x 2-1/2" (2 Req.)	S04438
802	Nut, Hex 3/8 - 16 (2 Req.)	S23343
805	Washer, Lock	S23038
810	Plug, Pipe 1/4" NPT (4 Req.)	S23715
811	Fitting, Grease	S23700

1754B 0497

**TABLE II**

HP	PH	Bracket No.	"AK" Fit	"U" Dim.	Motor Frame
30	3	L03712	12-1/2"	1-1/4"	284JP
40	3	L03712	12-1/2"	1-1/4"	286JP

**NOTE:** For an explanation of the tabulated material found on this page and for impeller key location, refer to *Supplement A* located at the beginning of this section.



# TYPE "B" SINGLE STAGE CENTRIFUGAL PUMP Electric Motor Drive

Section	CC
Page	100.8
Date	January 1, 2004
Supersedes 9/1/97	

## SILICON BRONZE IMPELLER

## B2EPBLS

### Flanged Case

### Mechanical Shaft Seal Construction

TABLE I

B/M No.	HP	PH	RPM	"U" Dim.	Imp. Dia.	Imp. No.
B74502	30	3	3600	1-1/4"	9.25"	M10990
B74505	40	3	3600	1-1/4"	9.94"	M10989

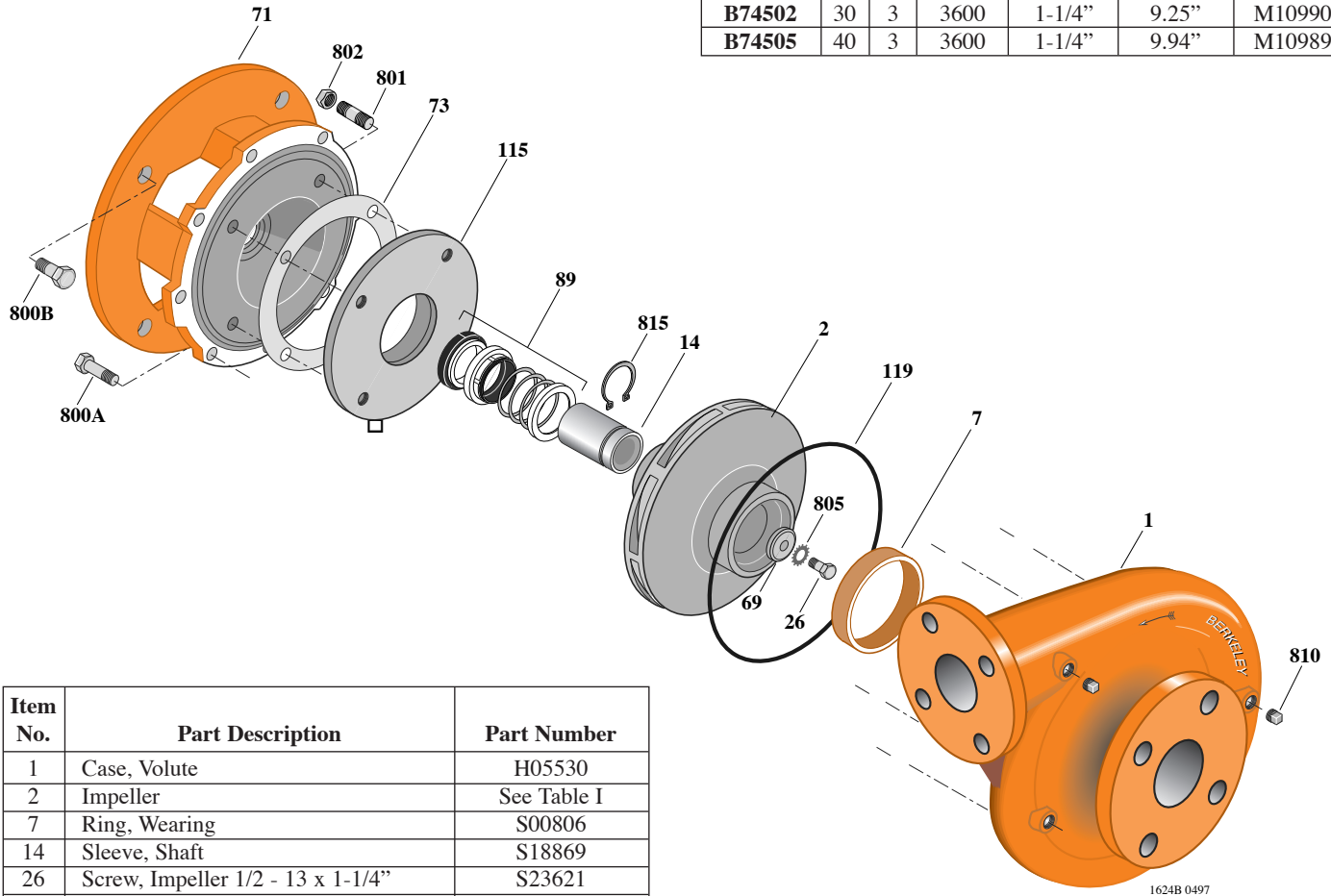

Item No.	Part Description	Part Number
1	Case, Volute	H05530
2	Impeller	See Table I
7	Ring, Wearing	S00806
14	Sleeve, Shaft	S18869
26	Screw, Impeller 1/2 - 13 x 1-1/4"	S23621
32	Key, 1/4 x 2-1/4" (See Note)	S23677
69	Washer, Impeller	S06319
71	Bracket	See Table II
73	Gasket, Balance Ring	S09943
89	Seal, Mechanical Shaft	S32015
115	Ring, Balance	S19262
119	O-Ring	S13760
800A	Capscrew, 1/2 - 13 x 1-1/4" (8 Req.)	S26914
800B	Capscrew, 5/8 - 11 x 1-1/2" (4 Req.)	S26999
801	Stud, 3/8 - 16 x 1-1/4" (4 Req.)	S23994
802	Nut, 3/8 - 16 (4 Req.)	S23103
805	Washer, Lock	S23038
810	Plug, Pipe 1/4" NPT (4 Req.)	S23715
815	Ring, Retaining	S16767
•	Plug, Pipe 1/8" NPT (In Bracket)	S23714

• Not illustrated.

TABLE II

HP	PH	Bracket No.	"AK" Fit	"U" Dim.	Motor Frame
30	3	L04628	12-1/2"	1-1/4"	284JM
40	3	L04628	12-1/2"	1-1/4"	286JM

**NOTE:** For an explanation of the tabulated material found on this page and for impeller key location, refer to *Supplement A* located at the beginning of this section.

**NOTE:** For seal flush line details, see *Supplement D*.





# TYPE "B" SINGLE STAGE CENTRIFUGAL PUMP Electric Motor Drive

Section	CC
Page	100.9
Date	January 1, 2004
Supersedes/NEW	

## CAST IRON IMPELLER

## B2EPBLS

### Flanged Case

### Mechanical Shaft Seal Construction

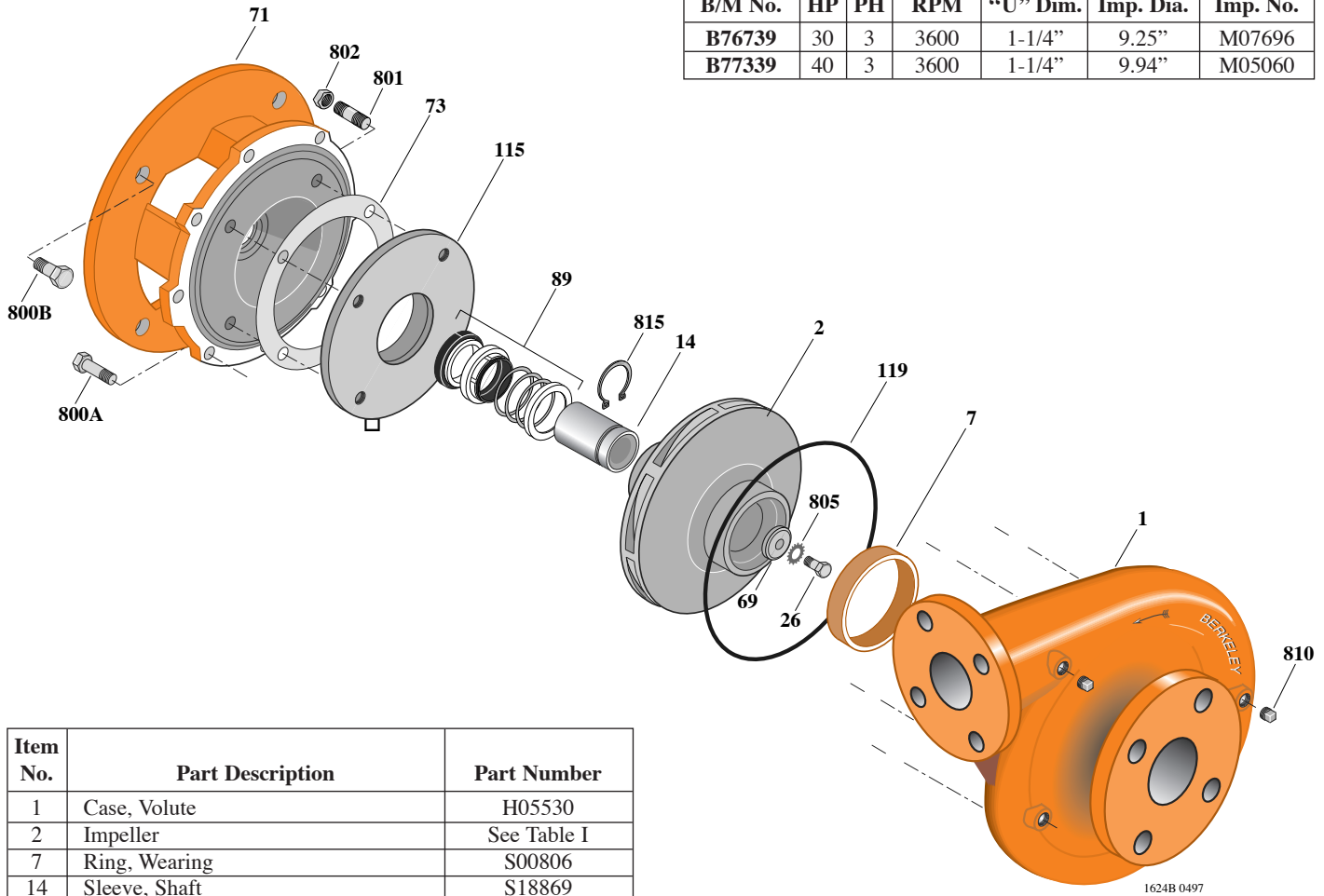

**TABLE I**

B/M No.	HP	PH	RPM	"U" Dim.	Imp. Dia.	Imp. No.
B76739	30	3	3600	1-1/4"	9.25"	M07696
B77339	40	3	3600	1-1/4"	9.94"	M05060

Item No.	Part Description	Part Number
1	Case, Volute	H05530
2	Impeller	See Table I
7	Ring, Wearing	S00806
14	Sleeve, Shaft	S18869
26	Screw, Impeller 1/2 - 13 x 1-1/4"	S23621
32	Key, 1/4 x 2-1/4" (See Note)	S23677
69	Washer, Impeller	S06319
71	Bracket	See Table II
73	Gasket, Balance Ring	S09943
89	Seal, Mechanical Shaft	S32015
115	Ring, Balance	S19262
119	O-Ring	S13760
800A	Capscrew, 1/2 - 13 x 1-1/4" (8 Req.)	S26914
800B	Capscrew, 5/8 - 11 x 1-1/2" (4 Req.)	S26999
801	Stud, 3/8 - 16 x 1-1/4" (4 Req.)	S23994
802	Nut, 3/8 - 16 (4 Req.)	S23103
805	Washer, Lock	S23038
810A	Plug, Pipe 1/4 NPT (4 Req.)	S23715
810B	Plug, Pipe 1/2 NPT	S23717
815	Ring, Retaining	S16767

**TABLE II**

HP	PH	Bracket No.	"AK" Fit	"U" Dim.	Motor Frame
30	3	L04628	12-1/2"	1-1/4"	284JM
40	3	L04628	12-1/2"	1-1/4"	286JM

**NOTE:** For an explanation of the tabulated material found on this page and for impeller key location, refer to *Supplement A* located at the beginning of this section.