



Type "B" Single Stage Centrifugal Pump Electric Motor Drive

Section	CC
Page	40.1
Date	July 1, 2011
Supersedes 1/1/04	

CAST IRON IMPELLERB1-1/2ZPL

Threaded Case (NPT)

Packing Construction

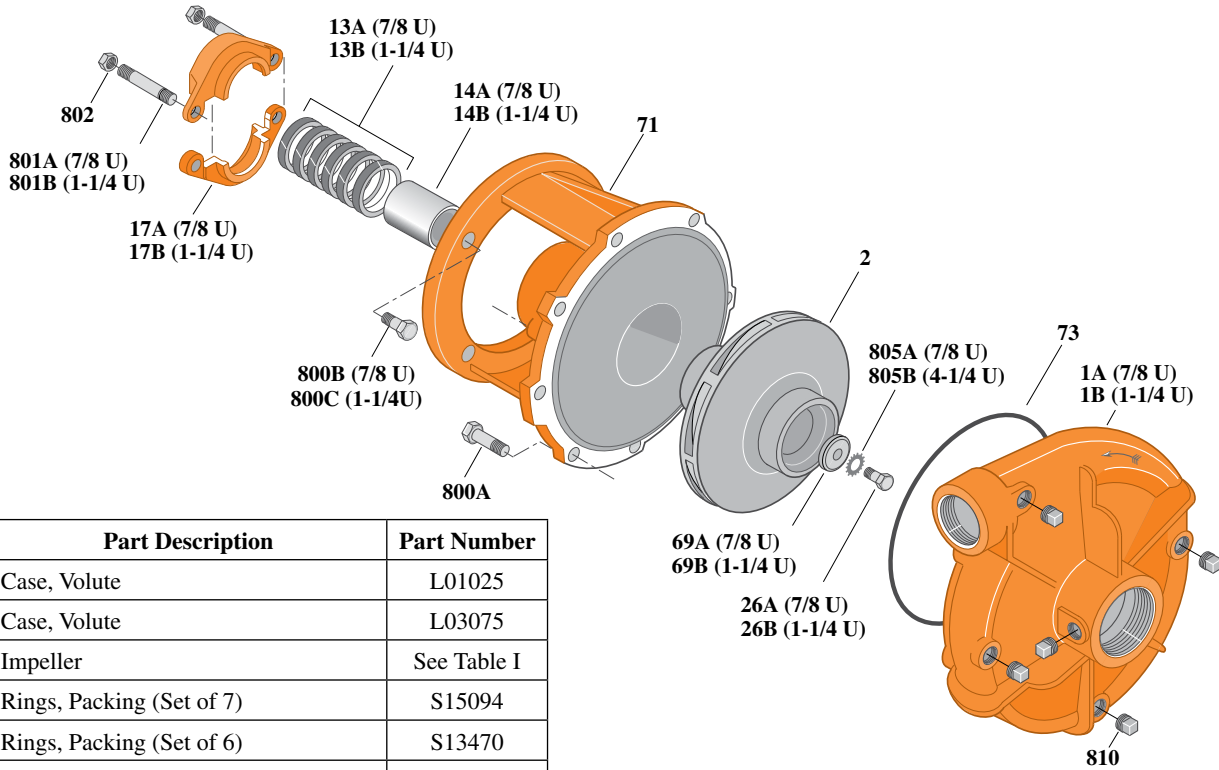

Item	Part Description	Part Number
1A	Case, Volute	L01025
1B	Case, Volute	L03075
2	Impeller	See Table I
13A	Rings, Packing (Set of 7)	S15094
13B	Rings, Packing (Set of 6)	S13470
14A	Sleeve, Shaft (2 Req.)	S00619L
14B	Sleeve, Shaft	S05149L
17A	Gland, Packing	B82469
17B	Gland, Packing	B82470
26A	Screw, Impeller 3/8 - 16 x 1"	S23566
26B	Screw, Impeller 1/2 - 13 x 1"	S23619
32A	Key, 3/16 x 1-1/4" (See Note 1)	S34383
32B	Key, 1/4 x 2/14" (See Note 1)	S23677
69A	Washer, Impeller	S06314
69B	Washer, Impeller	S06317
71	Bracket	See Table II
73	O-Ring (See Note 2)	M14943
800A	Capscrew, 3/8 - 16 x 1" (12 Req.)	S26826
800B	Capscrew, 3/8 - 16 x 1-1/8" (8 Req.)	S26827
800C	Capscrew, 1/2 - 13 x 1-1/2" (4 Req.)	S26916
801A	Stud, 3/8 - 16 x 3" (2 Req.)	S04439
801B	Stud, 3/8 - 16 x 4" (2 Req.)	S08303
802	Nut, Hex 3/8 - 16 (2 Req.)	S23343
805A	Washer, Lock	S23036
805B	Washer, Lock	S23038
810	Plug, Pipe 1/4 NPT (5 Req.)	S23715

Table I

B/M No.	HP	PH	RPM	"U" Dim.	Imp. Dia.	Imp. No.
B53750	7.5	1	3600	1-1/4"	7.18"	M07692
B53751	7.5	3	3600	7/8"	7.18"	M07693
B55574	10	1	3600	1-1/4"	7.88"	M07691
B53752	10	3	3600	1-1/4"	7.88"	M07691
B53753	15	3	3600	1-1/4"	8.75"	M07690

Table II

HP	PH	Bracket No.	"AK" Fit	"U" Dim.	Motor Frame
7.5	1	L03827	8-1/2"	1-1/4"	213JP
7.5	3	H00950	4-1/2"	7/8"	184JP
10	1	L03827	8-1/2"	1-1/4"	215JP
10	3	L03827	8-1/2"	1-1/4"	213JP
15	3	L03827	8-1/2"	1-1/4"	215JP

NOTE 1: For an explanation of the tabulated material found on this page and for impeller key location, refer to *Supplement A* located at the beginning of this section.

NOTE 2: Also accepts gasket S05126 as replacement for o-ring. See *Supplement E* located at the beginning of this section.



Type "B" Single Stage Centrifugal Pump Electric Motor Drive

Section	CC
Page	40.2
Date	July 1, 2011
Supersedes 1/1/04	

CAST IRON IMPELLER B1-1/2ZPLS

Threaded Case (NPT)

Mechanical Shaft Seal Construction

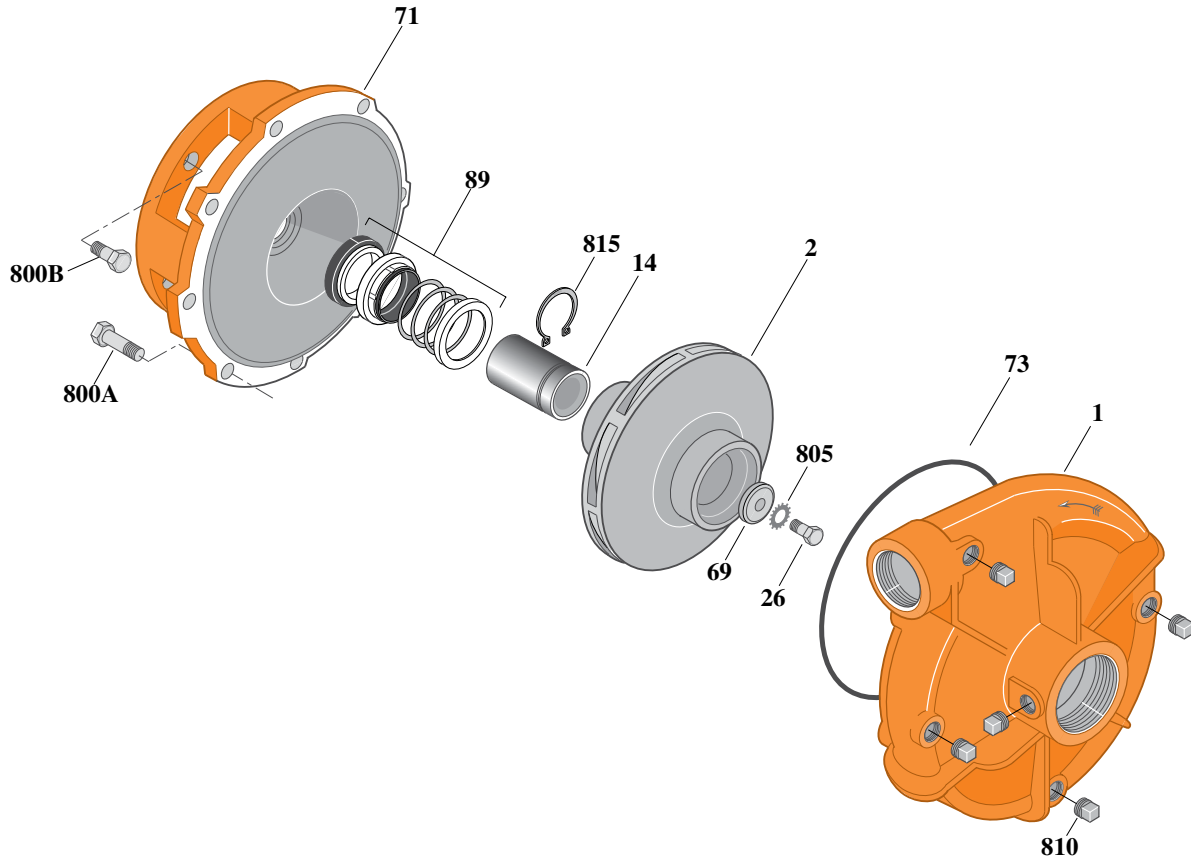

Table I

B/M No.	HP	PH	RPM	"U" Dim.	Imp. Dia.	Imp. No.
B54499	7.5	1	3600	7/8"	7.18"	M07693
B54500	7.5	3	3600	7/8"	7.18"	M07693
B54646	10	1	3600	7/8"	7.88"	M07758
B54502	10	3	3600	7/8"	7.88"	M07758
B54504	15	3	3600	7/8"	8.75"	M07759

Table II

HP	PH	Bracket No.	"AK" Fit	"U" Dim.	Motor Frame
7.5	1	L05331	8-1/2"	7/8"	213JM
7.5	3	L05332	4-1/2"	7/8"	184JM
10	1	L05331	8-1/2"	7/8"	215JM
10	3	L05331	8-1/2"	7/8"	213JM
15	3	L05331	8-1/2"	7/8"	215JM

Item	Part Description	Part Number
1	Case, Volute	L01025
2	Impeller	See Table I
14	Sleeve, Shaft	S19310L
26	Screw, Impeller 3/8 - 16 x 1"	S23566
32	Key, 3/16 x 1-1/4" (See Note 1)	S34383
69	Washer, Impeller	S06314
71	Bracket	See Table II
73	O-Ring (See Note 2)	M14943
89	Seal, Mechanical Shaft	S32014
800A	Capscrew, 3/8 - 16 x 1" (8 Req.)	S26826
800B	Capscrew, 1/2 - 13 x 1" (4 Req.)	S26912
805	Washer, Lock	S23036
810	Plug, Pipe 1/4 NPT (5 Req.)	S23715
815	Ring, Retaining	S11207

NOTE 1: For an explanation of the tabulated material found on this page and for impeller key location, refer to **Supplement A** located at the beginning of this section.

NOTE 2: Also accepts gasket S05126 as replacement for o-ring. See **Supplement E** located at the beginning of this section.



Type "B" Single Stage Centrifugal Pump Electric Motor Drive

Section	CC
Page	40.3
Date	July 1, 2011
Supersedes 1/1/04	

CAST IRON IMPELLER

B1-1/2ZPLS

Threaded Case (NPT)

Mechanical Shaft Seal Construction

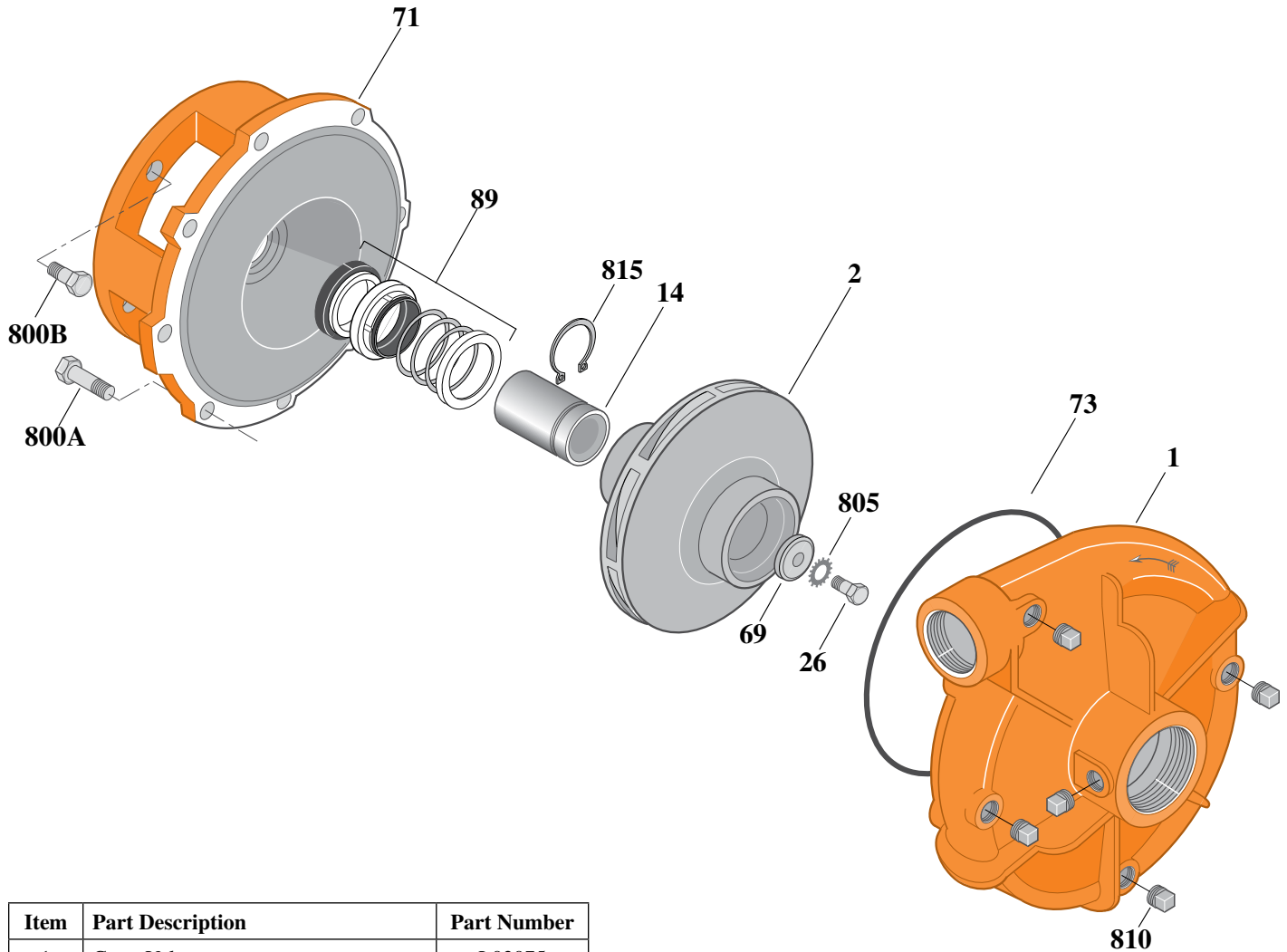

Item	Part Description	Part Number
1	Case, Volute	L03075
2	Impeller	See Table I
14	Sleeve, Shaft	S18869L
26	Screw, Impeller 1/2 - 13 x 1"	S23619
32	Key, 1/4 x 2-1/4" (See Note 1)	S23677
69	Washer, Impeller	S06319
71	Bracket	See Table II
73	O-Ring (See Note 2)	M14943
89	Seal, Mechanical Shaft	S32015
800A	Capscrew, 3/8 - 16 x 1-1/8" (8 Req.)	S26827
800B	Capscrew, 1/2 - 13 x 1" (4 Req.)	S26912
805	Washer, Lock	S23038
810	Plug, Pipe 1/4 NPT (5 Req.)	S23715
815	Ring, Retaining	S16767

Table I

B/M No.	HP	PH	RPM	"U" Dim.	Imp. Dia.	Imp. No.
B08607	20	3	3600	1-1/4"	9.00"	M02928

Table II

HP	PH	Bracket No.	"AK" Fit	"U" Dim.	Motor Frame
20	3	L04615	8-1/2"	1-1/4"	254JM

NOTE 1: For an explanation of the tabulated material found on this page and for impeller key location, refer to *Supplement A* located at the beginning of this section.

NOTE 2: Also accepts gasket S05126 as replacement for o-ring. See *Supplement E* located at the beginning of this section.



Type "B" Single Stage Centrifugal Pump Electric Motor Drive

Section	CC
Page	40.4
Date	July 1, 2011
Supersedes 1/1/04	

BRONZE IMPELLERB1-1/2ZPL

Threaded Case (NPT)

Packing Construction

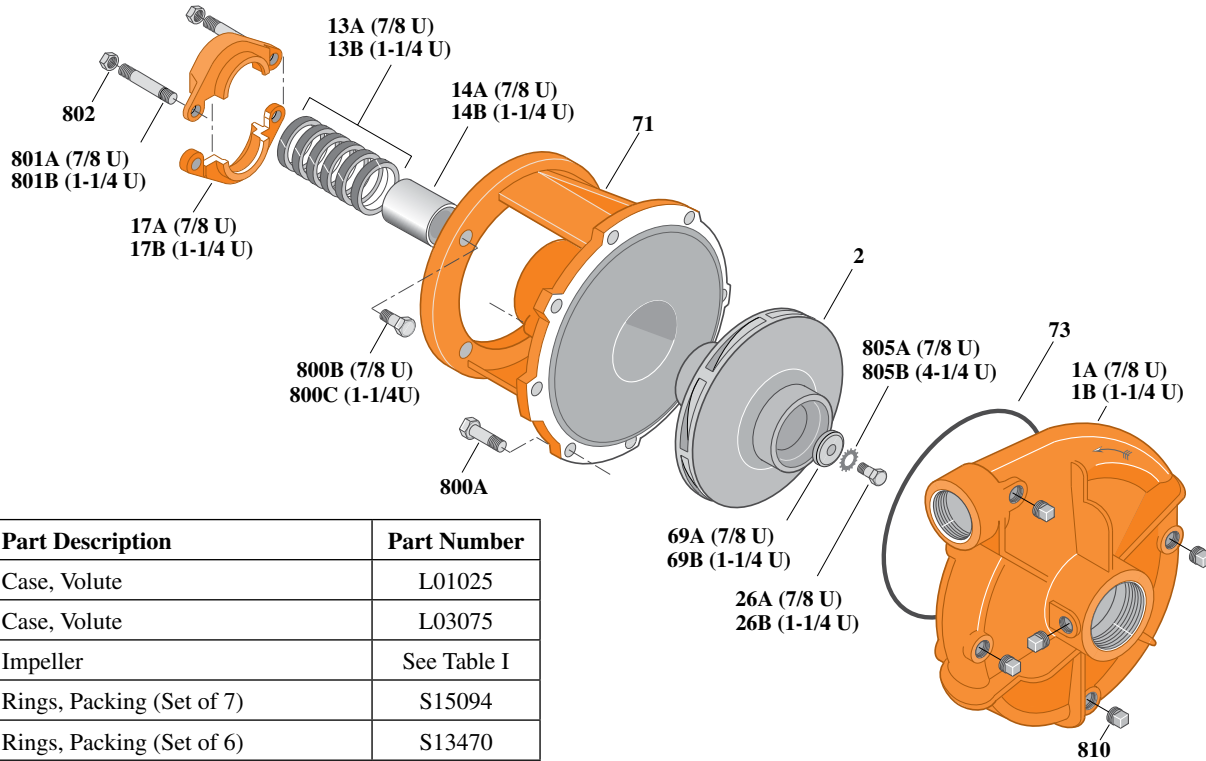

Item	Part Description	Part Number
1A	Case, Volute	L01025
1B	Case, Volute	L03075
2	Impeller	See Table I
13A	Rings, Packing (Set of 7)	S15094
13B	Rings, Packing (Set of 6)	S13470
14A	Sleeve, Shaft (2 Req.)	S00619L
14B	Sleeve, Shaft	S05149L
17A	Gland, Packing	B82469
17B	Gland, Packing	B82470
26A	Screw, Impeller 3/8 - 16 x 1"	S23566
26B	Screw, Impeller 1/2 - 13 x 1"	S23619
32A	Key, 3/16 x 1-1/4" (See Note 1)	S34383
32B	Key, 1/4 x 2/14" (See Note 1)	S23677
69A	Washer, Impeller	S06314
69B	Washer, Impeller	S06317
71	Bracket	See Table II
73	O-Ring (See Note 2)	M14943
800A	Capscrew, 3/8 - 16 x 1" (12 Req.)	S26826
800B	Capscrew, 3/8 - 16 x 1-1/8" (8 Req.)	S26827
800C	Capscrew, 1/2 - 13 x 1-1/2" (4 Req.)	S26916
801A	Stud, 3/8 - 16 x 3" (2 Req.)	S04439
801B	Stud, 3/8 - 16 x 4" (2 Req.)	S08303
802	Nut, Hex 3/8 - 16 (2 Req.)	S23343
805A	Washer, Lock	S23036
805B	Washer, Lock	S23038
810	Plug, Pipe 1/4 NPT (5 Req.)	S23715

Table I

B/M No.	HP	PH	RPM	"U" Dim.	Imp. Dia.	Imp. No.
B66487	7.5	1	3600	1-1/4"	7.18"	L06648
B66488	7.5	3	3600	7/8"	7.18"	L06649
B66491	10	1	3600	1-1/4"	7.88"	L06647
B66492	10	3	3600	1-1/4"	7.88"	L06647
B66493	15	3	3600	1-1/4"	8.75"	L06646

Table II

HP	PH	Bracket No.	"AK" Fit	"U" Dim.	Motor Frame
7.5	1	L03827	8-1/2"	1-1/4"	213JP
7.5	3	H00950	4-1/2"	7/8"	184JP
10	1	L03827	8-1/2"	1-1/4"	215JP
10	3	L03827	8-1/2"	1-1/4"	213JP
15	3	L03827	8-1/2"	1-1/4"	215JP

NOTE 1: For an explanation of the tabulated material found on this page and for impeller key location, refer to *Supplement A* located at the beginning of this section.

NOTE 2: Also accepts gasket S05126 as replacement for o-ring. See *Supplement E* located at the beginning of this section.



Type "B" Single Stage Centrifugal Pump Electric Motor Drive

Section	CC
Page	40.5
Date	July 1, 2011
Supersedes 1/1/04	

BRONZE IMPELLER B1-1/2ZPLS

Threaded Case (NPT)

Mechanical Shaft Seal Construction

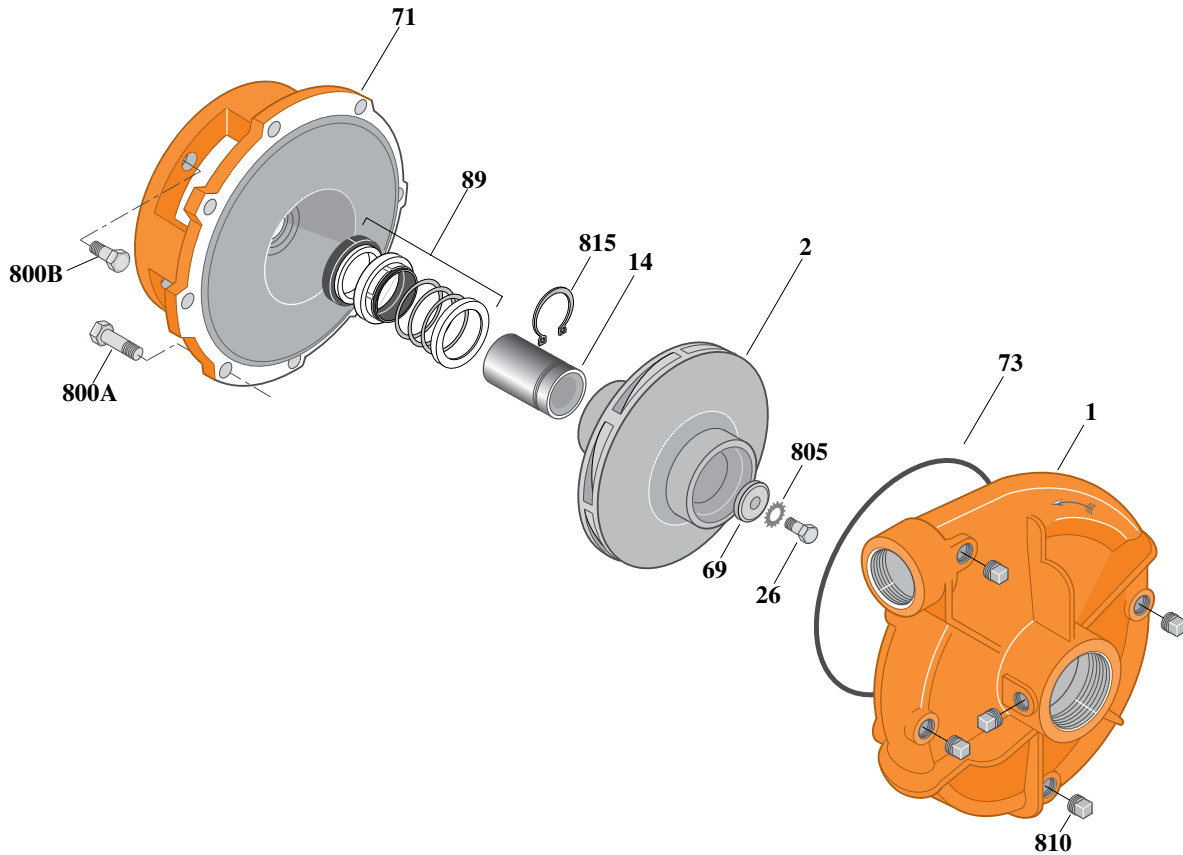

Table I

B/M No.	HP	PH	RPM	"U" Dim.	Imp. Dia.	Imp. No.
B66489	7.5	1	3600	7/8"	7.18"	L06649
B66490	7.5	3	3600	7/8"	7.18"	L06649
B66832	10	1	3600	7/8"	7.88"	L06609
B66833	10	3	3600	7/8"	7.88"	L06609
B66841	15	3	3600	7/8"	8.75"	L06610

Item	Part Description	Part Number
1	Case, Volute	L01025
2	Impeller	See Table I
14	Sleeve, Shaft	S19310L
26	Screw, Impeller 3/8 - 16 x 1"	S23566
32	Key, 3/16 x 1-1/4" (See Note 1)	S34383
69	Washer, Impeller	S06314
71	Bracket	See Table II
73	O-Ring (See Note 2)	M14943
89	Seal, Mechanical Shaft	S32014
800A	Capscrew, 3/8 - 16 x 1" (8 Req.)	S26826
800B	Capscrew, 1/2 - 13 x 1" (4 Req.)	S26912
805	Washer, Lock	S23036
810	Plug, Pipe 1/4 NPT (5 Req.)	S23715
815	Ring, Retaining	S11207

Table II

HP	PH	Bracket No.	"AK" Fit	"U" Dim.	Motor Frame
7.5	1	L05331	8-1/2"	7/8"	213JM
7.5	3	L05332	4-1/2"	7/8"	184JM
10	1	L05331	8-1/2"	7/8"	215JM
10	3	L05331	8-1/2"	7/8"	213JM
15	3	L05331	8-1/2"	7/8"	215JM

NOTE 1: For an explanation of the tabulated material found on this page and for impeller key location, refer to *Supplement A* located at the beginning of this section.

NOTE 2: Also accepts gasket S05126 as replacement for o-ring. See *Supplement E* located at the beginning of this section.



Type "B" Single Stage Centrifugal Pump Electric Motor Drive

Section	CC
Page	40.6
Date	July 1, 2011
Supersedes 1/1/04	

SILICON BRONZE IMPELLER

B1-1/2ZPLS

Threaded Case (NPT)

Mechanical Shaft Seal Construction

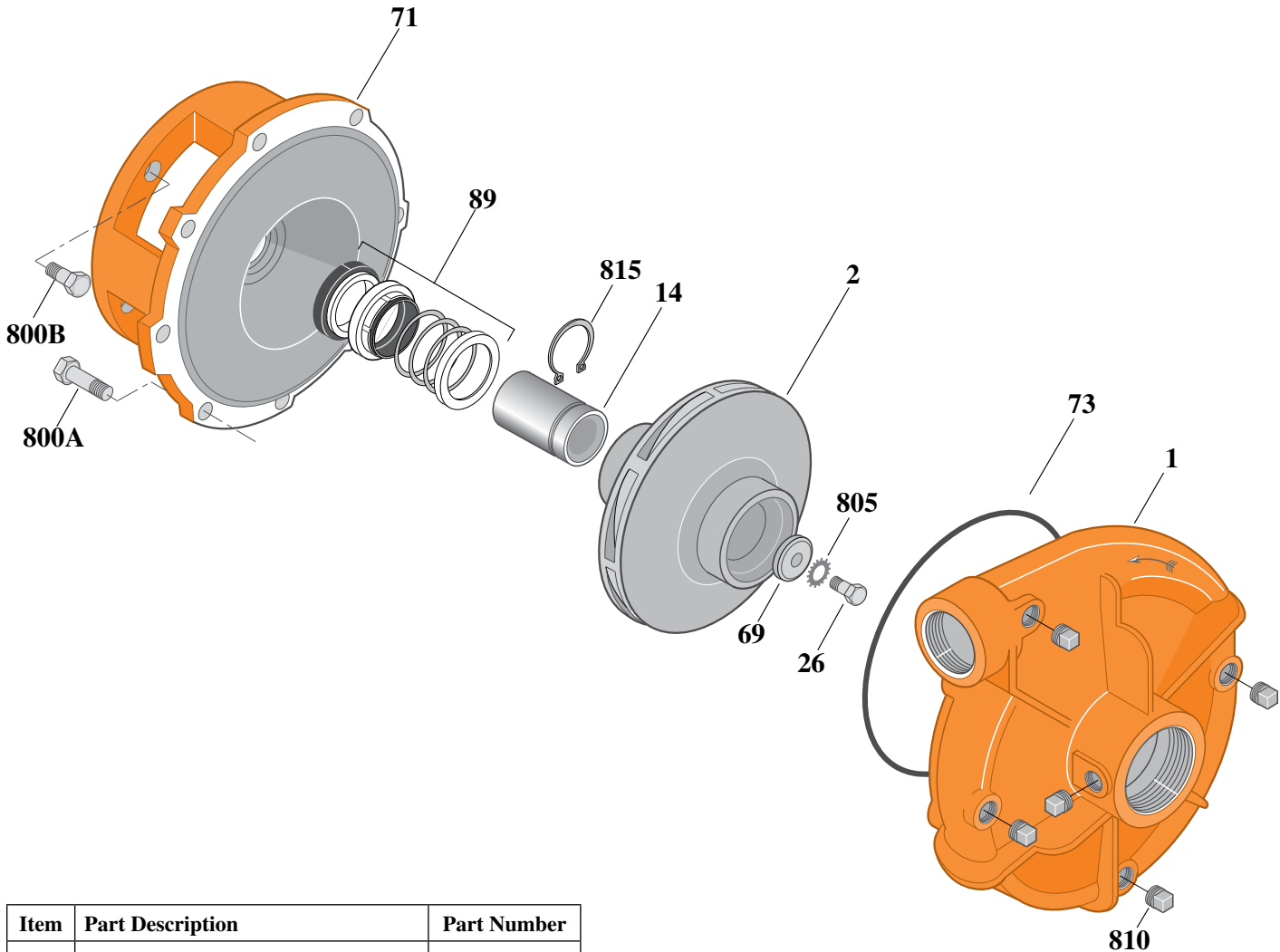

Item	Part Description	Part Number
1	Case, Volute	L03075
2	Impeller	See Table I
14	Sleeve, Shaft	S18869L
26	Screw, Impeller 1/2 - 13 x 1"	S23619
32	Key, 1/4 x 2-1/4" (See Note1)	S23677
69	Washer, Impeller	S06317
71	Bracket	See Table II
73	O-Ring (See Note 2)	M14943
89	Seal, Mechanical Shaft	S32015
800A	Capscrew, 3/8 - 16 x 1-1/8" (8 Req.)	S26827
800B	Capscrew, 1/2 - 13 x 1" (4 Req.)	S26912
805	Washer, Lock	S23038
810	Plug, Pipe 1/4 NPT (5 Req.)	S23715
815	Ring, Retaining	S16767

Table I

B/M No.	HP	PH	RPM	"U" Dim.	Imp. Dia.	Imp. No.
B78660	20	3	3600	1-1/4"	9.00"	H05465

Table II

HP	PH	Bracket No.	"AK" Fit	"U" Dim.	Motor Frame
20	3	L04615	8-1/2"	1-1/4"	254JM

NOTE 1: For an explanation of the tabulated material found on this page and for impeller key location, refer to *Supplement A* located at the beginning of this section.

NOTE 2: Also accepts gasket S05126 as replacement for o-ring. See *Supplement E* located at the beginning of this section.



Type "B" Single Stage Centrifugal Pump Electric Motor Drive

Section	CC
Page	40.7
Date	July 1, 2011
Supersedes 1/1/04	

SILICON BRONZE IMPELLERB1-1/2ZPL

Threaded Case (NPT)

Packing Construction

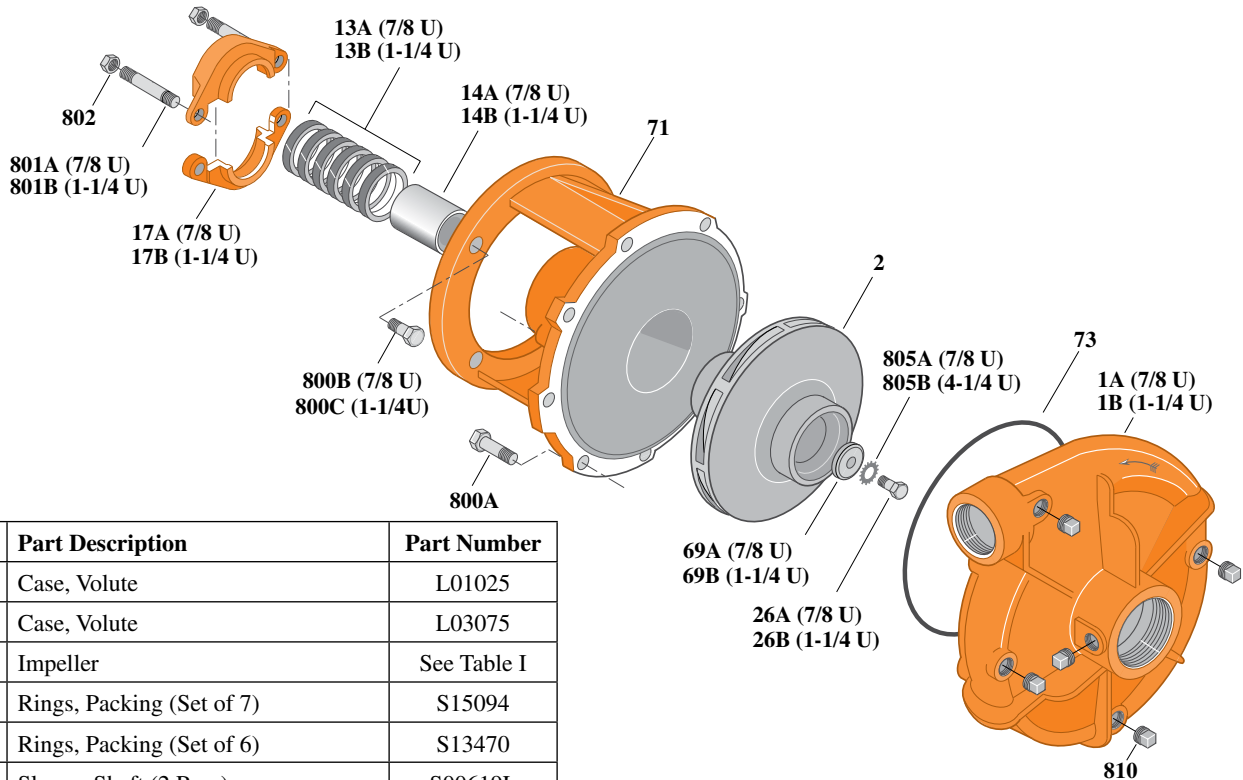

Item	Part Description	Part Number
1A	Case, Volute	L01025
1B	Case, Volute	L03075
2	Impeller	See Table I
13A	Rings, Packing (Set of 7)	S15094
13B	Rings, Packing (Set of 6)	S13470
14A	Sleeve, Shaft (2 Req.)	S00619L
14B	Sleeve, Shaft	S05149L
17A	Gland, Packing	B82469
17B	Gland, Packing	B82470
26A	Screw, Impeller 3/8 - 16 x 1"	S23566
26B	Screw, Impeller 1/2 - 13 x 1"	S23619
32A	Key, 3/16 x 1-1/4" (See Note 1)	S34383
32B	Key, 1/4 x 2/14" (See Note 1)	S23677
69A	Washer, Impeller	S06314
69B	Washer, Impeller	S06317
71	Bracket	See Table II
73	O-Ring (See Note 2)	M14943
800A	Capscrew, 3/8 - 16 x 1" (8 Req.)	S26826
800B	Capscrew, 3/8 - 16 x 1-1/8" (4 Req.)	S26827
800C	Capscrew, 1/2 - 13 x 1-1/2" (4 Req.)	S26916
801A	Stud, 3/8 - 16 x 3" (2 Req.)	S04439
801B	Stud, 3/8 - 16 x 4" (2 Req.)	S08303
802	Nut, Hex 3/8 - 16 (2 Req.)	S23343
805A	Washer, Lock	S23036
805B	Washer, Lock	S23038
810	Plug, Pipe 1/4" NPT (5 Req.)	S23715

Table I

B/M No.	HP	PH	RPM	"U" Dim.	Imp. Dia.	Imp. No.
B66487S	7.5	1	3600	1-1/4"	7.18"	H05458
B66488S	7.5	3	3600	7/8"	7.18"	H05459
B66491S	10	1	3600	1-1/4"	7.88"	H05460
B66492S	10	3	3600	1-1/4"	7.88"	H05460
B66493S	15	3	3600	1-1/4"	8.75"	H05461

Table II

HP	PH	Bracket No.	"AK" Fit	"U" Dim.	Motor Frame
7.5	1	L03827	8-1/2"	1-1/4"	213JP
7.5	3	H00950	4-1/2"	7/8"	184JP
10	1	L03827	8-1/2"	1-1/4"	215JP
10	3	L03827	8-1/2"	1-1/4"	213JP
15	3	L03827	8-1/2"	1-1/4"	215JP

NOTE 1: For an explanation of the tabulated material found on this page and for impeller key location, refer to *Supplement A* located at the beginning of this section.

NOTE 2: Also accepts gasket S05126 as replacement for o-ring. See *Supplement E* located at the beginning of this section.



Type "B" Single Stage Centrifugal Pump Electric Motor Drive

Section	CC
Page	40.8
Date	July 1, 2011
Supersedes 1/1/04	

SILICON BRONZE IMPELLERB1-1/2ZPLS

Threaded Case (NPT)

Mechanical Shaft Seal Construction

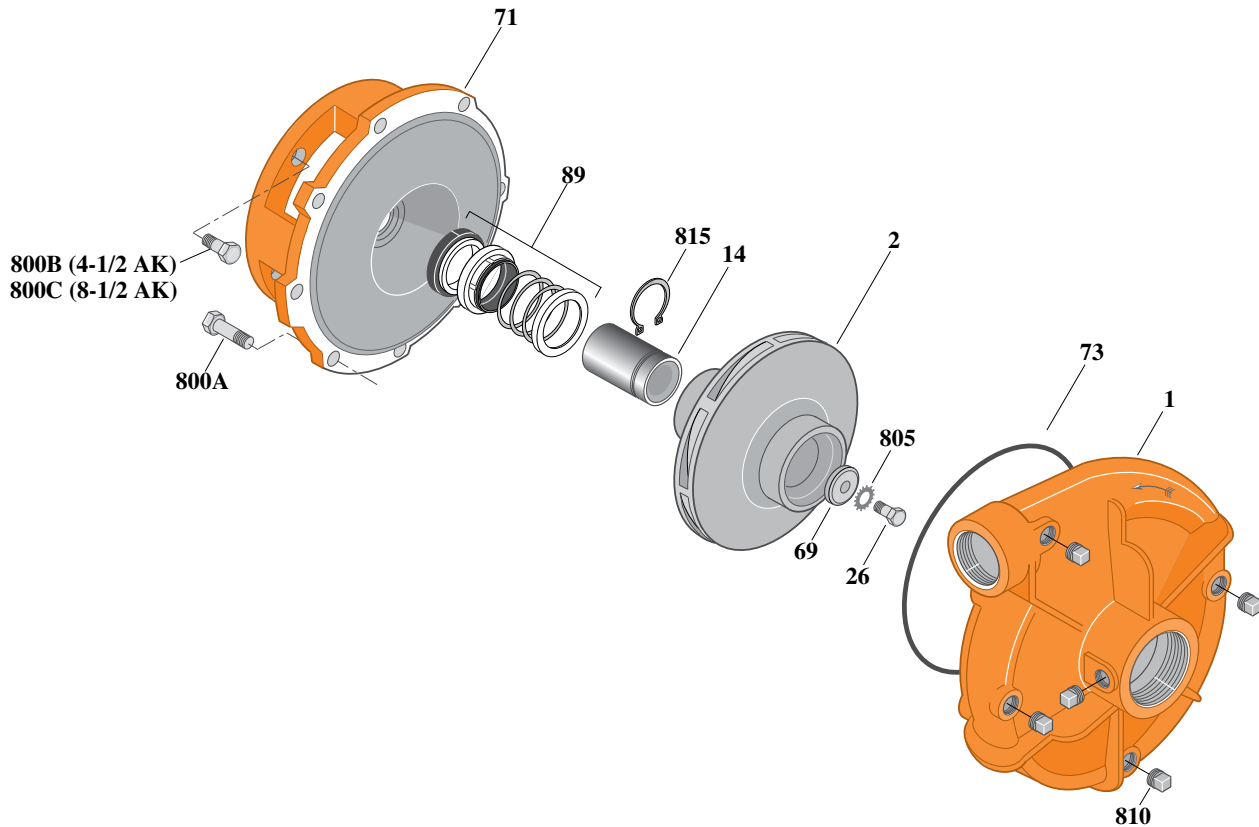

Table I

B/M No.	HP	PH	RPM	"U" Dim.	Imp. Dia.	Imp. No.
B66489S	7.5	1	3600	7/8"	7.18"	H05459
B66490S	7.5	3	3600	7/8"	7.18"	H05459
B66832S	10	1	3600	7/8"	7.88"	H05463
B66833S	10	3	3600	7/8"	7.88"	H05463
B66841S	15	3	3600	7/8"	8.75"	H05464

Table II

HP	PH	Bracket No.	"AK" Fit	"U" Dim.	Motor Frame
7.5	1	L05331	8-1/2"	7/8"	213JM
7.5	3	L05332	4-1/2"	7/8"	184JM
10	1	L05331	8-1/2"	7/8"	215JM
10	3	L05331	8-1/2"	7/8"	213JM
15	3	L05331	8-1/2"	7/8"	215JM

Item	Part Description	Part Number
1	Case, Volute	L01025
2	Impeller	See Table I
14	Sleeve, Shaft	S19310L
26	Screw, Impeller 3/8 - 16 x 1"	S23566
32	Key, 3/16 x 1-1/4" (See Note 1)	S34383
69	Washer, Impeller	S06314
71	Bracket	See Table II
73	O-Ring (See Note 3)	M14943
89	Seal, Mechanical Shaft	S32014
800A	Capscrew, 3/8 - 16 x 1" (8 Req.)	S26826
800B	Capscrew, 3/8 - 16 x 1" (4 Req.)	S26826
800C	Capscrew, 1/2 - 13 x 1" (4 Req.)	S26912
805	Washer, Lock	S23036
810	Plug, Pipe 1/4" NPT (5 Req.)	S23715
815	Ring, Retaining	S11207
•	Plug, Pipe 1/8" NPT (In Bracket)	S23714

NOTE 1: For an explanation of the tabulated material found on this page and for impeller key location, refer to *Supplement A* located at the beginning of this section.

NOTE 2: For seal flush line details, see *Supplement D*.

NOTE 3: Also accepts gasket S05126 as replacement for o-ring. See *Supplement E* located at the beginning of this section.

• Not illustrated.