



Type "B" Single Stage Centrifugal Pump Electric Motor Drive

Section	CC
Page	50.1
Date	July 1, 2011
Supersedes 1/1/04	

CAST IRON IMPELLER

B1-1/2ZPH

Threaded Case (NPT)

Packing Construction

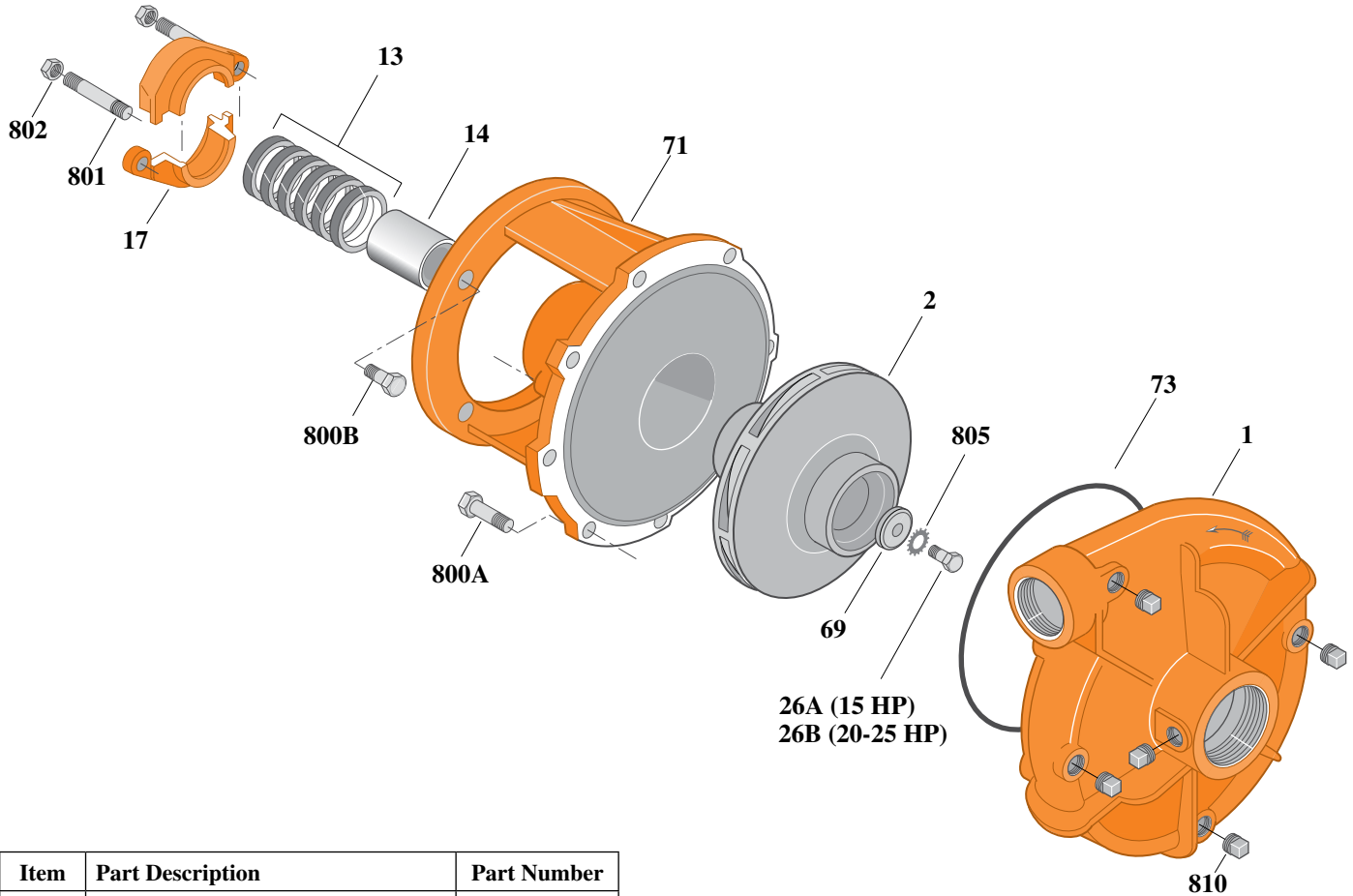

Item	Part Description	Part Number
1	Case, Volute	L03075
2	Impeller	See Table I
13	Rings, Packing (Set of 6)	S13470
14	Sleeve, Shaft	S05149L
17	Gland, Packing	B82470
26A	Screw, Impeller 1/2 - 13 x 1-1/2"	S23623
26B	Screw, Impeller 1/2 - 13 x 1-1/4"	S23621
32	Key, 1/4 x 2-1/4" (See Note 1)	S23677
69	Washer, Impeller	S06319
71	Bracket	See Table II
73	O-Ring (See Note 2)	M14943
800A	Capscrew, 3/8 - 16 x 1-1/8" (8 Req.)	S26827
800B	Capscrew, 1/2 - 13 x 1-1/2" (4 Req.)	S26916
801	Stud, 3/8 - 16 x 4" (2 Req.)	S08303
802	Nut, Hex 3/8 - 16 (2 Req.)	S23343
805	Washer, Lock	S23038
810	Plug, Pipe 1/4 NPT (5 Req.)	S23715

Table I

B/M No.	HP	PH	RPM	"U" Dim.	Imp. Dia.	Imp. No.
B53759	15	3	3600	1-1/4"	7.94"	M07666
B52296	20	3	3600	1-1/4"	8.62"	M07665
B52297	25	3	3600	1-1/4"	9.00"	M04906

Table II

HP	PH	Bracket No.	"AK" Fit	"U" Dim.	Motor Frame
15	3	L03827	8-1/2"	1-1/4"	215JP
20	3	L03827	8-1/2"	1-1/4"	254JP
25	3	L03827	8-1/2"	1-1/4"	256JP

NOTE 1: For an explanation of the tabulated material found on this page and for impeller key location, refer to *Supplement A* located at the beginning of this section.

NOTE 2: Also accepts gasket S05126 as replacement for o-ring. See *Supplement E* located at the beginning of this section.



Type "B" Single Stage Centrifugal Pump Electric Motor Drive

Section	CC
Page	50.2
Date	July 1, 2011
Supersedes 1/1/04	

CAST IRON IMPELLER B1-1/2ZPHS

Threaded Case (NPT)

Mechanical Shaft Seal Construction

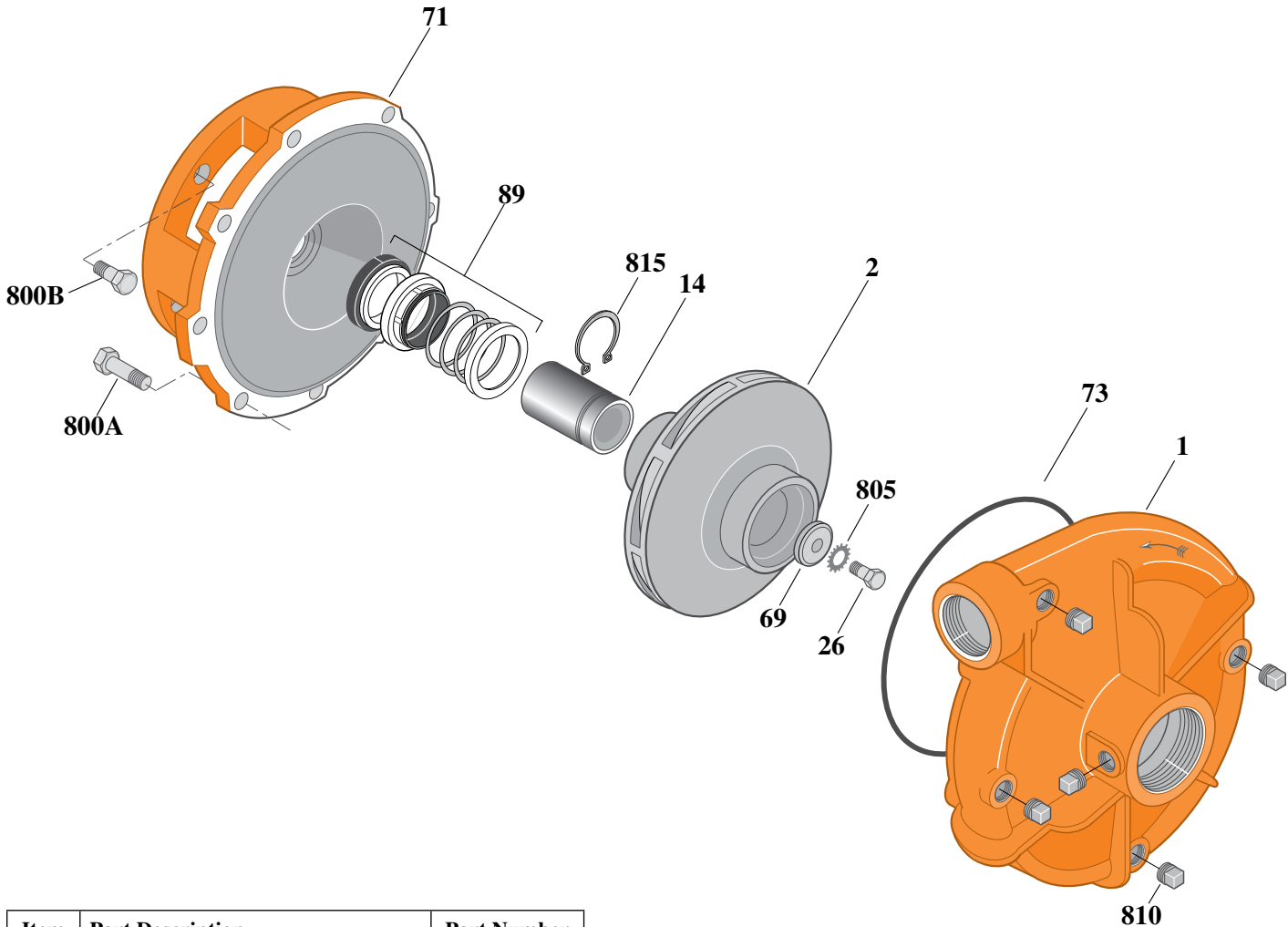

Item	Part Description	Part Number
1	Case, Volute	L03075
2	Impeller	See Table I
14	Sleeve, Shaft	S19310L
26	Screw, Impeller 3/8 - 16 x 1"	S23566
32	Key, 3/16 x 1-1/4" (See Note 1)	S34383
69	Washer, Impeller	S06314
71	Bracket	See Table II
73	O-Ring (See Note 2)	M14943
89	Seal, Mechanical Shaft	S32014
800A	Capscrew, 3/8 - 16 x 1-1/8" (8 Req.)	S26827
800B	Capscrew, 1/2 - 13 x 1" (4 Req.)	S26912
805	Washer, Lock	S23036
810	Plug, Pipe 1/4 NPT (5 Req.)	S23715
815	Ring, Retaining	S11207

Table I

B/M No.	HP	PH	RPM	"U" Dim.	Imp. Dia.	Imp. No.
B54520	15	3	3600	7/8"	7.94"	M07760

Table II

HP	PH	Bracket No.	"AK" Fit	"U" Dim.	Motor Frame
15	3	L05331	8-1/2"	7/8"	215JM

NOTE 1: For an explanation of the tabulated material found on this page and for impeller key location, refer to *Supplement A* located at the beginning of this section.

NOTE 2: Also accepts gasket S05126 as replacement for o-ring. See *Supplement E* located at the beginning of this section.



Type "B" Single Stage Centrifugal Pump Electric Motor Drive

Section	CC
Page	50.3
Date	July 1, 2011
Supersedes 1/1/04	

CAST IRON IMPELLER

B1-1/2ZPHS

Threaded Case (NPT)

Mechanical Shaft Seal Construction

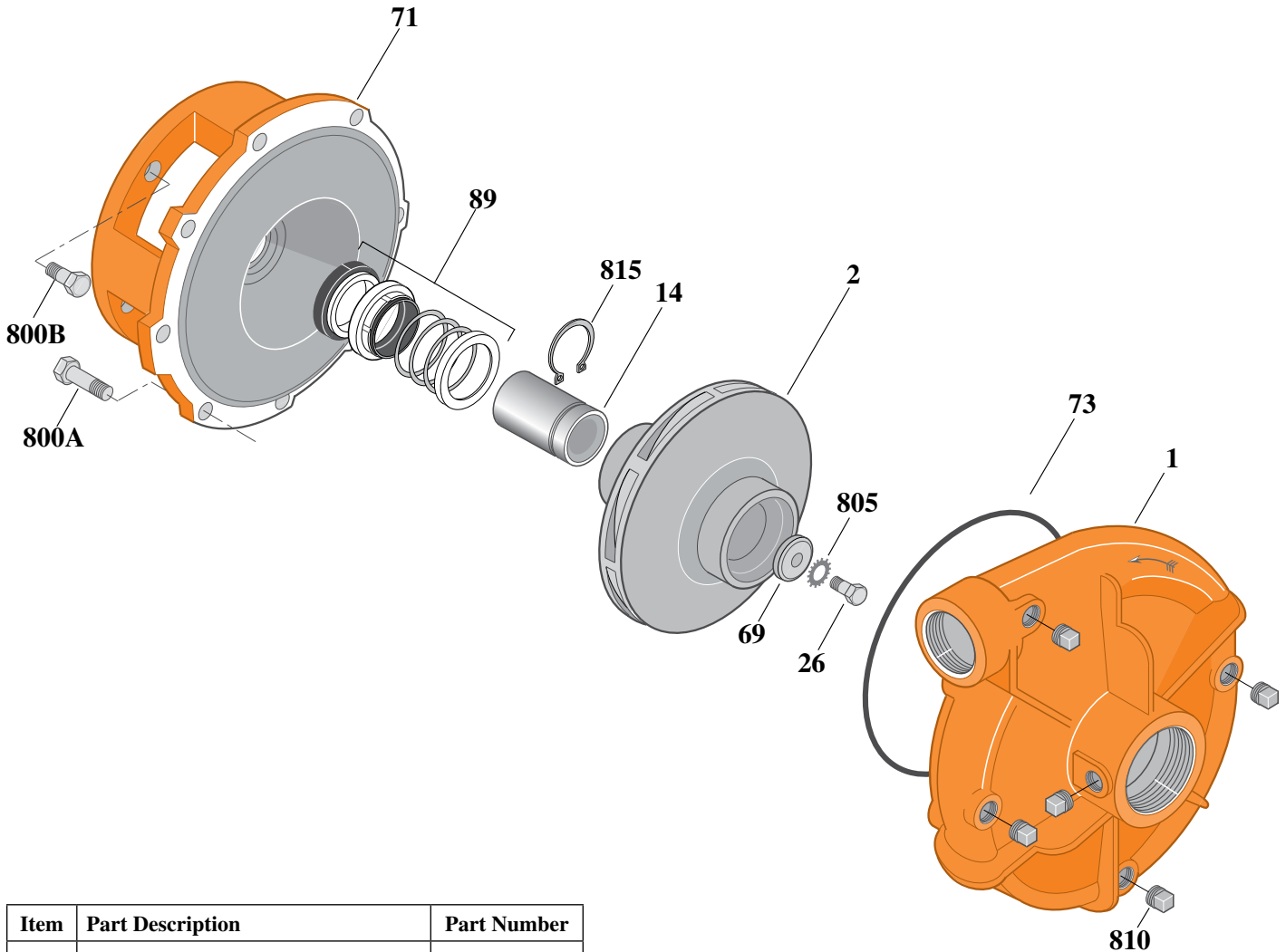

Item	Part Description	Part Number
1	Case, Volute	L03075
2	Impeller	See Table I
14	Sleeve, Shaft	S18869L
26	Screw, Impeller 1/2 - 13 x 1-1/4"	S23621
32	Key, 1/4 x 2-1/4" (See Note 1)	S23677
69	Washer, Impeller	S06319
71	Bracket	See Table II
73	O-Ring (See Note 2)	M14943
89	Seal, Mechanical Shaft	S32015
800A	Capscrew, 3/8 - 16 x 1-1/8" (8 Req.)	S26827
800B	Capscrew, 1/2 - 13 x 1" (4 Req.)	S26912
805	Washer, Lock	S23038
810	Plug, Pipe 1/4 NPT (5 Req.)	S23715
815	Ring, Retaining	S16767

Table I

B/M No.	HP	PH	RPM	"U" Dim.	Imp. Dia.	Imp. No.
B54074	20	3	3600	1-1/4"	8.62"	M07665
B54075	25	3	3600	1-1/4"	9.00"	M04906

Table II

HP	PH	Bracket No.	"AK" Fit	"U" Dim.	Motor Frame
20	3	L04615	8-1/2"	1-1/4"	254JM
25	3	L04615	8-1/2"	1-1/4"	256JM

NOTE 1: For an explanation of the tabulated material found on this page and for impeller key location, refer to *Supplement A* located at the beginning of this section.

NOTE 2: Also accepts gasket S05126 as replacement for o-ring. See *Supplement E* located at the beginning of this section.



Type "B" Single Stage Centrifugal Pump Electric Motor Drive

Section	CC
Page	50.5
Date	July 1, 2011
Supersedes 1/1/04	

SILICON BRONZE IMPELLER

B1-1/2ZPH

Threaded Case (NPT)

Packing Construction

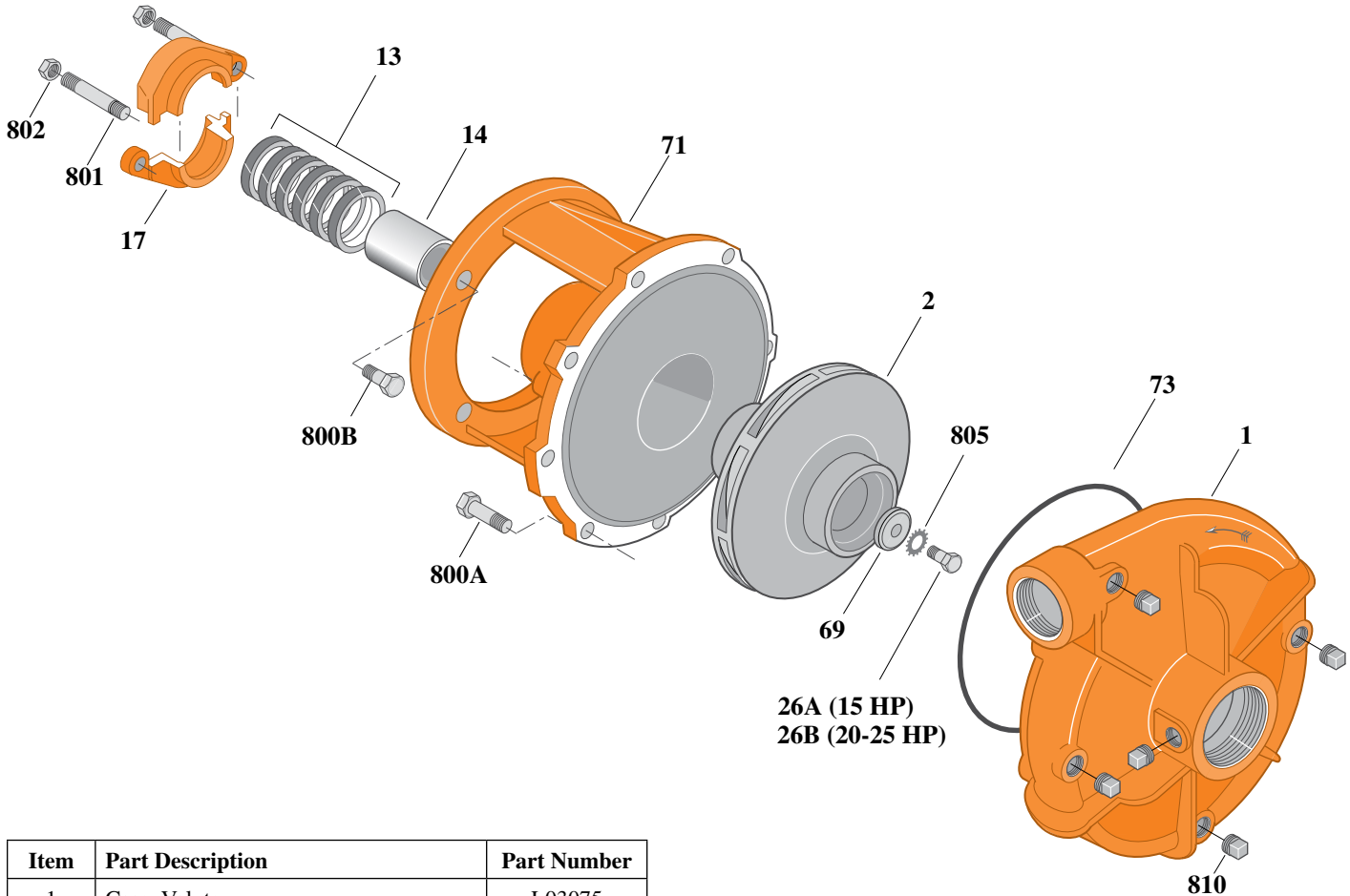

26A (15 HP)
26B (20-25 HP)

Item	Part Description	Part Number
1	Case, Volute	L03075
2	Impeller	See Table I
13	Rings, Packing (Set of 6)	S13470
14	Sleeve, Shaft	S05149L
17	Gland, Packing	B82470
26A	Screw, Impeller 1/2 - 13 x 1-1/2"	S23623
26B	Screw, Impeller 1/2 - 13 x 1-1/4"	S23621
32	Key, 1/4 x 2-1/4" (See Note 1)	S23677
69	Washer, Impeller	S06319
71	Bracket	See Table II
73	O-Ring (See Note 2)	M14943
800A	Capscrew, 3/8 - 16 x 1-1/8" (8 Req.)	S26827
800B	Capscrew, 1/2 - 13 x 1-1/2" (4 Req.)	S26916
801	Stud, 3/8 - 16 x 4" (2 Req.)	S08303
802	Nut, Hex 3/8 - 16 (2 Req.)	S23343
805	Washer, Lock	S23038
810	Plug, Pipe 1/4" NPT (5 Req.)	S23715

Table I

B/M No.	HP	PH	RPM	"U" Dim.	Imp. Dia.	Imp. No.
B74423	15	3	3600	1-1/4"	7.94"	L08156
B74427	20	3	3600	1-1/4"	8.62"	L08155
B74431	25	3	3600	1-1/4"	9.00"	L08153

Table II

HP	PH	Bracket No.	"AK" Fit	"U" Dim.	Motor Frame
15	3	L03827	8-1/2"	1-1/4"	215JP
20	3	L03827	8-1/2"	1-1/4"	254JP
25	3	L03827	8-1/2"	1-1/4"	256JP

NOTE 1: For an explanation of the tabulated material found on this page and for impeller key location, refer to **Supplement A** located at the beginning of this section.

NOTE 2: Also accepts gasket S05126 as replacement for o-ring. See **Supplement E** located at the beginning of this section.



Type "B" Single Stage Centrifugal Pump Electric Motor Drive

Section	CC
Page	50.6
Date	July 1, 2011
Supersedes 1/1/04	

SILICON BRONZE IMPELLER

B1-1/2ZPHS

Threaded Case (NPT)

Mechanical Shaft Seal Construction

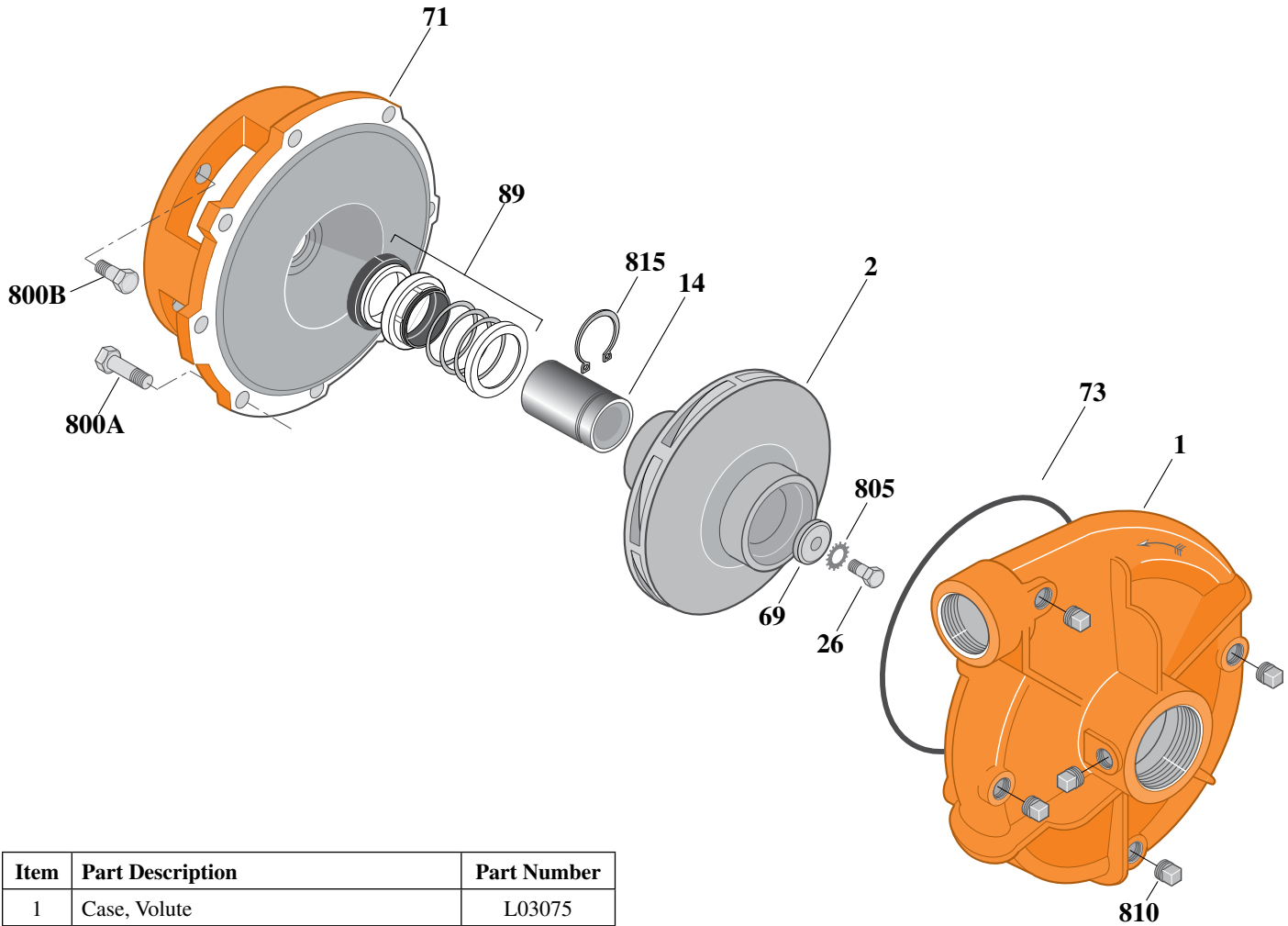

Item	Part Description	Part Number
1	Case, Volute	L03075
2	Impeller	See Table I
14	Sleeve, Shaft	S19310L
26	Screw, Impeller 3/8 - 16 x 1"	S23566
32	Key, 3/16 x 1-1/4" (See Note1)	S34383
69	Washer, Impeller	S06314
71	Bracket	See Table II
73	O-Ring (See Note 3)	M14943
89	Seal, Mechanical Shaft	S32014
800A	Capscrew, 3/8 - 16 x 1-1/8" (8 Req.)	S26827
800B	Capscrew, 3/8 - 16 x 1" (4 Req.)	S26826
805	Washer, Lock	S23036
810	Plug, Pipe 1/4" NPT (5 Req.)	S23715
815	Ring, Retaining	S11207
•	Plug, Pipe 1/8" NPT (In Bracket)	S23714

• Not illustrated.

Table I

B/M No.	HP	PH	RPM	"U" Dim.	Imp. Dia.	Imp. No.
B75254	3	1	1800	7/8"	9.00"	L08374
B75253	3	3	1800	7/8"	9.00"	L08374

Table II

HP	PH	Bracket No.	"AK" Fit	"U" Dim.	Motor Frame
3	1	L05332	4-1/2"	7/8"	184JM
3	3	L05332	4-1/2"	7/8"	182JM

NOTE 1: For an explanation of the tabulated material found on this page and for impeller key location, refer to *Supplement A* located at the beginning of this section.

NOTE 2: For seal flush line details, see *Supplement D*.

NOTE 3: Also accepts gasket S05126 as replacement for o-ring. See *Supplement E* located at the beginning of this section.



Type "B" Single Stage Centrifugal Pump Electric Motor Drive

Section	CC
Page	50.7
Date	July 1, 2011
Supersedes 1/1/04	

SILICON BRONZE IMPELLER

B1-1/2ZPHS

Threaded Case (NPT)

Mechanical Shaft Seal Construction

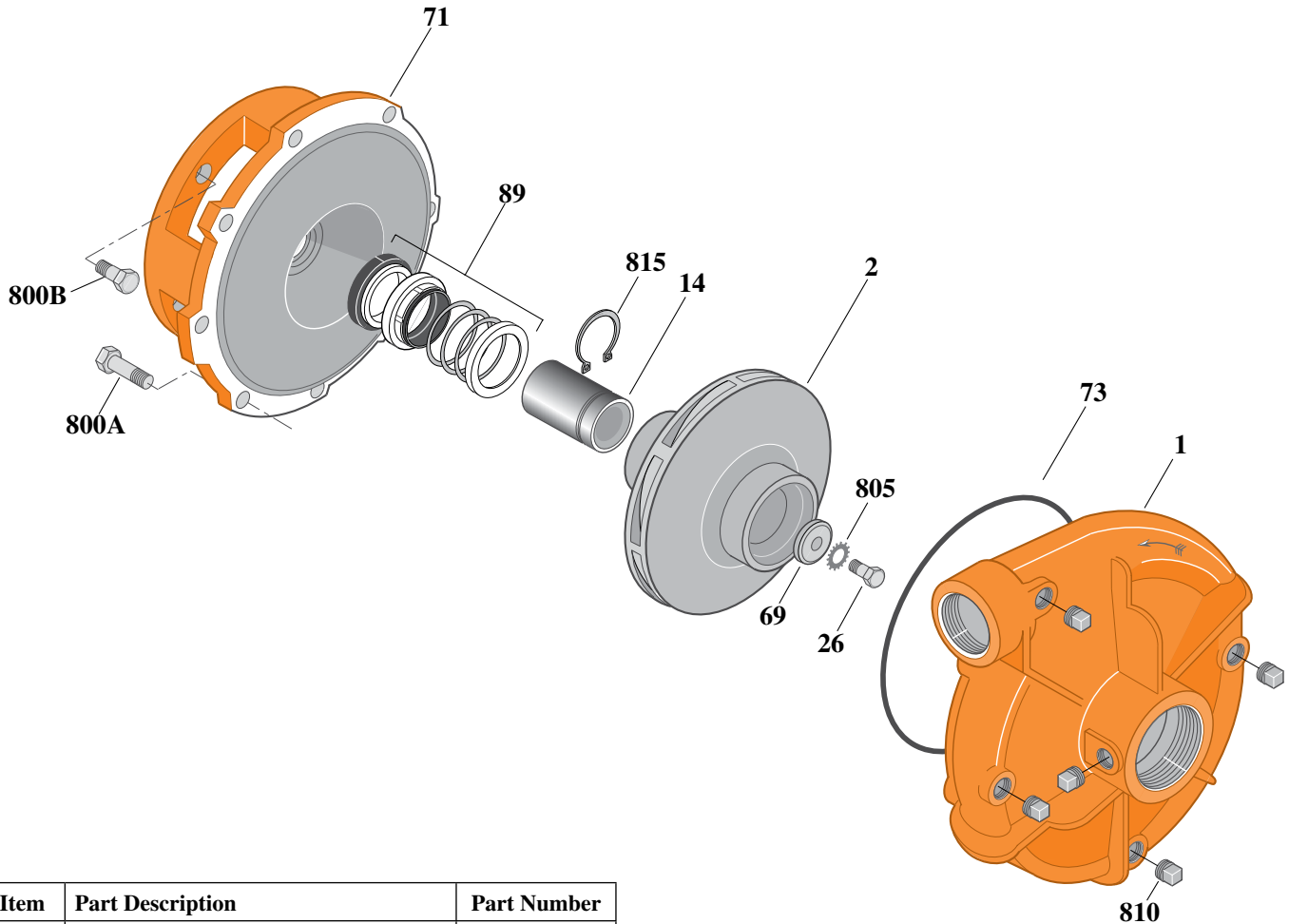

Item	Part Description	Part Number
1	Case, Volute	L03075
2	Impeller	See Table I
14	Sleeve, Shaft	S19310L
26	Screw, Impeller 3/8 - 16 x 1"	S23566
32	Key, 3/16 x 1-1/4" (See Note)	S34383
69	Washer, Impeller	S06314
71	Bracket	See Table II
73	Gasket, Volute	S05126
89	Seal, Mechanical Shaft	S32014
800A	Capscrew, 3/8 - 16 x 1-1/8" (8 Req.)	S26827
800B	Capscrew, 1/2 - 13 x 1" (4 Req.)	S26912
805	Washer, Lock	S23036
810	Plug, Pipe 1/4" NPT (5 Req.)	S23715
815	Ring, Retaining	S11207
•	Plug, Pipe 1/8" NPT (In Bracket)	S23714

• Not illustrated.

Table I

B/M No.	HP	PH	RPM	"U" Dim.	Imp. Dia.	Imp. No.
B74435	15	3	3600	7/8"	7.94"	H05679

Table II

HP	PH	Bracket No.	"AK" Fit	"U" Dim.	Motor Frame
15	3	L05331	8-1/2"	7/8"	215JM

NOTE 1: For an explanation of the tabulated material found on this page and for impeller key location, refer to *Supplement A* located at the beginning of this section.

NOTE 2: For seal flush line details, see *Supplement D*.

NOTE 3: Also accepts gasket S05126 as replacement for o-ring. See *Supplement E* located at the beginning of this section.



Type "B" Single Stage Centrifugal Pump Electric Motor Drive

Section	CC
Page	50.8
Date	July 1, 2011
Supersedes 1/1/04	

SILICON BRONZE IMPELLER B1-1/2ZPHS

Threaded Case (NPT)

Mechanical Shaft Seal Construction

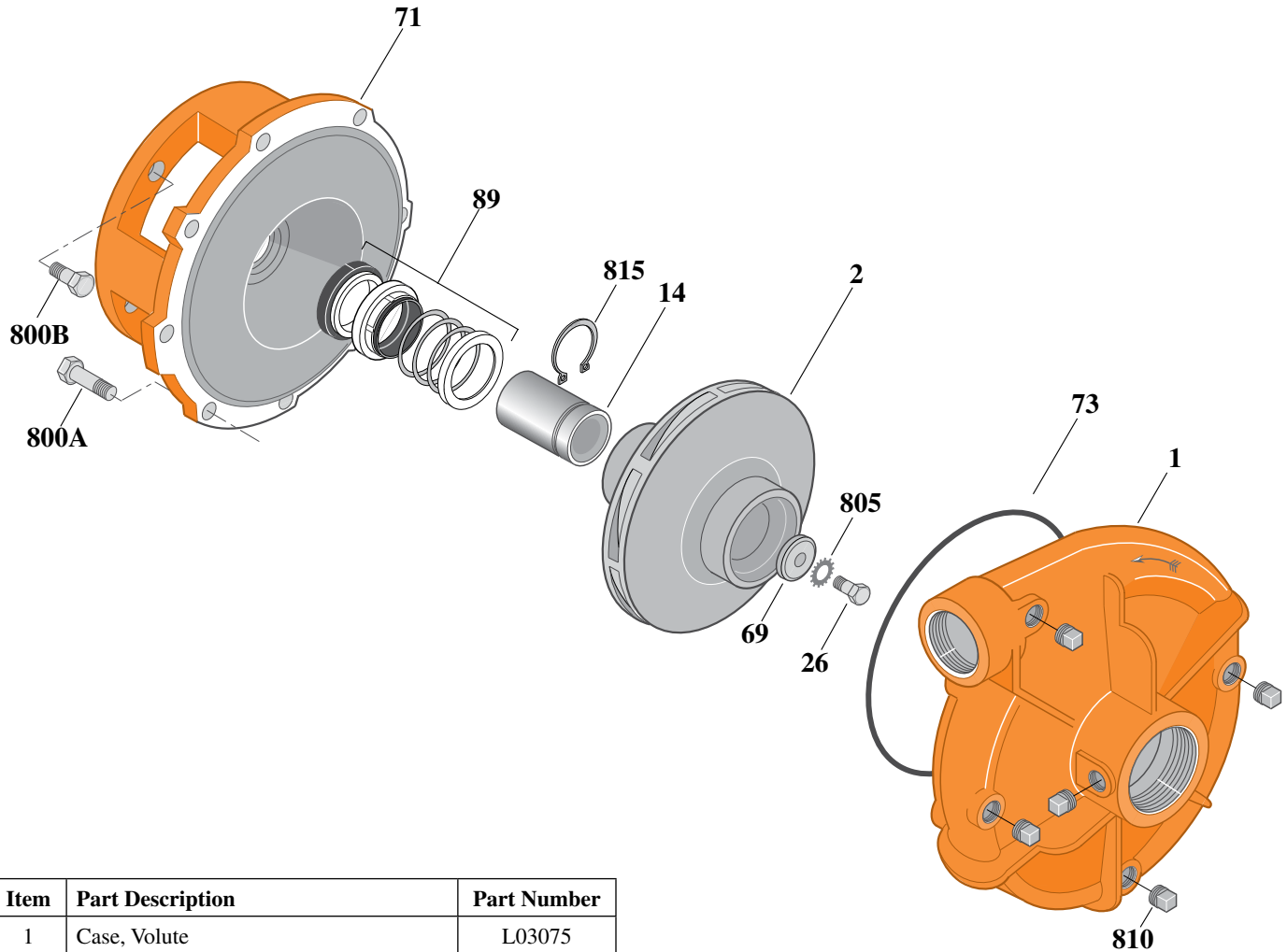

Item	Part Description	Part Number
1	Case, Volute	L03075
2	Impeller	See Table I
14	Sleeve, Shaft	S18869L
26	Screw, Impeller 1/2 - 13 x 1-1/4"	S23621
32	Key, 1/4 x 2-1/4" (See Note 1)	S23677
69	Washer, Impeller	S06319
71	Bracket	See Table II
73	O-Ring (See Note 3)	M14943
89	Seal, Mechanical Shaft	S32015
800A	Capscrew, 3/8 - 16 x 1-1/8" (8 Req.)	S26827
800B	Capscrew, 1/2 - 13 x 1" (4 Req.)	S26912
805	Washer, Lock	S23038
810	Plug, Pipe 1/4" NPT (5 Req.)	S23715
815	Ring, Retaining	S16767
•	Plug, Pipe 1/8" NPT (In Bracket)	S23714

• Not illustrated.

Table I

B/M No.	HP	PH	RPM	"U" Dim.	Imp. Dia.	Imp. No.
B74437	20	3	3600	1-1/4"	8.62"	L08155
B74439	25	3	3600	1-1/4"	9.00"	L08153

Table II

HP	PH	Bracket No.	"AK" Fit	"U" Dim.	Motor Frame
20	3	L04615	8-1/2"	1-1/4"	254JM
25	3	L04615	8-1/2"	1-1/4"	256JM

NOTE 1: For an explanation of the tabulated material found on this page and for impeller key location, refer to *Supplement A* located at the beginning of this section.

NOTE 2: For seal flush line details, see *Supplement D*.

NOTE 3: Also accepts gasket S05126 as replacement for o-ring. See *Supplement E* located at the beginning of this section.