

Manual Steel Filters

Durable, high quality manual steel filters for a wide range of filtration applications

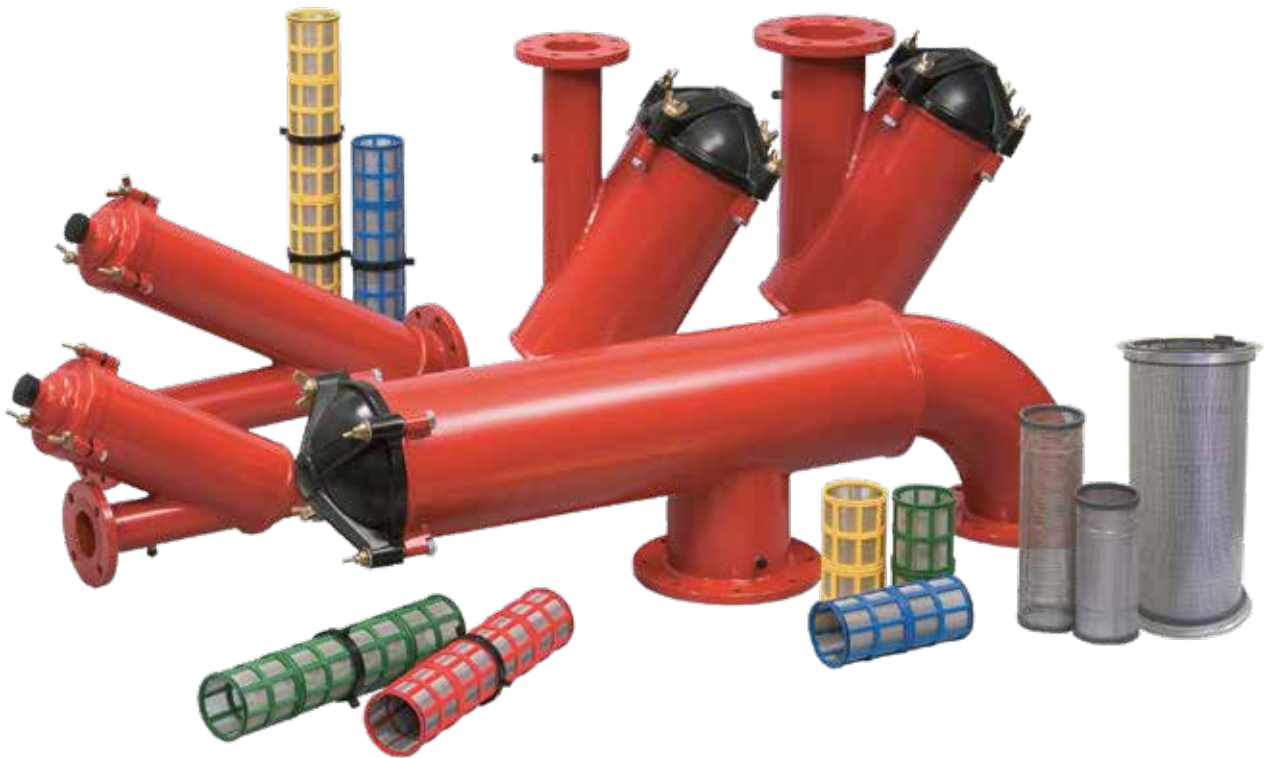

flow rates

up to 300 m³/h
1320 gpm

filtration degrees

3500-80 micron

diameters

50-200 mm
2" - 8"

maximum operating pressure

10 bar
145 psi

features:

- Interchangeable filter elements for a wide range of flow rates, filtration degrees and applications
- High quality polyester coating, as well as stainless steel housings, for chemical durability and corrosion resistance
- Large screen area
- Low pressure loss
- Easy to install and maintain, no tools required to clean screen
- Pressure sensing ports on inlet and outlet

Amiad Manual Steel Filters

General

With their various filter elements, Amiad's all purpose steel filters are made for a wide range of filtering applications and filtration degrees and are easy to install and maintain. They are made of carbon steel with a high quality polyester coating. Stainless steel or rubber - lined housings are also available.

These filters need no special tools for dismantling or extracting the filter element from the filter housing for element cleaning. Visually monitoring the status of the filter element without disrupting the water flow is easily done with Amiad's innovative clogging indicator connected to the filter's upstream and downstream pressure check points upon request. Amiad's manual steel filters can be upgraded to semi-automatic operation by adding one of Amiad's exclusive Brushaway or Scanaway assemblies. Upgrading a manual filter to semi-automatic operation eliminates the need for turning the water off and extracting the filter screen for rinsing. With the semi-automatic assembly, the process flow is not interrupted during operation.

Filter elements

Amiad offers various filter elements for its steel filters in order to cover a wide range of flow rates, multiple filtration degrees, and applications. The direction of water flow in these screen elements is from the inside out along the screen element, therefore the suspended solids accumulate on the inside surface of the screen, while the seals* incorporated into the cylinder ends provide perfect sealing of the element inside the filter housing.

Weavewire stainless steel screen (1)

These screen elements are constructed of molded plastic ribs that support a stainless steel weavewire screen for filtration degrees of 80 to 500 micron.

Perforated stainless steel screen (2)

Suitable for coarse filtration (straining) between 500 and 3500 micron.

* 2"-4" perforated screens do not have seals.

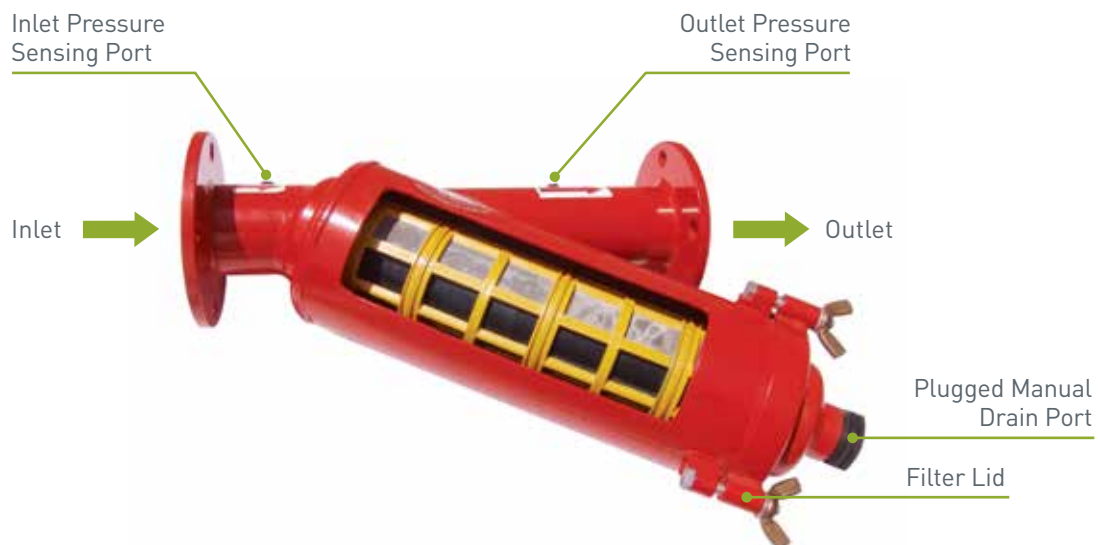
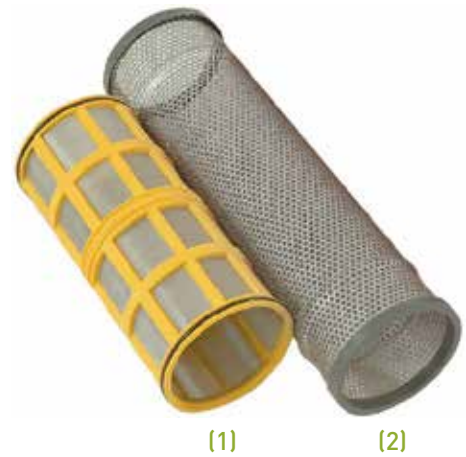

This arrangement allows for:

- Easy removal of the screen element from the filter housing for cleaning
- The accumulation of inorganic suspended solids at the end of the element to be easily removed by means of a flush valve
- Effective separation of inorganic particles
- Low pressure loss
- Manual drain ports
- Optional semi-automatic Brushaway or Scanaway cleaning kits

Filtration degrees available

The following table lists the filtration degrees available for the various Amiad steel filter elements.

For ease of operation and maintenance, the various filtration degrees are color coded.

Please consult your dealer for the most suitable filter element for your application's requirements.

Color	Black	Yellow	Red	White	Blue	Green	Gray			
Micron	80	100	130	200	300	500	800	1500	2500	3500
Mesh	200	155	120	75	50	30	20	10	6	4
2", 3", 4"	▲	▲	▲	▲	▲	★ ▲	★	★	★	★
4" S - 8"	▲	▲	▲	▲	▲	★ ▲	★	★	★	★

▲ Weavewire Screen ★ Perforated Screen

2" In-Line

Dimensional Drawing

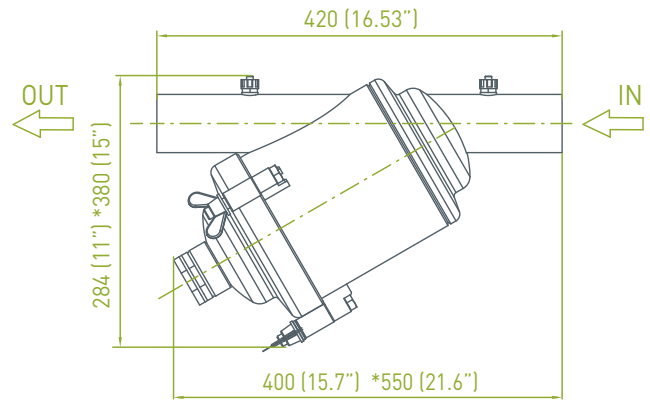

3" In-Line

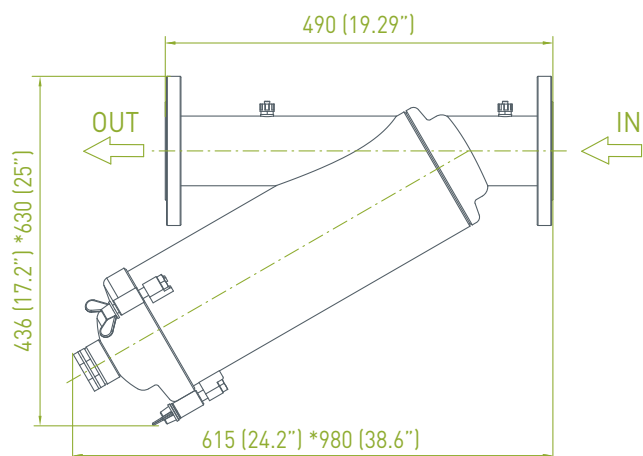

Dim: mm (inch)

*Approx. length required for maintenance

2" In-Line Typical Installation Drawing

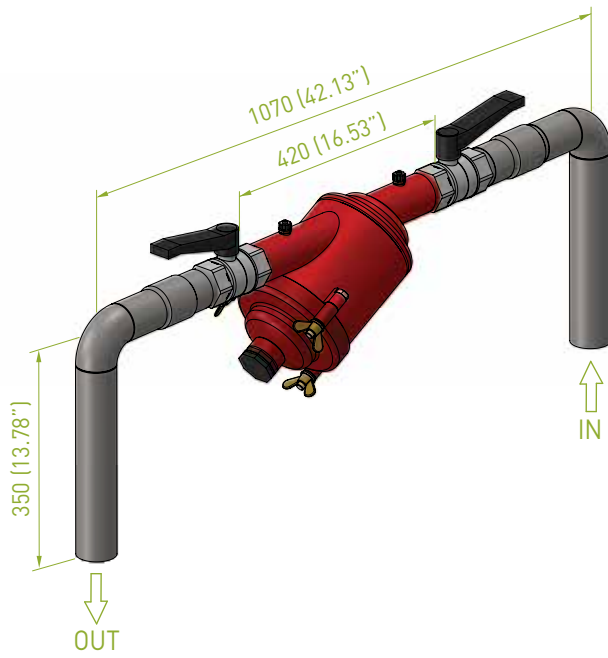

Pressure Loss Graph in clean water

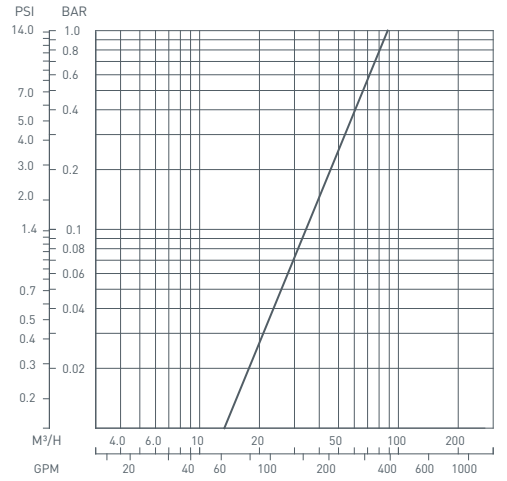

3" In-Line

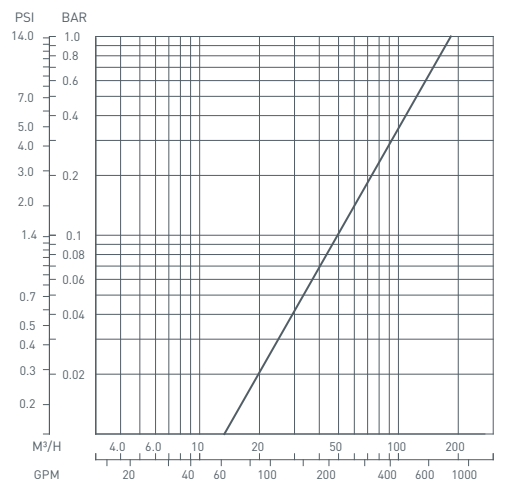
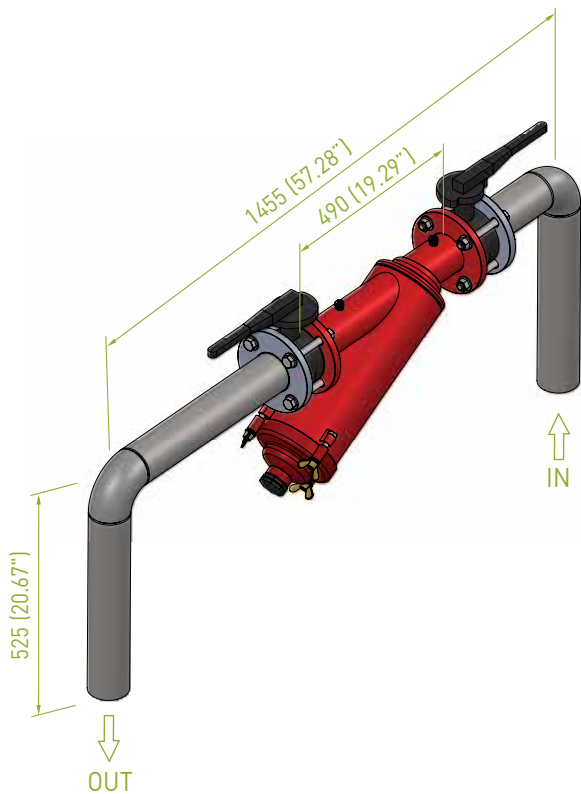

Dim: mm (inch)

4" Compact
In-Line



Dimensional Drawing

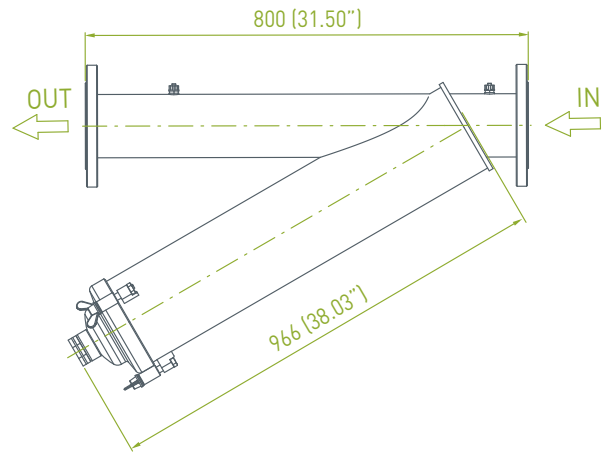

4" Super In-Line/
6" Compact

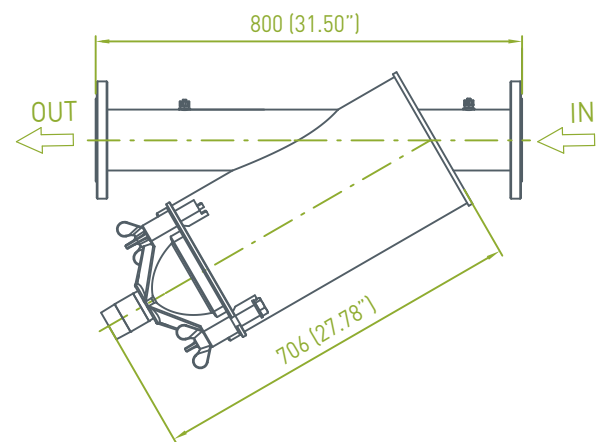

Dim: mm (inch)

*Approx. length required for maintenance

4" Compact In-Line Typical Installation Drawing

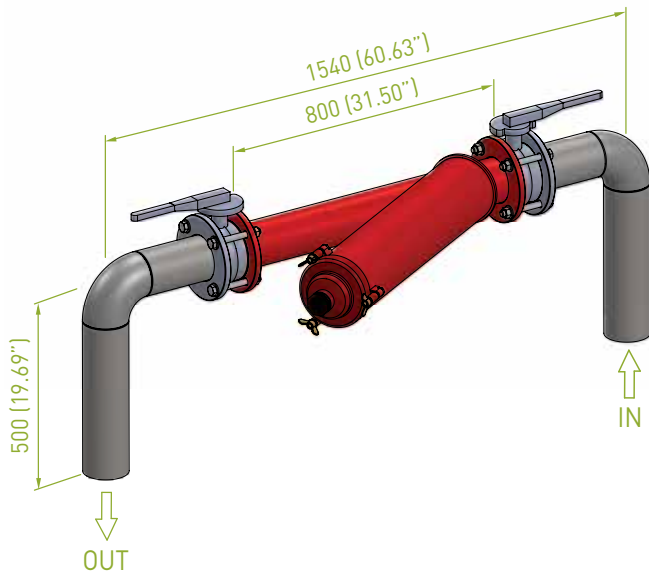

Pressure Loss Graph in clean water

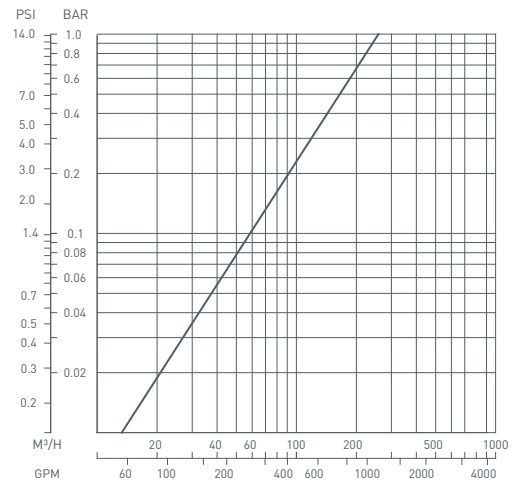

4" Super In-Line/ 6" Compact

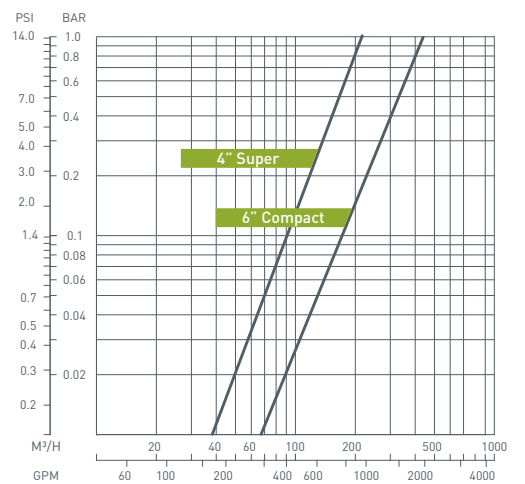
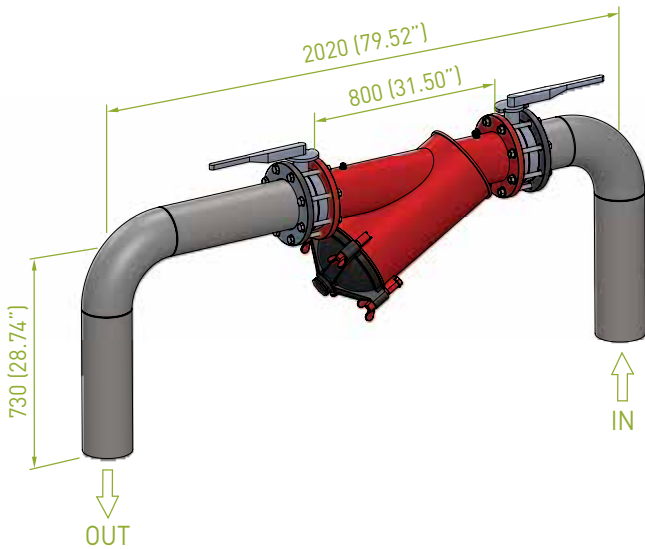

Dim: mm (inch)

6" Super In-Line/
8" In-Line

Dimensional Drawing

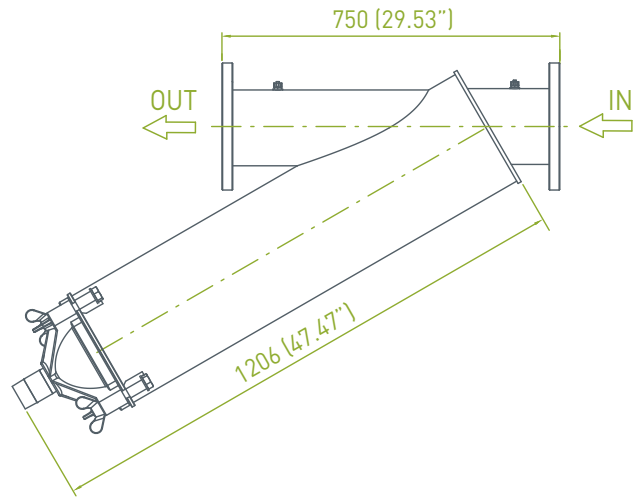

6" Super Modular/
8" Modular

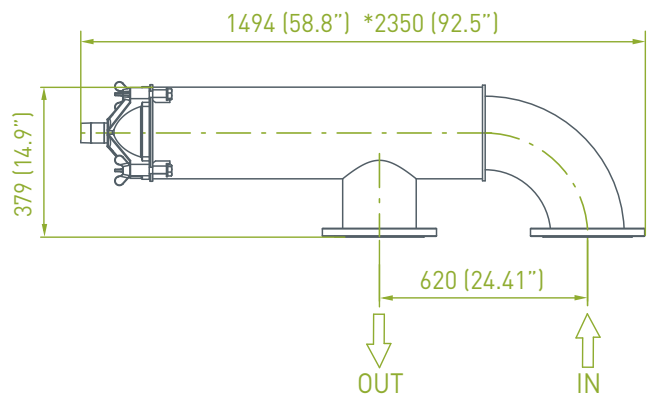

Dim: mm (inch)

*Approx. length required for maintenance

6" Super In-Line/
8" In-Line Typical Installation Drawing

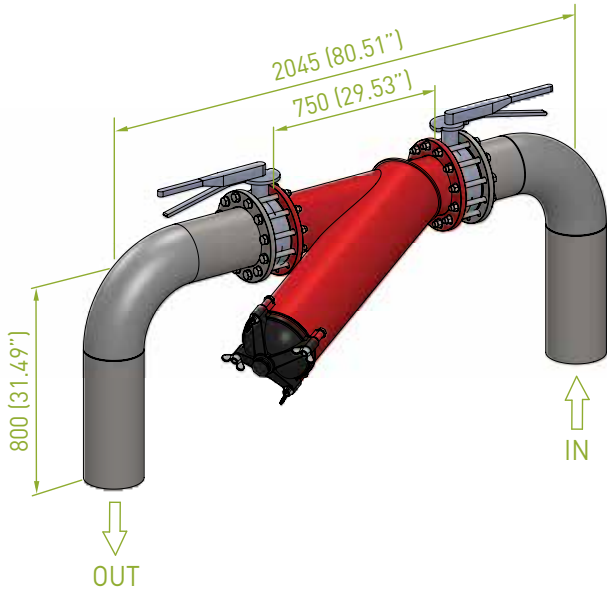

Pressure Loss Graph
in clean water

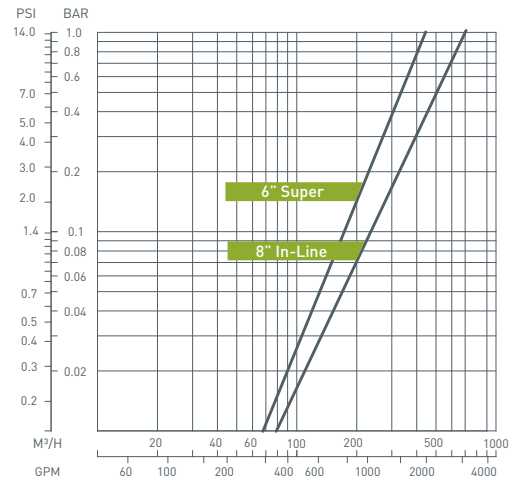

6" Super Modular/
8" Modular

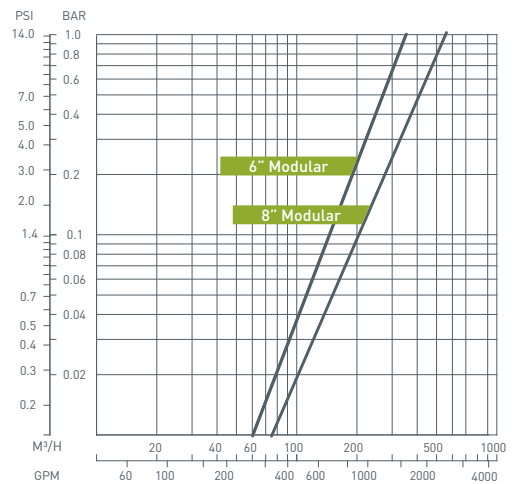
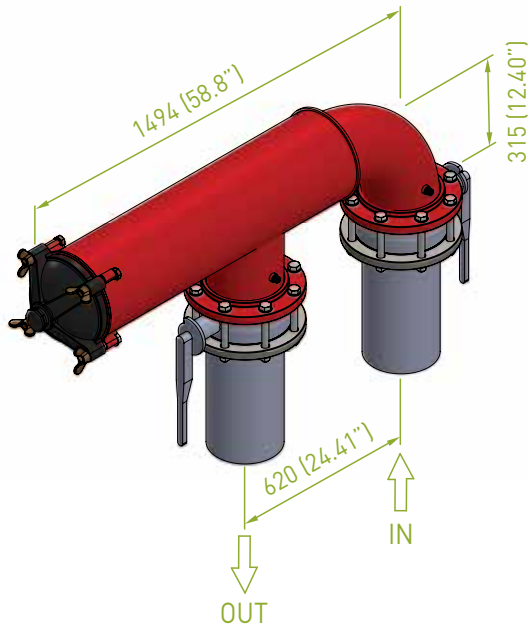

Dim: mm (inch)

Technical Specifications

Filter Type	2" In-Line	3" In-Line
General Data		
Maximum flow rate*	25 m ³ /h (110 gpm)	50 m ³ /h (220 gpm)
Inlet/outlet diameter flanges and threads	50 mm (2")	80 mm (3")
Standard filtration degrees	3500, 2500, 1500, 800, 500, 300, 200, 130, 100, 80 micron	
Max. operating pressure	10 bar (145 psi)	
Max. operating temperature	60°C (140°F)	
Drain port	40 mm (1 1/2") plugged	
Weight [empty] threaded	7.3 kg (16 lbs)	13.6 kg (30 lbs)
Weight [empty] flanged	10.5 kg (23 lbs)	16.6 kg (36.6 lbs)

Filter Type	4" Compact In-Line	4" Super In-Line	6" Compact In-Line
General Data			
Maximum flow rate*	80 m ³ /h (352 gpm)	100 m ³ /h (440 gpm)	160 m ³ /h (704 gpm)
Inlet/outlet diameter	100 mm (4")		150 mm (6")
Standard filtration degrees	3500, 2500, 1500, 800, 500, 300, 200, 130, 100, 80 micron		
Max. operating pressure	10 bar (145 psi)		
Max. operating temperature	60°C (140°F)		
Drain port	40mm (1 1/2") plugged	50 mm (2") unplugged	
Weight [empty] flanges	27.5 kg (60.6 lbs)	38 kg (83.7 lbs)	43 kg (94.7 lbs)

Filter Type	6" Super In-Line/Modular	8" In-Line/Modular
General Data		
Maximum flow rate*	160 m ³ /h (704 gpm)	300 m ³ /h (1,320 gpm)
Inlet/outlet diameter	150 mm (6")	200 mm (8")
Standard filtration degrees	3500, 2500, 1500, 800, 500, 300, 200, 130, 100, 80 micron	
Max. operating pressure	10 bar (145 psi)	
Max. operating temperature	60°C (140°F)	
Drain port	50 mm (2") unplugged	
Weight [empty]	56 kg (123.4 lbs)	65 kg (143.2 lbs)

* Consult Amiad for optimum flow depending on filtration degree and water quality.

Engineering Data

Filter Type	2" In-Line	3" In-Line
-------------	------------	------------

Filter Element Data		
Filtration area	800 cm ² [124 in ²]	1,600 cm ² [248 in ²]
Filter element types	Weavewire screen, perforated screen	

Construction Materials*	
Filter housing	Carbon steel 37-2 with polyester coating
Filter lid	Carbon steel 37-2 with polyester coating
Seals	NBR
Weavewire screen	Polypropylene + glass fibers, stainless steel
Perforated screen	Stainless steel 316

Filter Type	4" Compact In-Line	4" Super In-Line	6" Compact In-Line
-------------	--------------------	------------------	--------------------

Filter Element Data			
Filtration area	2,400 cm ² [372 in ²]	2,800 cm ² [434 in ²]	2,800 cm ² [434 in ²]
Filter element types	Weavewire screen, perforated screen		

Construction Materials*		
Filter housing	Carbon steel 37-2 with polyester coating	SMC polyester
Filter lid	NBR	
Seals	Carbon steel 37-2 with polyester coating	
Weavewire screen	Stainless steel 316 with polypropylene + fiber glass and NBR seals	
Perforated screen	Stainless steel 316 and NBR seals	

Filter Type	6" Super In-Line/Modular	8" In-Line/Modular
-------------	--------------------------	--------------------

Screen Data	
Filtration area	5,800cm ² (899 in ²)
Filter element types	Weavewire screen, perforated screen

Construction Materials*	
Filter housing	Carbon steel 37-2 with polyester coating
Filter lid	SMC polyester
Seals	NBR
Weavewire screen	Stainless steel 316 with polypropylene + fiber glass and NBR seals
Perforated screen	Stainless steel 316 and NBR seals

* Amiad offers a variety of construction materials. Consult us for specifications.

Headquarters

Amiad Water Systems Ltd.

Web: www.amiad.com | E-mail: info@amiad.com

The Americas



USA

Amiad USA Inc.

Web: www.amiadusa.com | E-mail: infousa@amiad.com

Brazil

Amiad Sistemas de Água Ltda.

E-mail: infobrasil@amiad.com

Mexico

Amiad México SA DE CV,

Web: www.amiad.es | E-mail: infomexico@amiad.com

Irrigation office: E-mail: infomexico-irr@amiad.com

Asia



India

Amiad Filtration India Pvt Limited

Web: www.amiadindia.com | E-mail: info-india@amiad.com

China

Amiad China (Yixing Taixing Environtec Co., Ltd.)

Web: www.amiad.com.cn | E-mail: marketing@taixing.cc

South-East Asia

Filtration & Control Systems Pte. Ltd.

E-mail: info-singapore@amiad.com

Australia



Amiad Australia Pty Ltd.

Web: www.amiad.com.au | E-mail: sales@amiad.com

Europe



Amiad Water Systems Europe SAS

E-mail: info@amiad-europe.com

German branch office

E-mail: info@amiad.de

United Kingdom

Amiad Water Systems UK Limited

E-mail: info-uk@amiad.com

[ozglobalb2b.com]



www.amiad.com

910101-000386/03.2019

Copyright © 2013 Amiad Water Systems Ltd. All rights reserved. The contents of this catalogue including without limitation all information and materials, images, illustrations, designs, icons, photographs, graphical presentations, designs, literary works, data, drawings, slogans, phrases, names, trademarks, titles and any other such materials that appear in this catalogue (collectively, the "Contents") are the sole property of Amiad Water Systems Ltd. ("Amiad"). Amiad has sole and exclusive right, title and interest in the Contents, including any intellectual property rights, whether registered or not, and all know-how contained or embodied therein. You may not reproduce, publish, transmit, distribute, display, modify, create derivative works from, sell or participate in any sale of, or exploit in any way, in whole or in part, any of the Contents or the catalogue. Any use of the catalogue or the Contents, other than for personal use, requires the advanced written permission of Amiad.