

Description

Semi-hydraulic three diaphragm pump, for use on sprayers for high pressure pesticide spraying in orchards and vineyards. Suction and delivery manifold separate from pump. Parts in contact with pumped liquids in anodized aluminium, and AISI 303/304. Diaphragms in BlueFlex™. Seals in NBR. Die-cast casing with oil-immersed mechanism and clear plastic tank for visual level checking. Fitted with air-hydraulic damper for smoother operation and less hammer effect in the delivery circuit. Remote level monitoring sensor on request. Remote oil tank installation kit available on request. Oil drainage stopper. Pistons with ring for a more efficient "oil cushion" system to protect the diaphragm.

New-design diaphragm cut-out system to prevent contact tearing even in heavy-duty operating conditions. Spherical sector profile valves for lower flow resistance and improved volumetric efficiency. Mass-produced safety valve and cardan protection. Metal fasteners with galvanised finish.

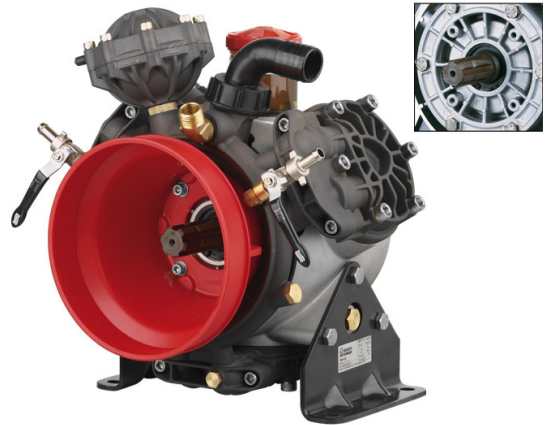

Details	Value
ARCode	32127
Category	BHA
Product	BHA 150
Version	AP C/C
Number of diaph	3
Delivery (l/min)	142,6
Delivery (gpm)	37,7
Pressure (bar)	50
Pressure (psi)	725
Power (hp)	16,3
RPM	550
Weight (kg)	40
Dimensions (mm) L	397
Dimensions (mm) H	417
Dimensions (mm) W	418
Suction (mm)	ø 40
Outlet (mm)	ø 3/4" G(M)
Temperature Max °C	60

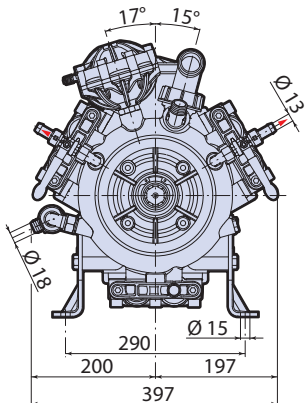
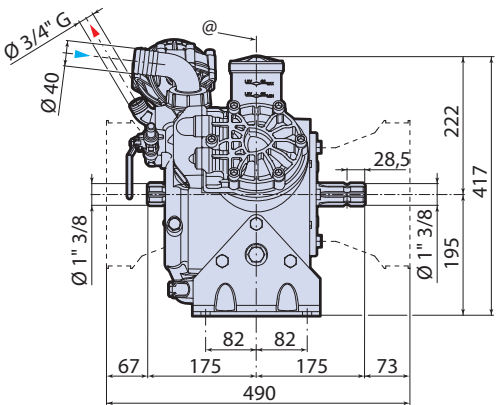

@ = Pump axis - Asse pompa

